

Flow Measurement

SITRANS F US Inline

Inline ultrasonic flowmeters

Overview

Siemens offers two types of ultrasonic flowmeters, inline flowmeters and clamp-on flowmeters. This offers the end user the maximum flexibility to choose the technology that best fits his needs. This chapter shows the inline versions.



SITRANS F US inline ultrasonic flowmeters measure flow of electrically conductive and non-conductive liquids.

Benefits

- Greater flexibility:
 - Sensor sizes from DN 50 to DN 3000 mm (2" to 120")
 - Inline retrofit as 1-path and 2-path up to DN 3000 (120")
 - Compact and remote transmitter installation
 - HART and PROFIBUS PA communication
 - Mains or battery powered solutions
 - Dedicated transmitter portfolio for HVAC, power generation, utility and general industry as well as more demanding applications
- Easier service:
 - Comprehensive self-diagnostic for error indication and logging
 - Exchange of the transducers without interrupting operation
 - Battery lifetime of up to 6 years
- Approvals/certificates:
 - Custody transfer approvals within district heating
 - ATEX
 - Standard with calibration certificate

Application

Inline ultrasonic flowmeters are suitable for measuring the flow of liquids with good acoustic permeability, independent of conductivity, viscosity, temperature, density and pressure.

- max. 3 % solids
- max. 3 % air and gas
- max. 350 cSt

The main applications can be found in the following sectors:

- Raw water intake for water treatment plants
- Treated waste water
- Power generation and utility
- Oil industry and petrochemical industry
- Irrigation systems
- Cooling water plants within the industry and in power stations
- Plants transporting non-conductive liquids
- Custody transfer - district heating (MID-004)
- Cryogenic fluids
- HART/4 to 20 mA output
- PROFIBUS PA
- ATEX

System information SITRANS F US Inline ultrasonic flowmeters

Please see Product selector on the Internet, since some constraints might be related to some of the features:
www.pia-portal.automation.siemens.com



	SONO 3300/ FUS060	SONO 3100/ FUS060	SONOKIT/ FUS060 FUS080	FUE380	FUS380
	7ME3300...	7ME3100...	7ME3210.../ 7ME3220...	7ME3410...	7ME3400...
Industry					
Water, treated waste water	XXX	XX	XXX		XXX
Irrigation	XX	XX	XXX		XXX
Utility, district heating water, cooling	XXX	XX	XXX	XXX	XXX
Utility, district heating, CT approvals required				XXX	
Oil	XX	XXX	XX		X
Cryogenic fluids (only on request)		XXX			
Onshore and Offshore applications	XX	XXX	XX		X
Chemical	XXX	XXX	X		
Design					
Compact transmitter mounted on pipe				●	●
Remote transmitter - Sensor up to 100 m	●	●	●	●	●
Transducers can be replaced under pressure		●	●		
Retrofit on existing steel pipes/non-weldable			●		
Transmitter enclosure					
Polyamid, IP67			●	●	●
Die-cast aluminum (painted), IP65	●	●	●		
Communication					
HART	●	●	●		
PROFIBUS PA	●	●	●		
Power supply					
3.6 V Battery			●	●	●
115 ... 230 V AC	●	●	●	●	●
115 ... 230 V AC and 3.6 V battery backup			●	●	●
24 V AC/DC	●	●	●		
Accuracy					
0.25 % (with 4-path system on request)		●			
0.50 %	●	●	●	●	●
Sensor design					
1-path ultrasonic measurement		●	●		
2-path ultrasonic measurement	●	●	●	●	●
4-path ultrasonic measurement (special request)		● (DN 200 ... 1200)	● (DN 200 ... 1500)		
Dimension					
DN 50	2"	●	U-pipe, on request	Die cast bronze	Die cast bronze
DN 65	2½"	●	U-pipe, on request	Die cast bronze	Die cast bronze
DN 80	3"	●	U-pipe, on request	Die cast bronze	Die cast bronze
DN 100	4"	●	●	1-path only	●
DN 125	5"	●	●	1-path only	●
DN 150	6"	●	●	1-path only	●
DN 200	8"	●	●	●	●
DN 250	10"	●	●	●	●
DN 300	12"	●	●	●	●
DN 350	14"	●	●	●	●
DN 400	16"	●	●	●	●
DN 500	20"	●	●	●	●
DN 600	24"	●	●	●	●
DN 700	28"		On request	●	●
DN 800	32"		On request	●	●
DN 900	36"		On request	●	●
DN 1000	40"		On request	●	●
DN 1200	48"		On request	●	●
DN 1400 ... 2400	54" ... 96"			●	
DN 2500 ... 3000	100" ... 120"			2-path only	
> DN 1200	> 48"			FUS060 only	

X = can be used, XX = often used, XXX = most often used, ● = available

Flow Measurement

SITRANS F US Inline

System information SITRANS F US Inline ultrasonic flowmeters

Please see Product selector on the Internet, since some constraints might be related to some of the features:
www.pia-portal.automation.siemens.com



	SONO 3300/ FUS060	SONO 3100/ FUS060	SONOKIT/ FUS060 FUS080	FUE380	FUS380
	7ME3300...	7ME3100...	7ME3210.../ 7ME3220...	7ME3410...	7ME3400...
Process connection					
Flanges	●	●		●	●
Flangeless (for weld-in)		●			
Flanges Norm					
EN 1092-1	●	●		●	●
EN 1759-1	●	●			
ANSI B16.5		●			
Pressure rating					
PN 6			●		
PN 10	●	●	●		
PN 16	●	●	●	●	●
PN 25		●	●	●	●
PN 40	●	●	●	●	●
Class 150	●	●			
Class 300	●	●			
Pipe, flange					
Carbon steel	●	●	●	●	●
Die cast bronze (DN 50, 65, 80)				●	●
Media temperature					
°C	°F				
-20		-4	●		
-10	●	+14	●		
+2	●	+35.6	●	Min. 5 °C (41 °F)	●
+60	●	+140	●	●	●
+120	●	+248	●	Compact	Compact
+150	●	+302	●	Die cast bronze	Die cast bronze
+160	●	+320	●	●	●
+190		+374	●	●	●
+200		+392	●	●	●
-200 ... +100		-328 ... +212	Cryogenic		
Measuring principle					
Transit time principle	●	●	●	●	●
Approvals					
<u>Custody transfer approval</u>					
MID, MI-004, EN 1434 (European energy meter standard)				●	
Other country-specific type approval available for:					
● Russia	●	●	●	●	●
● China (CPA/CMC)				●	
● Korea KC	●	●	●	●	●
<u>Ex approval</u>					
Ex d ATEX		●	●		
Ex i ATEX	●	●	●		

● = available

Function

Physical principle (single path)

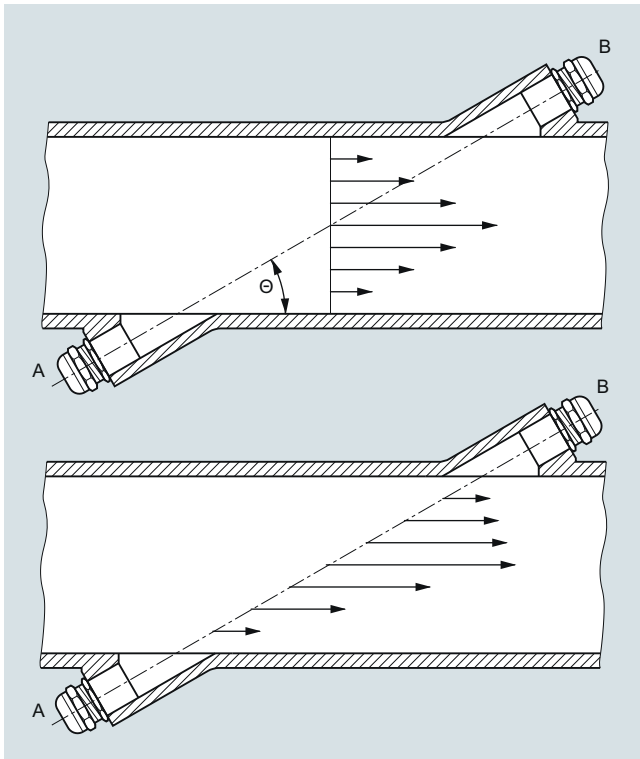

Velocity distribution along sound path

A sound wave traveling in the same direction as the liquid flow arrives at point B from point A in a shorter time than the sound wave traveling against the direction of flow (from point B to A). The difference in sound transit time indicates the flow velocity in the pipe.

Since delay time is measured at short intervals both in and against flow direction, viscosity and temperature have no influence on measurement accuracy.

Measuring principle

In SITRANS F US flowmeters the two ultrasonic transducers are placed at an angle θ in relation to the pipe axis. The transducers function as transmitters and receivers of the ultrasonic signals. Measurement is performed by determining the time the ultrasonic signal takes to travel with and against the flow. The principle can be expressed as follows:

$$v = K \cdot (t_{B,A} - t_{A,B}) / (t_{A,B} \cdot t_{B,A}) = K \cdot \Delta t / t^2$$

v = Average flow velocity

t = Transit time

K = Proportional pipe geometry factor

This measuring principle offers the advantage that it is independent of variations in the actual sound velocity of the liquid, i.e. independent of the temperature.

Proportional factor K is determined by wet calibration.

Direct signal processing

The ultrasonic signal is sent directly between the transducers. The advantage gained sending signals from point to point is an extremely good signal strength.

2-path solution

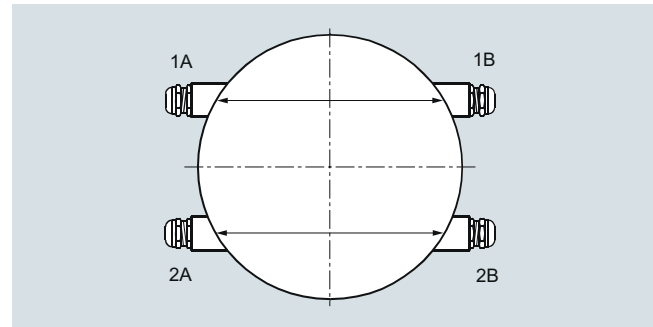

Ultrasonic 2-path flowmeter with 4 transducers. In the upper path transducers 1A / 1B and in the lower path 2A / 2B are displayed.

The accuracy of ultrasonic flowmeters depends on the pipe geometry before and after the flowmeter and the number of ultrasonic measuring paths.

When water flows through a pipe, it has a tendency to swirl and/or flow with different velocities inside the pipe, depending on the pipe design.

A 2-path ultrasonic flowmeter offers:

- less sensitivity to upstream obstruction like bends, pumps or valves.
- high security in the measurements as the meter continues to measure even if, for some reason, one path stops working.

Typical straight inlet requirements are upstream $10 \times D_i$ (D_i = diameter of the flowmeter) and downstream $3 \times D_i$.

Typical accuracy that can be reached with 2-path ultrasonic flowmetering is $\pm 0.5\%$ with installations according to above demands.

4-path ultrasonic flowmeters

Some applications require accuracy under extreme short inlet conditions and swirl that cannot be obtained with 2-path solutions.

For these applications we can offer a 4-path solution – customer-specified – according to actual inlet conditions.

Please contact Siemens Flow Instruments for specific applications.

Flow Measurement

SITRANS F US Inline

System information SITRANS F US Inline ultrasonic flowmeters

Technical specifications

3

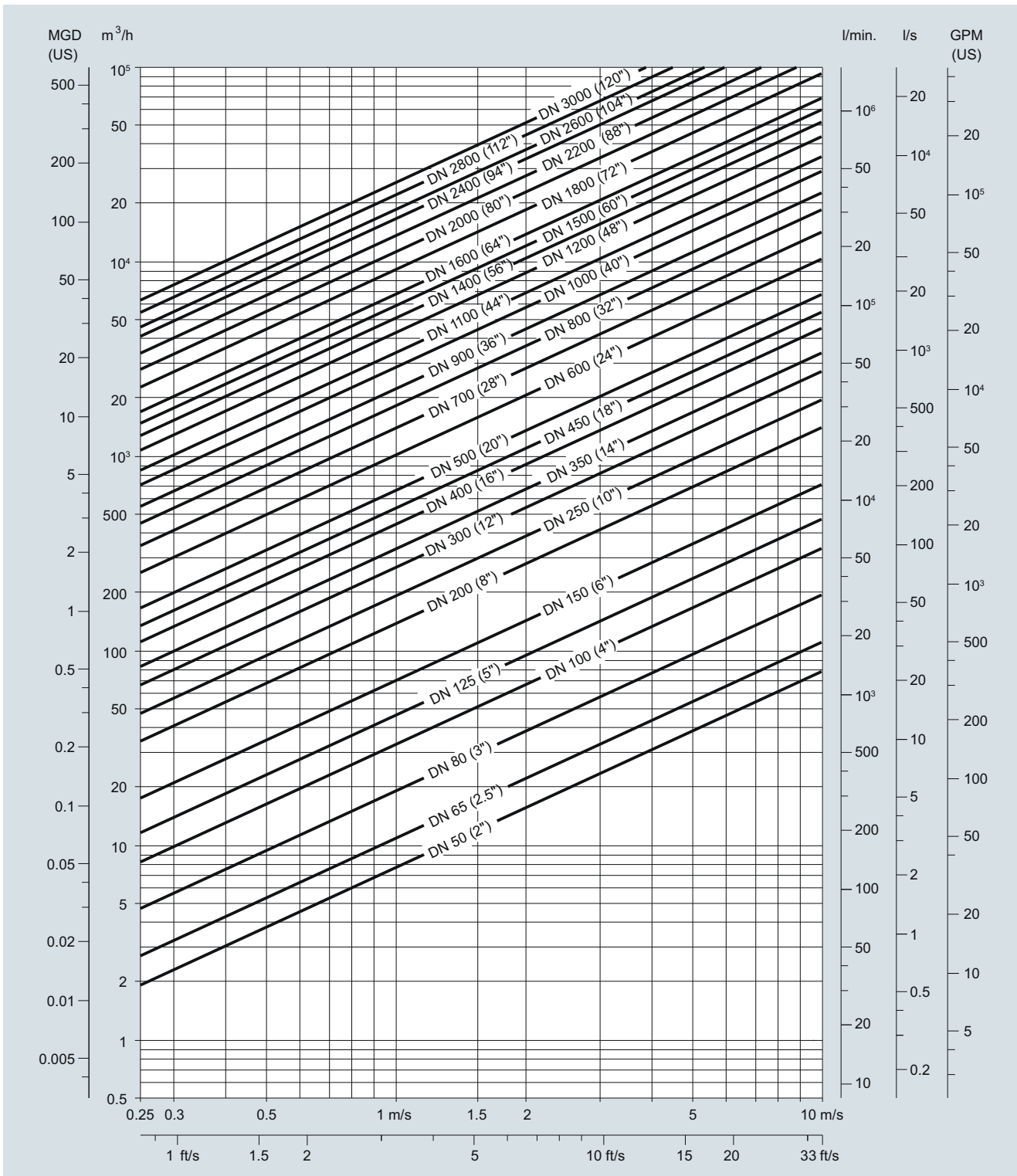

Nominal size and flow

Guidelines for selection of sensor

- Min. measuring range: 0 ... 1 m/s
- Max. measuring range: 0 ... 10 m/s

Nominal flow velocity:

- Normal: 1 ... 3 m/s
- Minimum: not permanently below 0.5 m/s
- Maximum: up to 8 m/s

Flow velocity calculation formula:

- $v = (4 \times Q_{\max}) / (\pi \times D_i^2 \times 3600)$
- v in m/s, Q_{\max} in m³/h, D_i in m

Additional to the flow velocity check it is recommended to observe the Reynolds number (Re):

The optimal performance of the flowmeter is with a Re above 10 000, which is typical for flow velocities (water) above 0.5 m/s. Avoid an Re value between 2000 and 5000. In order to observe this and to be above the recommended 0.5 m/s flow velocity limit the sensor size must be reduced.

Re formula: $Re = V \times D_i / \text{Viscosity}$

V in m/s, D_i in m, Viscosity in cSt ($X \times E^{-6} \text{ m}^2/\text{s}$)

Example: Viscosity for water at 20 °C = $1 \times E^{-6} \text{ m}^2/\text{s}$

Inlet and outlet conditions

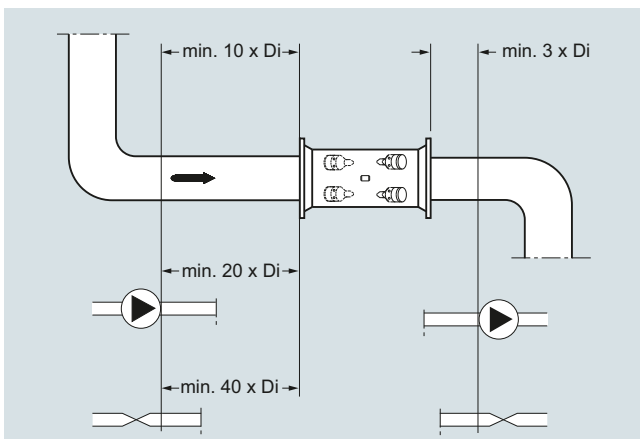

Recommended inlets and outlets

To maximize performance inlet and outlet must be straight. There must be a certain distance between flowmeter and bends, pumps and valves. It is also important to centre the flowmeter in relation to pipe flanges and gaskets.

Valves must always be installed after the flowmeter. The only exception is installation of the sensor in a vertical pipe. In this case a valve below the sensor is necessary to allow zero point adjustment. It is important to select a valve which does not alter the flow when fully open.

Recommended inlet/outlet	SONO 3300, SONO 3100, SONOKIT 2-path		
	SONO 3300, SONO 3100, SONOKIT 2-path	FUS380/FUE380 ¹⁾	SONOKIT 1-path
90° bend	10 x D _i	10 x D _i	20 x D _i
Fully opened valve	10 x D _i	10 x D _i	20 x D _i
Partially opened valve	40 x D _i	40 x D _i	40 x D _i
2 x 90° bends in same plane	15 x D _i	15 x D _i	25 x D _i
2 x 90° bends in two planes	20 x D _i	20 x D _i	40 x D _i
Reductions (Outlet 0 x D _i)	10 x D _i	10 x D _i	20 x D _i
Pumps	20 x D _i	20 x D _i	40 x D _i
Outlet	3 x D _i	3 x D _i	3 x D _i

¹⁾ Inlet for FUE380 approved systems: Minimum straight inlet pipe: 1.5 m, but note further recommendations above.

Reductions

The flowmeter can be installed between two reducers (e.g. DIN 28545). At 8° the pressure drop curve below applies.

Example:

A flow velocity of 3 m/s (V) in a sensor with a diameter reduction from DN 250 to DN 200 ($d_1/d_2 = 0.8$) gives a pressure drop of 3 mbar.

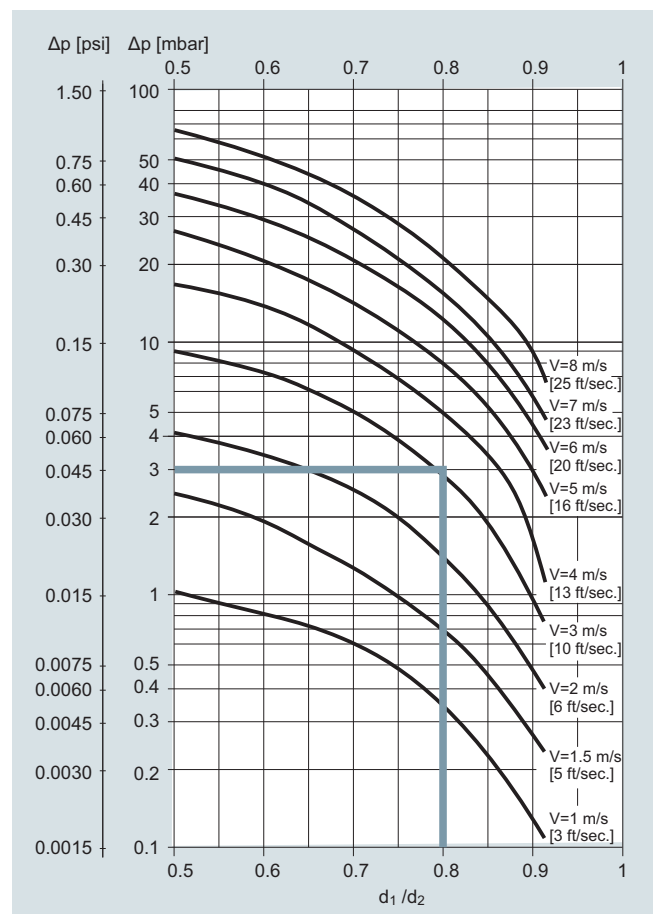
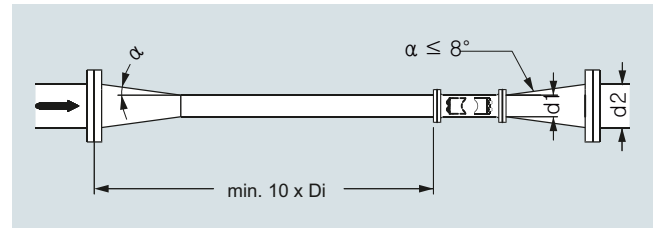

The sensor must always be completely filled with liquid:

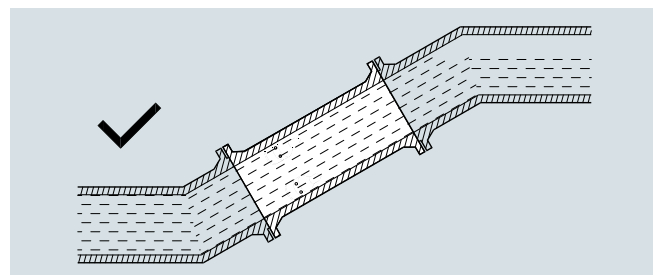

The following installations must be avoided:

- Installation at the highest point of the pipe system
- Installation in vertical pipes with free outlet

Flow Measurement

SITRANS F US InLine

System information SITRANS F US InLine ultrasonic flowmeters

3

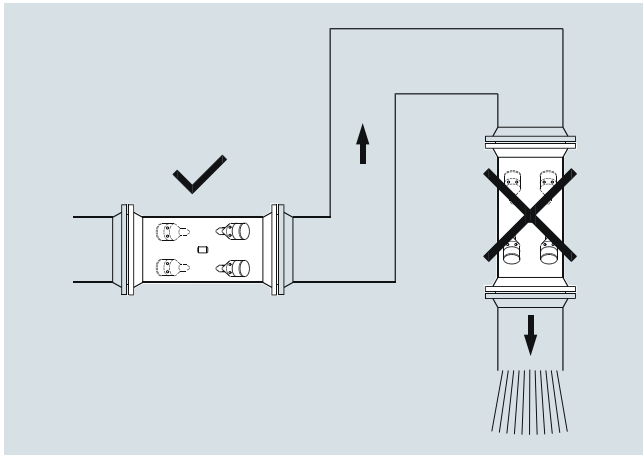
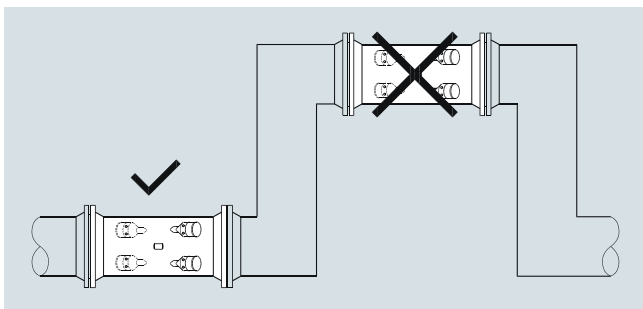

With partially full pipes or pipes with free outlet the flowmeter should be located in a U-shaped tube:

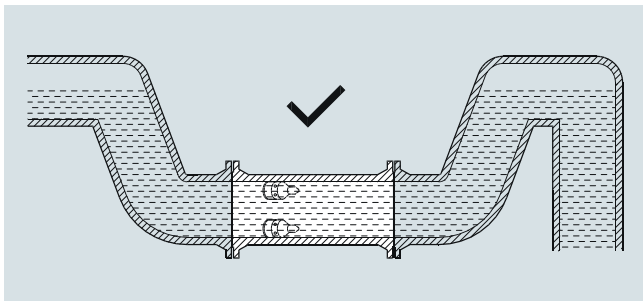

Installing the transducers in horizontal position is recommended:

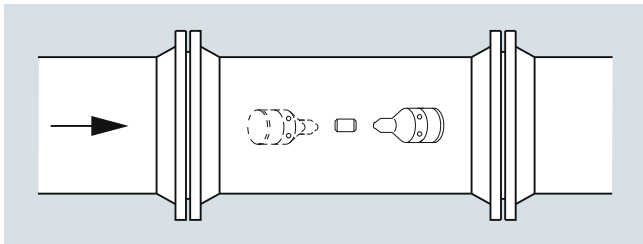

Pressure/temperature curve to EN (DIN) flanges

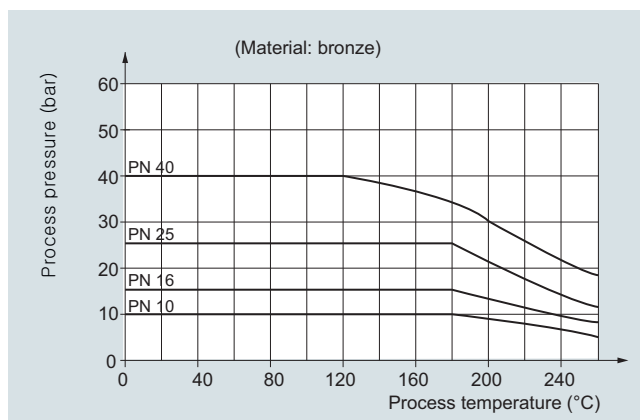
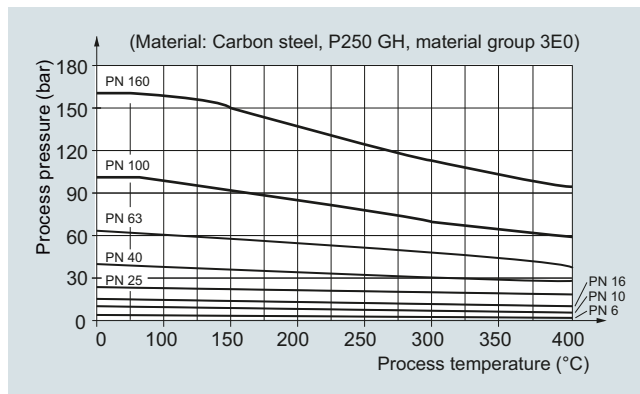

Pressure/temperature curve to ANSI B16.5 flanges

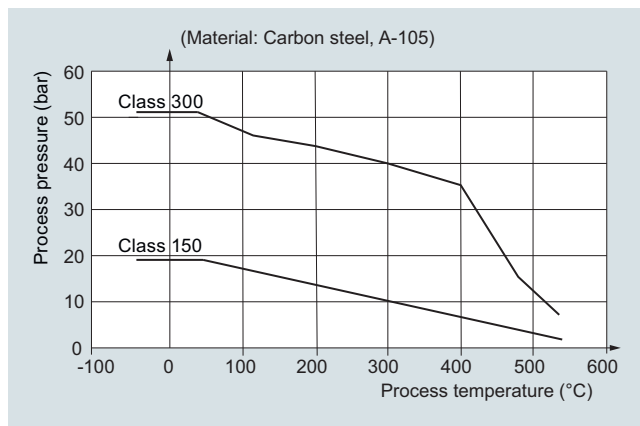

Note: The pressure/temperature curves only assist in the selection of a system. No responsibility is taken for the correctness of the information. For further information on the PED standard and requirements, see page 10/15.

Reference conditions

To ensure continuous accurate measurement, flowmeters must be calibrated. The calibration is conducted at Siemens flow facilities with traceable instruments referring directly to the physical unit of measurement according to the International System of Units (SI).

Therefore the calibration certificate ensures recognition of the test results worldwide, including the US (NIST traceability).

Siemens offer accredited calibrations assured to ISO 17025. Siemens Flow Instruments accredited laboratories are recognized by ILAC MRA (International Laboratory Accreditation Corporation - Mutual Recognition Arrangement) ensuring international traceability and recognition of the test results worldwide.

Flowmeter calibration data are stored in the internal EEPROM of the transmitters FUS060 or FUS080.

The system accuracy refers to the following systems:

SONO 3300/FUS060, SONO 3100/FUS060¹⁾ which are typically calibrated on the frequency output.

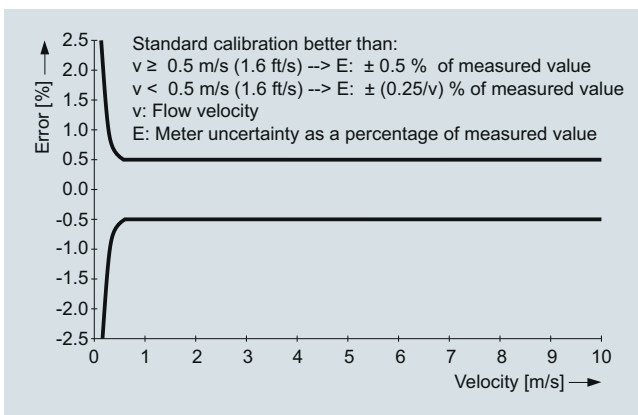

Typical calibration reference conditions:

Fluid	Water
Fluid temperature	$22 \pm 5 \text{ }^\circ\text{C}$
Ambient temperature	$22 \pm 5 \text{ }^\circ\text{C}$
Supply voltage	115/230 V AC +10 ... -15 % 24 V DC +25 ... -15 %, 24 V AC $\pm 15 \%$
Straight inlet length	$20 \times D_i$
Outlet	$3 \times D_i$
Rangeability	0 ... 1 m/s to 0 ... 10 m/s
Repeatability	Better than 0.25 % in the range 0.5 ... 10 m/s
Linearity (for water)	
• Reynolds number $1000 < Re < 5000$	Better than 1 %
• Reynolds number > 5000	Better than 0.5 %

¹⁾ Only systems with transmitter FUS060. For systems with transmitter FUS080 see chapter on FUS380 and FUE380.

Additional effects of deviations from reference conditions

- Current output: As frequency output ($\pm 0.1 \%$ of actual flow +0.05 % FSO)
- Effect of ambient temperature: Frequency/pulse output: $< 0.005 \% \text{ SPAN/K}$; Current output: $< \pm 0.0075 \% \text{ SPAN/K}$
- Effect of supply voltage: 0.005 % of measuring value at 1 % change

Flow Measurement

SITRANS F US InLine

Transmitter SITRANS FUS060

Overview



SITRANS FUS060 is a transit time based transmitter designed for ultrasonic flowmetering with dedicated sensors in the FUS in-line series up to DN 3000. SITRANS FUS060 is engineered for high performance and is suitable for 1-path, 2-path and 4-path flowmeters.

Benefits

- Superior signal resolution for optimum turn down ratio
- Simple menu-based local operation with two-line display and four optical input elements, for unlimited use in potentially explosive atmospheres
- Self-monitoring and diagnostic
- Operate up to 4 paths
- ATEX II 2 G Ex dem [ia/ib] IIC T6/T4/T3 Gb
- Remote installation up to 120 m from sensor
- 1 analog output (4 to 20 mA) standard with HART-protocol, 1 digital frequency or pulse output, 1 relay output for limit, alarms, flow direction
- PROFIBUS PA Profile 2, 1 digital frequency or pulse output

Design

The transmitter type FUS060 is designed for remote installation in non-hazardous or hazardous areas.

The transmitter is designed for use in a flowmeter system together with sensors type SONOKIT, SONO 3300 and SONO 3100.

The FUS060 is ordered as part of a complete flowmeter system. It can be ordered separately as spare part and manually programmed with the sensor data.

Application

The main application for flowmeters with the transmitter SITRANS FUS060 is measurement volume of flow within the general, petrochemical and chemical industries, power engineering and water and waste water, as well as various types of oils and liquid gases.

Integration

The transmitter output is often used as input for an automation system or as input for systems of remote reading.

The SITRANS FUS060 transmitter offers current, pulse and relay outputs as standard output functions and supports HART or Profibus PA communication.

The settings of the transmitter output functions are individually programmed via keypad and display menu.

Function

Displays and keypad

Operation of the SITRANS FUS060 transmitter can be carried out using:

- Keypad and display unit
- HART communicator
- PC/laptop and SIMATIC PDM software via HART communication
- PC/laptop and SIMATIC PDM software using PROFIBUS PA communication

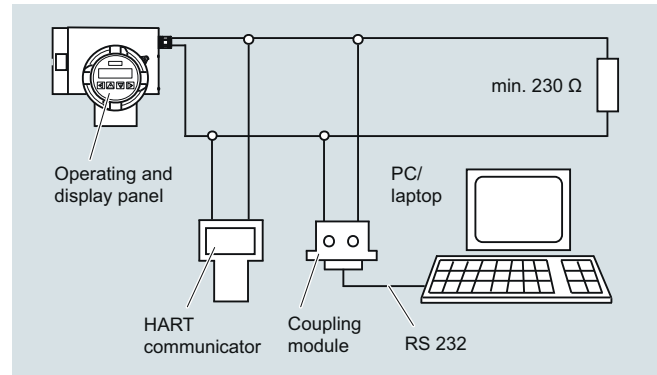

HART communication

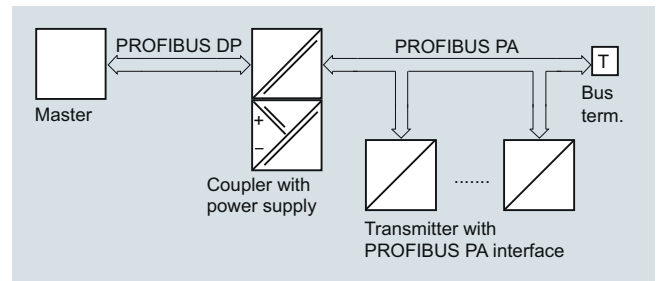

PROFIBUS PA communication

The operating and display panel permits simple operation without supplementary equipment. It is not necessary to open the housing. All changes to a setting can therefore also be carried out in the potentially explosive atmosphere.

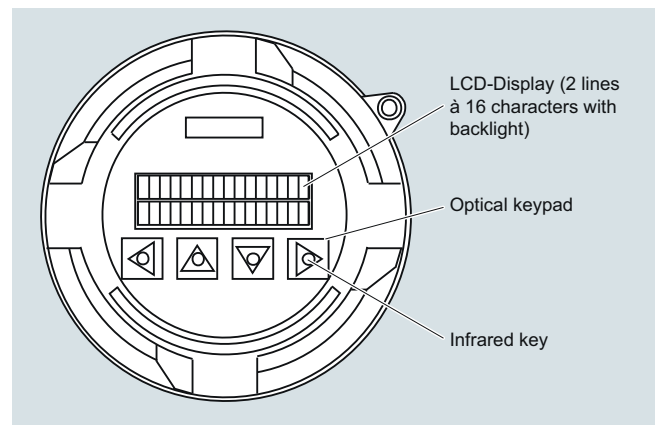

Operating and display panel

The individual functions and parameters are selected using a hierarchical, multi-language input menu and four infrared keys. The parameters can be specifically selected and modified using codes, e.g.:

- Operating parameters such as measuring range, physical dimensions, device information
- Limits for flow, totalizer, ultrasonic velocity or ultrasonic amplitude
- Noise suppression using damping, error stages and hysteresis
- Display parameters (freely-configurable display)
- Display in volume or mass dimensions
- Density as constant input value for conversion of volume into mass dimensions
- Forward/backward measurement
- Flow direction
- Diagnostics functions and control values
- Functions of the PROFIBUS PA output: flow, net quantity (volume or mass), ultrasonic velocity, ultrasonic amplitude, forward quantity (volume or mass), backward quantity (volume or mass)
- Functions of the analog output: flow, ultrasonic velocity or ultrasonic amplitude
- Functions of digital output 1: pulse output, frequency output, limit, flow direction or device status
- Functions of digital output 2: limit, flow direction or device status
- Simulation of output signal via analog output, digital output 1 and digital output 2

The HART protocol is implemented via the analog output (current output). Using this communication facility, the device can be parameterized with a PC/laptop and SIMATIC PDM software in addition to local operation.

In the version with PROFIBUS PA, the analog output is replaced by the digital PROFIBUS PA output. The device can then be parameterized via PROFIBUS communication and with SIMATIC PDM in addition to local operation.

Technical specifications

Input	
Measurement	Flow by measuring the transit time difference of ultrasonic signals through ultrasonic transducers in DN 100 (4") ... 3000 (120") 2-path sensor pipes (depending on selected size, 1-path or 4-path special solutions are possible).
Nominal diameters and number of paths	2-path DN 100 (4") ... DN 3000 (120") (depending on size, optionally also 1-path and 4-path)
Max. cable length	120 m (395 ft) (shielded coaxial cable). For Ex version the transducer cable length is restricted to 3 m (9.84 ft) in order to meet requirements for electrical immunity. For systems with sizes \geq DN 1500 (60") cable length is recommended to be max. 30 m (98.4 ft).
Analog output	
Function	Current output programmable for flow, sound velocity or amplitude level. Active current output (13.2 V < open loop voltage < 15.8 V) 4 ... 20 mA 20 ... 22.5 mA, adjustable 3.6 mA, 22 mA, or 24 mA Max. 600 Ω ; for non Ex version \geq 230 Ω for HART communication \leq 330 Ω for Ex-version
<ul style="list-style-type: none"> • Signal range • Upper limit • Signal on alarm • Load 	
<ul style="list-style-type: none"> • Only PROFIBUS PA version: 	Analog output omitted, is replaced by digital PROFIBUS PA interface
Digital output 1	
Function	Pulse, frequency or status output - programmable for pulses, frequency, alarm, limit or status.
<ul style="list-style-type: none"> • Active or passive signal, can be configured with positive or negative logic 	Active: 24 V DC, \leq 24 mA, $R_i = 300 \Omega$ Passive: open collector, 30 V DC, \leq 200 mA
<ul style="list-style-type: none"> • For explosion protection (ATEX version) and PROFIBUS PA version 	Only passive: open collector 30 V DC, \leq 100 mA
<ul style="list-style-type: none"> • Output function, configurable 	Pulse output <ul style="list-style-type: none"> • Adjustable pulse significance \leq 5000 pulses/s • Adjustable pulse width \geq 0.1 ms Frequency response <ul style="list-style-type: none"> • f_{END} selectable up to 10 kHz Limit for flow, totalizers, ultrasonic velocity or ultrasonic amplitude device status, flow direction

Flow Measurement

SITRANS F US Inline

Transmitter SITRANS FUS060

<p>Digital output 2</p> <p>Function</p> <ul style="list-style-type: none"> Relay, NC or NO contact For explosion protection (ATEX version) Output function, configurable Only PROFIBUS PA version: 	<p>Relay output - programmable for alarm, limit or status indication. Switching capacity max. 5 W Max. 50 V DC, max. 200 mA DC Self-resetting fuse, $R_i = 9 \Omega$</p> <p>Max. 30 V DC, max. 100 mA DC, 50 mA AC (cf. EC-Type Examination certificate)</p> <p>Limit for flow, ultrasonic velocity or ultrasonic amplitude flow direction device status</p> <p>Digital output 2 omitted</p>	<p>Rated operation conditions</p> <p><u>Ambient conditions</u></p> <p>Ambient temperature</p> <ul style="list-style-type: none"> Operation In potentially explosive atmospheres Storage <p>Enclosure rating</p> <p>Electromagnetic compatibility</p> <ul style="list-style-type: none"> Emitted interference Noise immunity <p><u>Medium conditions</u></p> <ul style="list-style-type: none"> Process temperature Gases/solids 	<p>-20 ... +50 °C (-4 ... +122 °F)</p> <p>Observe temperature classes</p> <p>-25 ... +80 °C (-13 ... +176 °F)</p> <p>IP65 (NEMA 4)</p> <p>For use in industrial environments</p> <p>To EN 55011/CISPR-11</p> <p>To EN/IEC 61326-1 (Industry)</p> <p>The measuring media must be ultrasonic signal compatible. It must be homogeneous and not two-phased to transfer the acoustic ultrasonic signals.</p> <p>-200 ... +250 °C (-328 ... +482 °F) (not directly influenced by medium temperature)</p> <p>Influence accuracy of measurement (approx. max. 3 % gases or solids)</p>
<p>Communication via analog output 4 ... 20 mA</p> <ul style="list-style-type: none"> PC/laptop or HART communicator with SITRANS F flowmeter Load with connection of coupling module Load with connection of HART communicator Cable Protocol 	<p>min. 230 Ω (max. 330 Ω for Ex-version)</p> <p>min. 230 Ω</p> <p>2-wire shielded ≤ 3 km (≤ 1.86 miles)</p> <p>Multi-core shielded ≤ 1.5 km (≤ 0.93 miles)</p> <p>HART, version 5.1</p>	<p>Design</p> <p>Separate version</p> <p>Enclosure material</p> <p>Wall mounting bracket (standard and special)</p> <p>Weight of transmitter</p> <p>Electrical connection</p>	<p>For ATEX versions mounted in the Ex area only with 3 m (9.8 ft) long cables.</p> <p>Transmitter is connected to the transducers via 3 ... 120 m (9.8 ... 395 ft) long specially shielded cables (coaxial cable)</p> <p>Die-cast aluminum, painted</p> <p>Stainless steel (standard: always incl.)</p> <p>4.4 kg (9.7 lb)</p> <p>Cable glands (always incl.)</p> <ul style="list-style-type: none"> Power supply and outputs <ul style="list-style-type: none"> 2 x M20 (HART)/M25 (PROFIBUS) or 2 x 1/2" NPT (HART) Transducers/sensor <ul style="list-style-type: none"> 2/4 x M16 or 2/4 x 1/2" NPT
<p>Communication via PROFIBUS PA interface</p> <ul style="list-style-type: none"> Power supply Current consumption from bus 	<p>Layers 1 + 2 according to PROFIBUS PA Communication system according to IEC 61158/EN 50170</p> <p>Separate supply, four-wire device Permissible bus voltage 9 ... 32 V See certificates and approvals</p> <p>10 mA; ≤ 15 mA in event of error with electronic current limiting</p>	<p>Displays and controls</p> <p>Display</p> <ul style="list-style-type: none"> Multi-display: 2 freely-selectable values are displayed simultaneously in two lines <p>Operation</p>	<p>For ATEX versions mounted in the Ex area only with 3 m (9.8 ft) long cables.</p> <p>4.4 kg (9.7 lb)</p> <p>Cable glands (always incl.)</p> <p>LCD, two lines with 16 characters each</p> <p>Flow, volume, mass flow, mass, flow velocity, speed of sound, ultrasonic signal information, current, frequency, alarm information</p> <p>4 infrared keys, hierarchical menu shown with codes</p>
<p>Electrical isolation</p>	<p>Outputs electrically isolated from power supply and from one another</p>	<p>Power supply</p> <p>Supply voltage</p> <ul style="list-style-type: none"> Standard version Ex version <p>Power failure</p> <p>Power consumption</p>	<p>120 ... 230 V AC ± 15 % (50/60 Hz) or 19 ... 30 V DC/21 ... 26 V AC</p> <p>19 ... 30 V DC/21 ... 26 V AC</p> <p>No effect for at least 1 period (> 20 ms)</p> <p>Approx. 10 VA/10 W</p>
<p>Accuracy</p> <p>Error in measurement (at reference conditions)</p> <ul style="list-style-type: none"> Pulse output Analog output 4 ... 20 mA Repeatability <p>Reference conditions (water)</p> <ul style="list-style-type: none"> Process temperature in the connected sensor Ambient temperature at the transmitter Transmitter warming-up time <p>Installation conditions of connected sensor</p>	<p>Outputs electrically isolated from power supply and from one another</p> <p>$\leq \pm 0.5$ % of measured value at 0.5 ... 10 m/s or $\leq \pm 0.25\sqrt{V}$ [m/s] % of measured value at flow < 0.5 m/s</p> <p>As pulse output plus ± 0.1 % of measured value, $\pm 20 \mu\text{A}$</p> <p>$\leq \pm 0.25$ % of measured value at 0.5 ... 10 m/s</p> <p>25 °C ± 5 °C (77 °F ± 9 °F)</p> <p>25 °C ± 5 °C (77 °F ± 9 °F)</p> <p>30 min.</p> <p>Upstream section > 10 x DN and downstream section > 5 x DN</p>	<p>Certificates and approvals</p> <p>Explosion protection</p>	<p>Certificates and approvals</p> <p>Explosion protection</p> <p>ATEX II 2 G Ex dem [ia/ib] IIC T6/T4/T3 Gb</p> <p>T6 for media < 85 °C (185 °F)</p> <p>T5 for media < 100 °C (212 °F)</p> <p>T4 for media < 135 °C (275 °F)</p> <p>T3 for media < 200 °C (392 °F)</p>

Coaxial cable

Standard Coaxial cable (75 Ω)

Coaxial cable with SMB straight plug on one end for connection to the FUS060

Pre-terminated, can be shortened on sensor side



Outside diameter	Ø 5.8 mm
Length	3, 15, 30, 60, 90, 120 m (9.84, 49.21, 98.43, 196.85, 295.28, 393.70 ft) between sensor and transmitter
Material (outside jacket)	black PE
Ambient temperature	-10 ... +70 °C (14 ... 158 °F)

High temperature Coaxial cable (75 Ω)

Coaxial cable with SMB straight plug on one end for the connection to FUS060

Fix terminated, can NOT be shortened

Outside diameter	Ø 5.13 mm (first 0.3 m (0.98 ft) part to the transducer), Ø 5.8 mm (for remaining cable to the transmitter - with SMB plug at the end) and between these is a black hot melt junction Ø 16 mm (length 70 mm)
Length	3, 15, 30 m (9.84, 49.21, 98.43 ft) between sensor and transmitter (max 3 m 9.84 ft) transducer cable length for Ex area mounted transmitters)
Material (outside jacket)	Brown PTFE (0.3 m (0.98 ft) part) and black PE (for remaining cable)
Ambient temperature	-200 ... +200 °C (-328 ... +392 °F) (brown PTFE transducer part) and -10 ... +70 °C (14 ... 158 °F) (black PE for remaining transmitter cable part)

Dimensional drawings

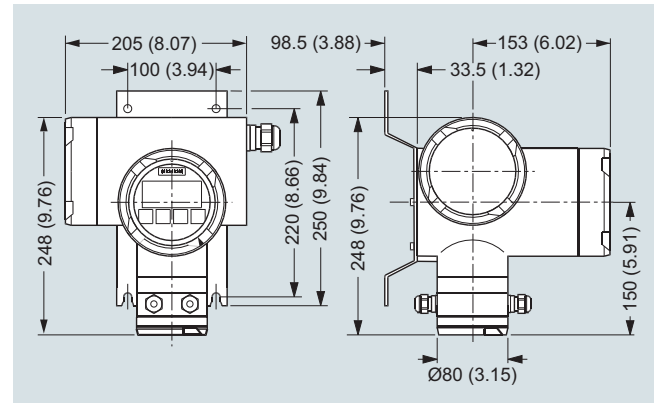

SITRANS FUS060 with standard mounting bracket, dimensions in mm (inch)

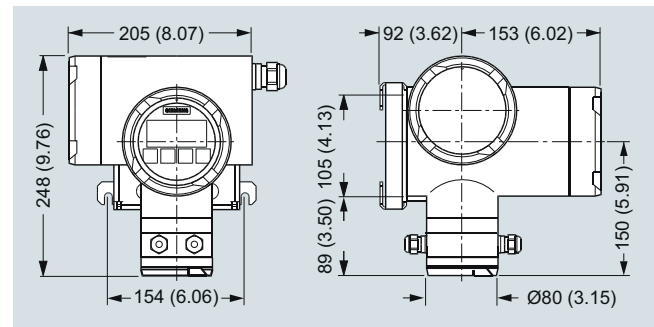

SITRANS FUS060 with optional special mounting bracket, dimensions in mm (inch)

Schematics

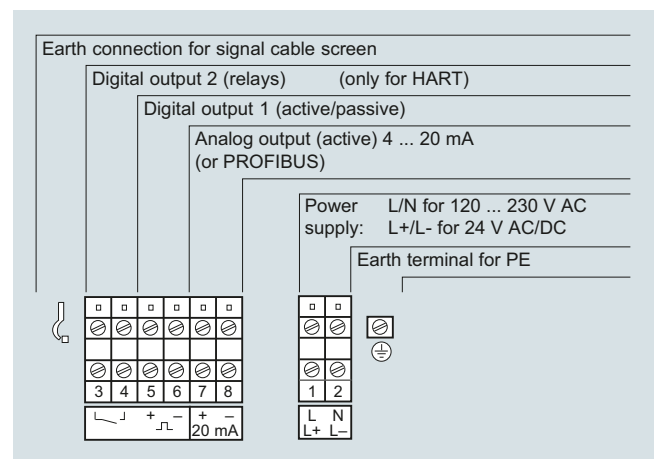

Electrical connection SITRANS FUS060

Flow Measurement

SITRANS F US Inline

Transmitter SITRANS FUS060



Transmitter FUS060 operating instructions, accessories and spare parts

Operating instructions

Description	Article No.
• English	A5E01204521
• German	A5E02123845

All literature is available to download for free, in a range of languages, at www.siemens.com/processinstrumentation/documentation

Accessories

Description	Article No.	
Standard wall mounting bracket	7ME5933-0AC04	
Special wall-/pipe mounting bracket kit	7ME5933-0AC05	
Safety clamp for electronic cover with glass plate (7ME5933-0AC01)	7ME5933-0AC06	

Process Device Manager SIMATIC PDM

SIMATIC PDM

Details about the SIMATIC PDM tool can be found on page 8/5, chapter "Communication and Software"

See page 8/13, chapter "Communication and Software"



HART modem for communication with FUS060 HART, PC and SIMATIC PDM

HART modem

With USB connection

7MF4997-1DB













Spare parts

SITRANS FUS060 transmitter, available standard and Ex versions

The transmitter configuration is made in the flowmeter Order codes (together with the sensors). The information below is for spare part ordering only and with fixed standardized pre-settings for a DN 2000 2-path system.

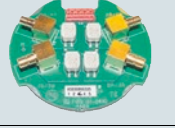
Description	Version	Enclosure	Supply	Article No.	
FUS060, 230 V, HART, Metric cable glands	Transmitter for remote connection	IP65 (NEMA 4)	115 ... 230 V AC 50/60 Hz	7ME3050-2BA10-1BA1	
FUS060, 230 V, HART, Imperial cable glands	Transmitter for remote connection	IP65 (NEMA 4)	115 ... 230 V AC 50/60 Hz	7ME3050-2BA10-1BA2	
FUS060, 230 V, PROFIBUS, Metric cable glands	Transmitter for remote connection	IP65 (NEMA 4)	115 ... 230 V AC 50/60 Hz	7ME3050-2BA10-1DA1	
FUS060, 230 V, PROFIBUS, Imperial cable glands	Transmitter for remote connection	IP65 (NEMA 4)	115 ... 230 V AC 50/60 Hz	7ME3050-2BA10-1DA2	
FUS060, 24 V, HART, Metric cable glands	Transmitter for remote connection	IP65 (NEMA 4)	19 ... 30 V DC/ 21 ... 26 V AC	7ME3050-2BA20-1BA1	
FUS060, 24 V, HART, Imperial cable glands	Transmitter for remote connection	IP65 (NEMA 4)	19 ... 30 V DC/ 21 ... 26 V AC	7ME3050-2BA20-1BA2	
FUS060, 24 V, PROFIBUS, Metric cable glands	Transmitter for remote connection	IP65 (NEMA 4)	19 ... 30 V DC/ 21 ... 26 V AC	7ME3050-2BA20-1DA1	
FUS060, 24 V, PROFIBUS, Imperial cable glands	Transmitter for remote connection	IP65 (NEMA 4)	19 ... 30 V DC/ 21 ... 26 V AC	7ME3050-2BA20-1DA2	
FUS060, ATEX, 24 V, HART, Metric cable glands	Transmitter for remote connection	IP65 (NEMA 4) ATEX approval	19 ... 30 V DC/ 21 ... 26 V AC	7ME3050-2BA21-1CA1	

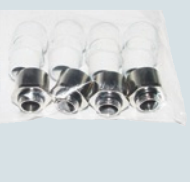
Ordering of pre-configured FUS060 spare transmitters only via PVR (product variation request - special request)

Description	Article No.		Description	Article No.	
Operating/Display module	7ME5933-0AC00		M20 cable gland set for FUS060 ATEX version power and output connection, PA plastic, 1 x in blue (ATEX Ex i) and 1 x gray (ATEX Ex-e) • cables Ø 5 ... 9 mm (0.20" ... 0.35") • -20 ... +95 °C (-4 ... +203 °F)	A5E02246356	
Electronics cover with glass plate (non Ex) . Die cast aluminum, with corrosion-resistant Basic Polyester powder coating (min. 60 µm)	7ME5933-0AC01		1/2" NPT cable gland set for FUS060 (NPT) power and output connection, gray PA plastic, 2 pcs. • cables Ø 6 ... 12 mm (0.24" ... 0.47") • -40 ... +100 °C (-40 ... +212 °F)	A5E02246396	
Cover for sensor cable and gasket. Die cast aluminum, with corrosion-resistant Basic Polyester powder coating (min. 60 µm)	7ME5933-0AC02		M25 cable gland set for the FUS060 PA (M25) power and output connection, gray PA plastic, 2 pcs. • cables Ø 9 ... 16 mm (0.35" ... 0.63") • -40 ... +100 °C (-40 ... +212 °F)	A5E02246378	
Cover for mains supply/communication. Die cast aluminum, with corrosion-resistant Basic Polyester powder coating (min. 60 µm)	7ME5933-0AC03		M16x1.5 cable gland set for FUS060 (M16) sensor connection, gray PA plastic, 2 pcs. and 2 pcs. blind. • cables Ø 5 ... 9 mm (0.20" ... 0.35") • -40 ... +100 °C (-40 ... +212 °F)	A5E02593526	
FUS060 Sensor connection PCBA, Standard versions only, 1 pc.	A5E02551331		M16 x 1.5 cable gland set for FUS060 (M16) sensor connection, brass chrome, 2 pcs. and 2 pcs. blind • cables Ø 5 ... 9 mm (0.20" ... 0.35") • -20 ... +105°C (-4 ... +221 °F)	A5E02246369	
FUS060 Sensor connection PCBA, ATEX version only, 1 pc.	A5E02551334		1/2" NPT cable gland set for FUS060 (NPT) sensor connection, 4 pcs. M16 bush to 1/2" NPT and 4 pcs. 1/2" NPT gray PA plastic glands • cables Ø 5 ... 9 mm (0.20 ... 0.35") • -20 ... +100 °C (-4 ... +212°F)	A5E02247877	
M20 cable gland set for FUS060 (M20) power and output connection, gray PA plastic, 2 pcs. • cables Ø 6 ... 12 mm (0.24" ... 0.47") • -40 ... +100 °C (-40 ... +212 °F)	A5E02246350				

Flow Measurement

SITRANS F US Inline

Transmitter SITRANS FUS060

Cables for FUS060

Description	Length m (ft)	Article No.
Coaxial cable for FUS060, (75 Ω, max. 70 °C (158 °F), black PVC) (2 pcs.)	3 (9.84)	A5E00875101
	15 (49.21)	A5E00861432
	30 (98.43)	A5E01278662
	60 (196.85)	A5E01278682
	90 (295.28)	A5E01278687
	120 (393.70)	A5E01278698
High temp. coaxial cable for FUS060; with 0.3 m brown PTFE high temp. transducer part, max. 200 °C (392 °F) and black PVC for remaining transmitter part with SMB plug, max. 70 °C (158 °F), impedance 75 Ω (2 pcs.)	3 (9.84)	A5E00875105
	15 (49.21)	A5E00861435
	30 (98.43)	A5E01196952
Special coaxial cable sets for low temperature cryogenic systems; with SMB plug for transmitter SITRANS FUS060, PTFE material, temp. -200 ... +200 °C (-328 ... +392 °F), impedance 75 Ω (2 pcs.)	10 (32.84)	A5E02085593
	15 (49.21)	A5E03262088
	30 (98.43)	A5E02085644
	40 (131.23)	A5E02085649



Overview



SITRANS FUS080 is a transit time based transmitter designed for ultrasonic flow metering with any sensor in the FUS inline series SONOKIT, FUS380 and FUE380 up to DN 1200.

The ultrasonic flowmeter transmitter SITRANS FUS080 comes as battery or mains powered version. The SITRANS FUS080 is designed to measure flow water applications.

The SONOKIT retrofit flowmeter series are shown from page 3/277. The standard flowmeter series SITRANS FUS380 is described from page 3/288. The type approved flowmeter series for flow metering in energy meter custody transfer systems are named SITRANS FUE380 - see page 3/294.

Benefits

- Battery-powered up to 6 years
- 115/230 V mains-powered with back-up battery option in case of mains power failure
- Fast measuring frequency 15 Hz/0.5 Hz (230 V AC/Battery)
- Easy one button straight forward display
- IrDA optical interface for local communication
- 2-path measuring principle for optimum accuracy
- Compact or remote mounting
- Measures on all district water qualities and water conductivities
- No pressure drop
- Long-term stability
- 2 galvanic isolated digital outputs for easy connection to a calculator (potential free)
- 1 analog 4 to 20 mA output
- Bidirectional measurement, with 2 totalizers and outputs
- Dynamic range Q_i (min) : Q_s (max) up to 1:400
- Compact version with triax cables for highest EMC-protection

Application

The main application for flowmeters with the transmitter SITRANS FUS080 is measurement of water flow in district heating plants, local networks, boiler stations, substations, chiller plants, irrigations plants and other general water applications.

Design

The transmitter type SITRANS FUS080 is designed with fiber-glass reinforced polyamide enclosure for remote or compact installation in normal areas. The remote versions are available with up to 30 meter distance from flowmeter to transmitter. When ordering as a compact version in the series FUS380 and FUE380 the transducer cables are pre-mounted at the sensor.

The transmitter is available in an IP67/NEMA 4X/6 enclosure and is designed for use in the flowmeters series:

- SONOKIT (1-path or 2-path)
- FUS380 (2-path)
- FUE380 (2-path)

The transmitter FUS080 is always ordered as part of a complete flowmeter system.

It can be manually ordered separately as spare part pre-programmed with the given sensor data.

Integration

The flowmeter pulse output is often used as input for an energy meter or as input for digital systems for remote reading.

SITRANS FUS380 has two pulse outputs, with functions that can be individually selected.

The settings of the transmitter, eg. flow and pulse output rate, are defined when ordering the complete flowmeter.

If the flowmeter forms part of an energy meter system for custody transfer, no further approvals are needed, except eventually local approvals on the flowmeter.

Technical specifications

Input	
Measurement	Flow by measuring the transit time difference of ultrasonic signals through ultrasonic transducers in the sensor pipes. Supporting of 1-path or 2-path sensors in sizes DN 50 ... 1200 measuring on water.
Measuring rate	
• Battery mode	0.5 Hz
• Mains supply	Up to 15 Hz
• Back-up mode	0.5 Hz (at mains supply drop)
Flow rate	0.02 ... 9 m/s (0.065 ... 29.5 ft/s), bidirectional flow metering
Output	
Max. pulse frequency	100 Hz at Q_s (Q_{max})
Pulse value and length	Selectable with the ordering of the flowmeter
Output A function	Pulse: forward, reverse, forward net, reverse net (preset: forward)
Output B function	Pulse: forward, reverse, forward net, reverse net (preset: forward) or alarm indication or call-up indication (preset: alarm)
Pulse value A and B	0.1 l/p, 0.25 l/p, 0.5 l/p, 1 l/p, 2.5 l/p, 10 l/p, 25 l/p, 50 l/p, 100 l/p, 250 l/p, 500 l/p, 1 m ³ /p, 2.5 m ³ /p, 5 m ³ /p, 10 m ³ /p, 25 m ³ /p, 50 m ³ /p, 100 m ³ /p, 250 m ³ /p, 500 m ³ /p, 1 000 m ³ /p
Pulse length (depending on Q_{max} by DN selection)	5, 10, 20, 50, 100, 200, 500 ms (standard 5 ms)
Alarm indication	Path 1 (F1), path 2 (F2) internal, failure (F3, F4), powers supply warning or low battery indication (F5), Q_{max} overflow (F6), pulse overflow (F7, F8), internal data logger warning (F9)
Analog output	Passive current output 4 ... 20 mA Data span pre-selectable depending on pipe size

Flow Measurement

SITRANS F US Inline

Transmitter SITRANS FUS080/FUE080

Rated operation conditions

Ambient conditions

Ambient temperature

- Operation -10 ... +60 °C (14 ... 140 °F) (MID version: max. +55 °C (131 °F))
- Storage -40 ... +85 °C (-40 ... +185 °F) (battery included)

Enclosure rating

IP67/NEMA 4X/6 to EN 60529 and DIN 40050

Electromagnetic compatibility

- Emitted interference To EN 55011/CISPR-11
- Immunity To EN/IEC 61326-1 (Industry)
- MID approved (FUE380 series) Environment class E2 and M1

Mechanical vibration

2 g, 1 ... 800 Hz sinusoidal in all directions according to IEC 68-2-6

Weight of transmitter

Approx. 1.5 kg (3.3 lb)

Design

Enclosure material

Fibre-glass reinforced polyamide, light gray color

Wall mounting kit

IP67/NEMA 4X/6 terminal box for the wall mounting of the transmitter, fiber-glass reinforced polyamide with stainless steel bracket, cable glands entries: 2 x 2 M20 or PG 13.5 for power supply and outputs and 2 x M20 or PG 13.5 for the sensor cables, glands (supply and outputs and double cable entries for sensor cables) are included.

Sensor cable

Coaxial cable sets for remote transmitter up to 30 m (98.4 ft) long transducer cable, 75 Ω impedance, cables sets are prepared for the connection to the sensors
Triax cables for integral version

Display and controls

Display

LCD, 8 digits, additional 2 digits and symbols for status information

Resolution

Totalized information can be displayed with 1, 2 or 3 decimals or automatic adjustment (default)

Display setting

Flow unit: Preset: m³/h
Volume unit: Preset: m³

Push button

One push button for menu selection and display information

Communication (IrDA optical eye)

IrDA – optical communication and control interface with Modbus RTU protocol for read or write transmitter settings and data via PC and PDM tool

Power supply

Battery

D-cell battery pack, 3.6 V LiSOCl (Lithium Thionyl Chloride, 34 Ah), replaceable, life- and working-time up to 6 years

Mains

87 ... 265 V AC (50 ... 60 Hz) or 87 ... 265 V AC (50 ... 60 Hz) with D-cell single battery backup, 2.6 V LiSOCl (Lithium Thionyl Chloride, 17 Ah), replaceable, life time up to 8 years

Power consumption

Mains version

Approx. 2.5 VA

SONOKIT, FUS380, FUE380

The flow values and settings are predefined according to dimension selection.

The transmitter settings are changeable by using the SW tool PDM (for FUE380 series some of the setting are only readable, restriction of the approval requirements).

Accuracy/Error in measurement:

(at reference conditions for FUS380 and FUE380 series, SONOKIT series will differ in the accuracy)

- Pulse output
 - $\leq \pm 0.5$ % of measured value at 0.5 ... 10 m/s or
 - $\leq \pm 0.25/V$ [m/s] % of measured value at flow < 0.5 m/s
- Repeatability ≤ 0.25 % of measured value at 0.5 ... 10 m/s
- Reference conditions
 - Process temperature and ambient temperature: 25 °C \pm 5 °C (77 °F \pm 9 °F)
 - Transmitter warming-up time 30 min.
 - Installation conditions of the sensor: Upstream section > 10 x DN and downstream section > 5 DN

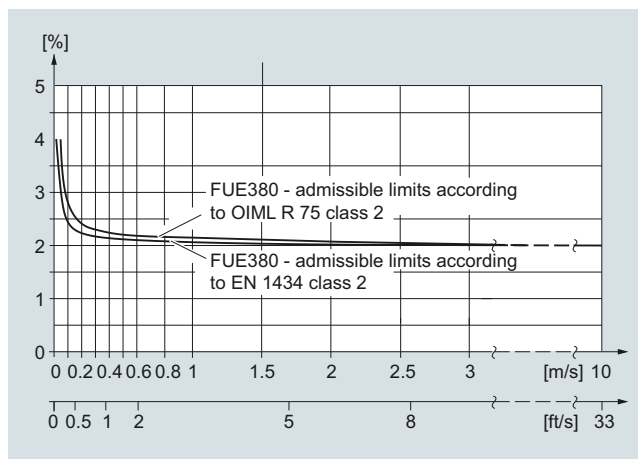
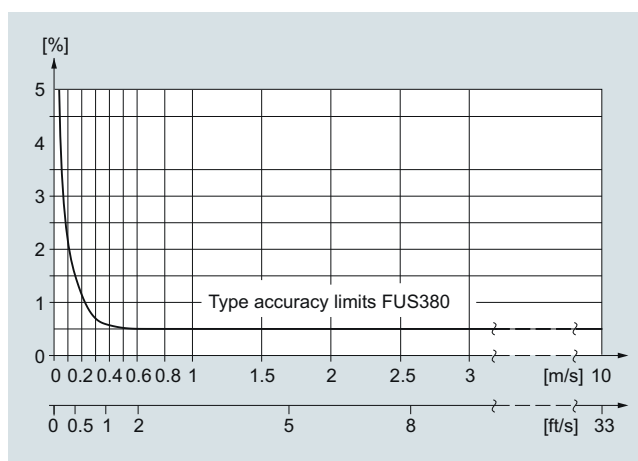

Output configuration

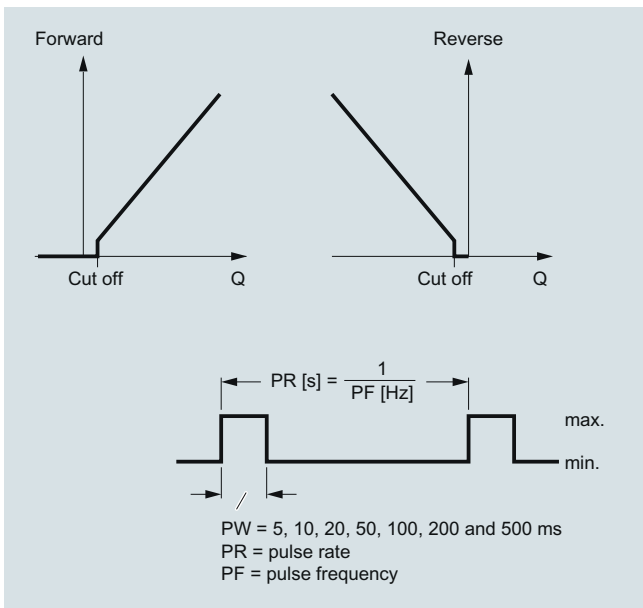

Pulse volume: output A/B configured as volume per pulse, calculated on forward/reverse or net forward/reverse flow. The volume per pulse is free scaleable (via PDM software).

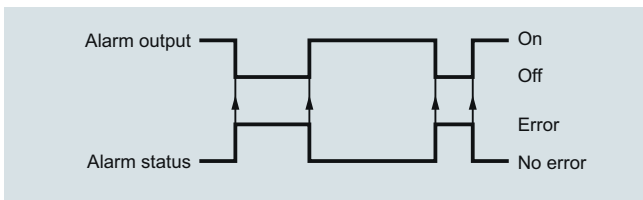

Pulse output B can be used as stated above or as alarm or call-up function.

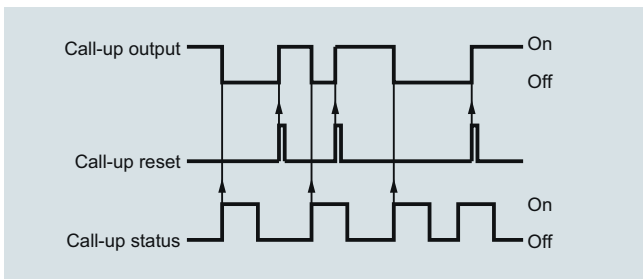

Call-up: the call-up output is active until manually reset by use of PDM tool. The call-up function is activated when an alarm is activated.

Current output

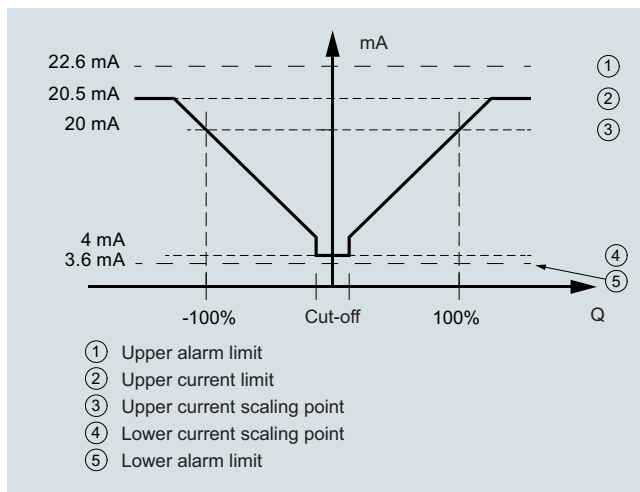

Bidirectional flow

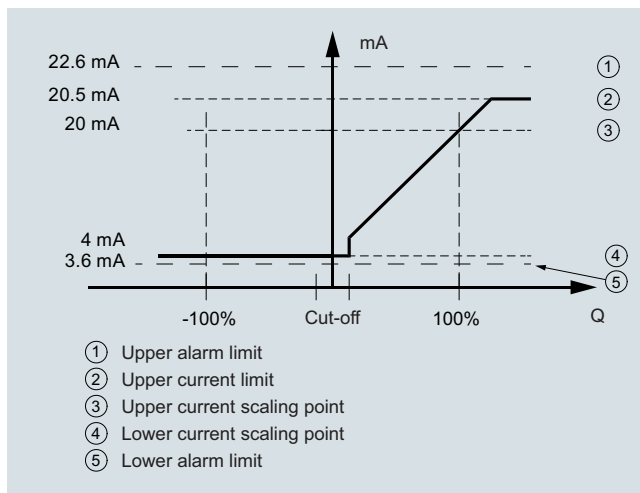

Positive flow

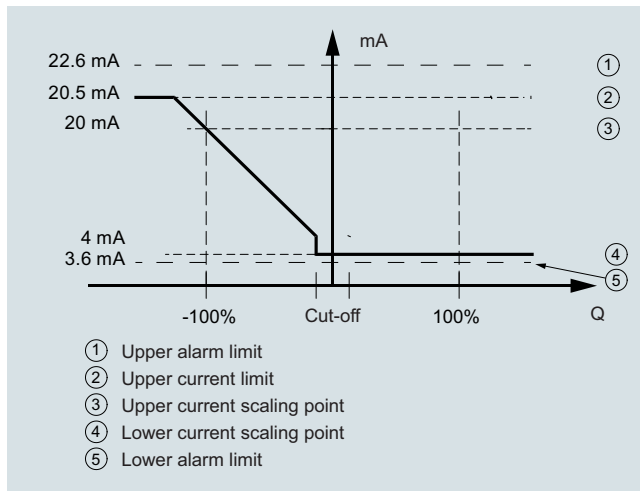

Negative flow

Flow Measurement

SITRANS F US Inline

Transmitter SITRANS FUS080/FUE080

Sensor coaxial cable for SONOKIT series with FUS080

Coaxial cable		
Standard coaxial cable (75 Ω)		
Outside diameter	Ø 5.8 mm	
Length	15, 30 m (49.2, 98.4 ft) between sensor and transmitter	
Material (outside jacket)	Black PE	
Ambient temperature	-10 ... +70 °C (14 ... 158 °F)	

Sensor coaxial cable for FUS380/FUE380 series

Coaxial cable		
High temperature coaxial cable (75 Ω)		
	With special designed glands for connection in the sensor/transducer	
Outside diameter	Ø 5.13 mm (first 0.3 m (0.98 ft) part to the transducer), Ø 5.8 mm (for remaining cable to the transmitter – black holt melt junction part between (Ø 16 mm, length 70 mm)	
Length	Up to 30 m (98.4 ft) between sensor and transmitter	
Material (outside jacket)	Brown PTFE (0.3 m (9.84 ft) part) and black PE (for remaining cable)	
Ambient temperature	-200 ... +200 °C (-328 ... +392 °F) (brown PTFE transducer part) and -10 ... +70 °C (14 ... 158 °F) (black PE for remaining transmitter cable part)	

Transmitter FUS080 operating instructions, accessories and spare parts

Operating instructions

Description	Article No.
for use with SONOKIT • English	A5E03059912
integrated in FUS/FUE380 • English • German	A5E00730100 A5E00740611

All literature is available to download for free, in a range of languages, at www.siemens.com/processinstrumentation/documentation

Accessories

Description	Article No.
Sun lid for FUS080 transmitter (frame and lid)	A5E02328485
Brace (holder) for optical IrDA eye	A5E00695277
IrDA infrared interface adapter with USB for data acquisition with 1.2 m (3.9 ft) cable	FDK:087L4163

Process Device Manager SIMATIC PDM

SIMATIC PDM Details about the SIMATIC PDM tool can be found on page 8/5, chapter "Communication and Software"	See page 8/13, chapter "Communication and Software"
---	--

Spare parts

A spare part transmitter can be ordered for a specific system. In the description of the following spare part transmitters the related transmitter Article No. found on the device silver front label is noted.

Spare part transmitter for FUS380 systems (7ME3400)

Description	Article No.
FUS080 transmitter 3.6 V battery (no battery included, to be ordered separate) as spare part transmitter for FUS380 flowmeter series. Transmitter Article No. 7ME3450-0AA10-2AA0	A5E02729700
FUS080 transmitter 3.6 V battery (battery included) as spare part transmitter for FUS380 flowmeter series ¹⁾ . Transmitter Article No. 7ME3450-0AA20-2AA0	A5E02729035
FUS080 transmitter 230 V mains as spare part transmitter for FUS380 flowmeter series. Transmitter Article No. 7ME3450-0AA30-2AA0	A5E02699309
FUS080 transmitter 230 V mains with backup-battery as spare part transmitter for FUS380 flowmeter series. Transmitter Article No. 7ME3450-0AA40-2AA0	A5E02729610

When ordering: Inform on flowmeter Article No. and flowmeter serial no. (e.g. 7ME3400-xxxx-xxxx-Z, XX.... and xxxxxxHxxx)

Spare part transmitter for FUE380 approved systems (7ME3410)

(only with MID approval marks, no MID verification – only a complete flowmeter can be MID-verified, i.e. sensor together with the transmitter)

Description	Article No.
FUE080 transmitter 3.6 V battery (no battery included, to be ordered separate) as spare part transmitter for FUE380 flowmeter series. Transmitter Article No. 7ME3450-0AA10-2AB0	A5E02734600
FUE080 transmitter 3.6 V battery (battery included) as spare part transmitter for FUE380 flowmeter series ¹⁾ . Transmitter Article No. 7ME3450-0AA20-2AB0	A5E02734568
FUE080 transmitter 230 V mains as spare part transmitter for FUE380 flowmeter series. Transmitter Article No. 7ME3450-0AA30-2AB0	A5E02734539
FUE080 transmitter 230 V mains with backup-battery as spare part transmitter for FUE380 flowmeter series. Transmitter Article No. 7ME3450-0AA40-2AB0	A5E02734585

When ordering: Inform on flowmeter Article No. and flowmeter serial no. (e.g. 7ME3410-xxxx-xxxx-Z, XX.... and xxxxxxHxxx)

Spare part transmitter for SONOKIT systems (7ME3210/7ME3220)

Description	Article No.
FUS080 transmitter 3.6V battery (no battery included, to be ordered separate) as spare part transmitter for SONOKIT flowmeters. Transmitter Article No. 7ME3450-0AA10-2AA0	A5E03048726
FUS080 transmitter 3.6V battery (battery included) as spare part transmitter for SONOKIT flowmeters ¹⁾ . Transmitter Article No. 7ME3450-0AA20-2AA0	A5E03048714
FUS080 transmitter 230V mains as spare part transmitter for SONOKIT flowmeters. Transmitter Article No. 7ME3450-0AA30-2AA0	A5E03048701
FUS080 transmitter 230V mains with backup-battery as spare part transmitter for SONOKIT flowmeters. Transmitter Article No. 7ME3450-0AA40-2AA0	A5E03048719

When ordering: Inform on flowmeter Article No. and flowmeter serial no. (e.g. 7ME3220-xxxx-xxxx-Z, XX.... and xxxxxxHxxx)











¹⁾ Lithium batteries are subject to special transportation regulations according to United Nations "Regulation of Dangerous Goods, UN 3090 and UN 3091". Special transport documentation is required to observe these regulations. This may influence both transport time and costs.

Flow Measurement

SITRANS F US Inline

Transmitter SITRANS FUS080/FUE080

Spare part transmitter for FUS880 retrofitting systems (7ME3440)

Description	Article No.		Description	Article No.	
<p>Sparepart FUS080 transmitter 3.6 V, incl. 3.6V dual batterie pack, USA version</p> <p>Transmitter Article No.: 7ME3450-0AA20-1CA0; Label, 0: Siemens FUS080 transmitter; Version, 0: Without connection box; Enclosure, A: IP67/NEMA 4X/6; Code A: Standard; Supply Voltage, 2: 3.6V DC battery; Ex. Approval, 0: no Ex approval; Display, 1: With display and unit label; Region version, C: USA: AcFt,CFS; Application, A: Standard FUS080 (for SITRANS Retrofit - 7ME344); Code, 0: Standard</p>	A5E03412669		<p>Internal battery pack, one set of 2 D-cell (3.6 V 34 Ah)¹⁾</p> <ul style="list-style-type: none"> 1 pc. pack 24 pcs. pack 	A5E02679676 A5E02896941	
			<p>Single battery back-up to main supply (17 Ah)¹⁾</p>	A5E02679923	
			<p>Battery cover for transmitter FUS080</p>	A5E00694468	
			<p>PG 13.5 cable gland set for FUS080 power and output connection, black PA plastic, 2 pcs.</p> <ul style="list-style-type: none"> cables Ø 6 ... 12 mm (0.24" ... 0.47") -40 ... +100 °C (-40 ... +212 °F) 	FDK:083G0228	
			<p>PG 13.5 cable gland set (two cable entries) for FUS080 sensor connection, black PA plastic, 2 pcs.</p> <ul style="list-style-type: none"> cables Ø 6 ... 12 mm (0.24" ... 0.47") -40 ... +100 °C (-40 ... +212 °F) 	A5E00694500	
<p>FUS080 transmitter for FUS880 retrofit systems, USA version,</p> <p>incl. wall-mounting kit, 2 transducers and 2 pcs. 60 ft (20 m) of cables.</p> <p>Label, 0: Siemens FUS080 transmitter; Diameter, 0A: None; Wall Thickness, A: None; Pipe Material, 0: No Pipe; Track configuration, 1: 1-Track; Region version, 2: USA: AcFt,CFS; Transmitter, D: FUS080,IP67, Battery, Remote, unit label; Template, A: None; Transducer coax cable, 4: 20 m with gland</p>	7ME3440-0AA01-2DA4				
			<p>SITRANS FUS/FUE380 wall mounting kit for remote transmitter mounting, including connection plate (DN 50 ... DN 1200/2" ... 48")</p>	A5E00694509	
			<p>SITRANS FUS/FUE380 terminal box for compact transmitter mounting, including connection plate, (bronze sensors only, DN 50 ... DN 80/2" ... 3")</p>	A5E01208138	
			<p>SITRANS FUS/FUE380 terminal box for compact transmitter mounting, including connection plate, (steel sensors only, DN 100 ... DN 1200/4" ... 48")</p>	A5E00694660	
<p>FUS080 transmitter for FUS880 retrofit systems, USA version,</p> <p>incl. wall-mounting kit, 4 transducers and 4 pcs. 60 ft (20 m) of cables:</p> <p>Label, 0: Siemens FUS080 transmitter; Diameter, 0A: None; Wall Thickness, A: None; Pipe Material, 0: No Pipe; Track configuration, 3: 2-Track (X-Configuration); Region version, 2: USA: AcFt,CFS; Transmitter, D: FUS080 ,IP67, Battery, Remote,unit label; Template, A: None; Transducer coax cable, 4: 20 m with gland</p>	7ME3440-0AA03-2DA4		<p>FUS080 display and keypad with Siemens logo</p>	A5E00873496	
			<p>FUS080 display and keypad neutral (without logo)</p>	A5E33147123	

¹⁾ Lithium batteries are subject to special transportation regulations according to United Nations "Regulation of Dangerous Goods, UN 3090 and UN 3091". Special transport documentation is required to observe these regulations. This may influence both transport time and costs.

Sensor cables for FUS380/FUE380 flowmeters

Description	Article No.	
DN 50 to 80 flowmeters		
Coaxial cable for FUS080; with 0.3 m brown PTFE high temp. transducer part, max. 200 °C (392 °F) and black PVC for remaining transmitter part, max. 70 °C (158 °F); impedance 75 Ω		
5 m (16.4 ft) cable set (4 pcs.) for DN 50 ... DN 80 (2" ... 3") remote mounting	A5E01208092	
10 m (32.8 ft) cable set (4 pcs.) for DN 50 ... DN 80 (2" ... 3") remote mounting	A5E01208114	
20 m (65.6 ft) cable set (4 pcs.) for DN 50 ... DN 80 (2" ... 3") remote mounting	A5E01208117	
30 m (98.4 ft) cable set (4 pcs.) for DN 50 ... DN 80 (2" ... 3") remote mounting	A5E01208121	
0.5 m (1.64 ft) cable set (4 pcs.) for DN 50 ... DN 80 (2" ... 3") for compact version of FUS380/FUE380	A5E01208126	
DN 100 to 1200 flowmeters		
Coaxial cable for FUS080; with 0.3 m brown PTFE high temp. transducer part, max. 200 °C (392 °F) and black PVC for remaining transmitter part, max. 70 °C (158 °F); impedance 75 Ω		
5 m (16.4 ft) cable set (4 pcs.) for DN 100 ... DN 1200 (4" ... 48") remote mounting	A5E00695476	
10 m (32.8 ft) cable set (4 pcs.) for DN 100 ... DN 1200 (4" ... 48") remote mounting	A5E00695479	
20 m (65.6 ft) cable set (4 pcs.) for DN 100 ... DN 1200 (4" ... 48") remote mounting	A5E00695480	
30 m (98.4 ft) cable set (4 pcs.) for DN 100 ... DN 1200 (4" ... 48") remote mounting	A5E00695483	
1 m (3.28 ft) cable set (4 pcs.) for DN 100 ... DN 1200 (4" ... 48") for compact version of FUS380/FUE380	A5E00695486	

Sensor cables for SONOKIT flowmeter with FUS080

Description	Article No.	
15 m (49.2 ft) cable set (2 pcs.) remote mounting with SONOKIT flowmeters	A5E02478541	
30 m (98.4 ft) cable set (2 pcs.) remote mounting with SONOKIT flowmeters	A5E02478751	

Sensor cables for FUS880 retrofitting systems (7ME3440)

Description	Article No.	
Coaxial cable with transducer connection		
for use in FUS880 and SONO 3300 sensors; with 0.3 m brown PTFE high temperature transducer part, max. 200 °C (392 °F) and black PVC for the remaining transmitter part, max. 70 °C (158 °F); cable impedance 75 Ω		
• 1 x 10 m (32.8 ft)	FDK:085L2400	
• 1 x 20 m (65.6 ft)	FDK:085L2401	
• 1 x 30 m (98.4 ft)	FDK:085L2402	
Transducer spare part set of two transducers with gaskets for STRANS FUS880 retrofitting systems	FDK:087H3007	

Flow Measurement

SITRANS F US InLine

Transmitter SITRANS FUS080/FUE080

Dimensional drawings

FUS080 transmitter IP67/NEMA 4X/6, wall mounting and compact mounting

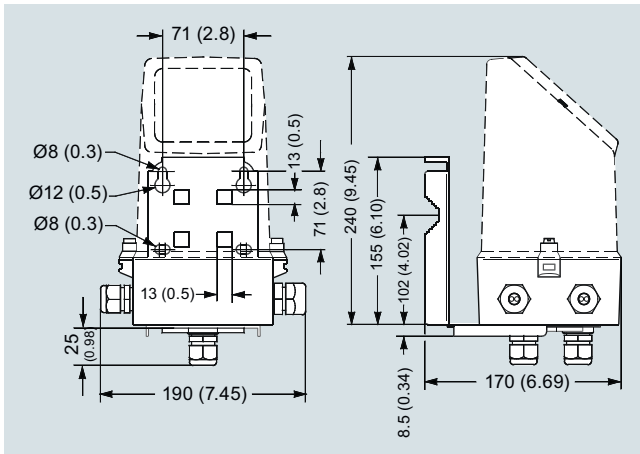

Transmitter wall mounted, dimensions in mm (inch)

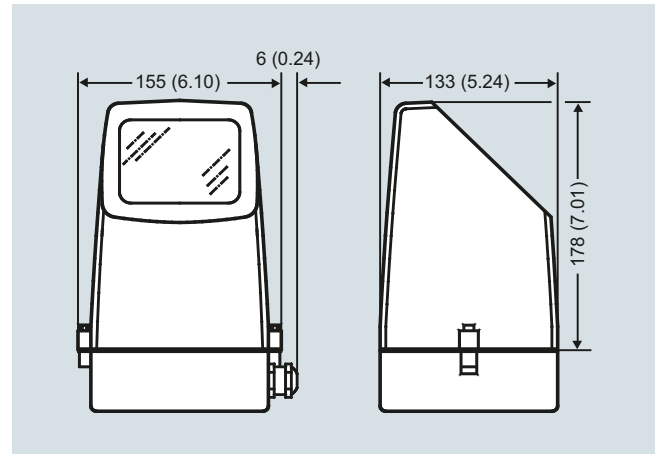

Transmitter compact mounted, dimensions in mm (inch)

Schematics

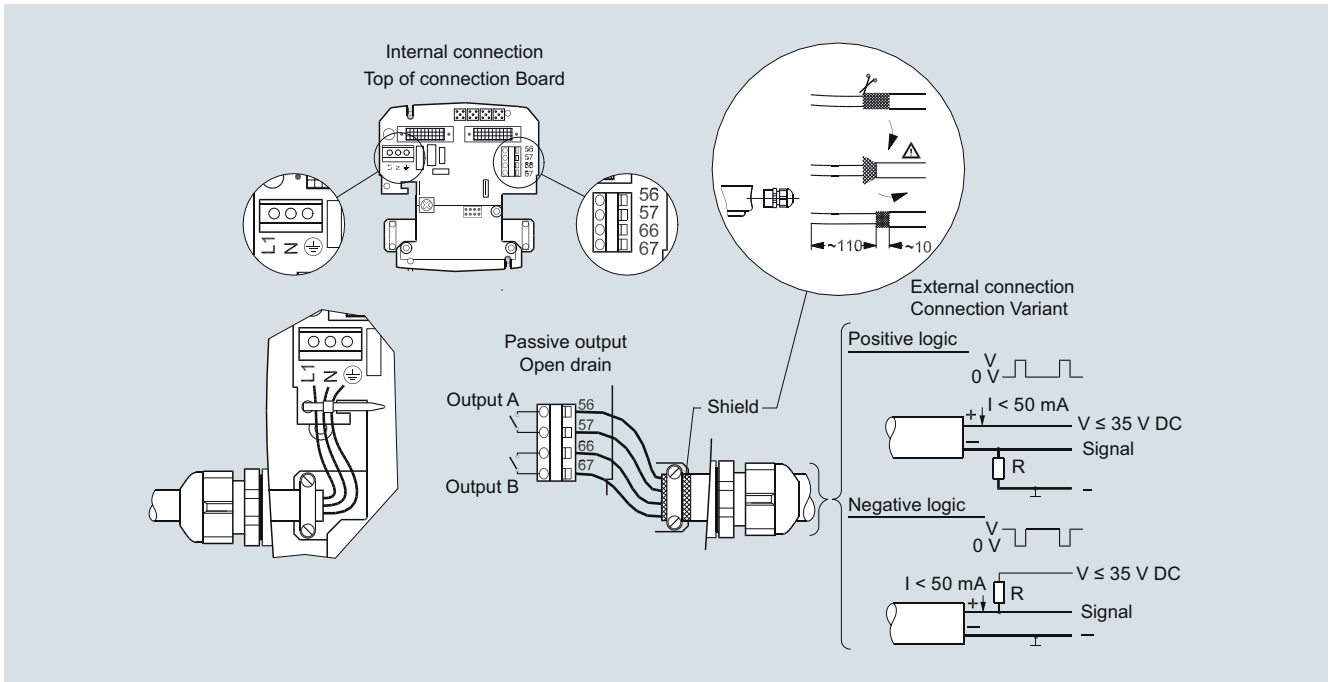

Electrical connection of SITRANS FUS080

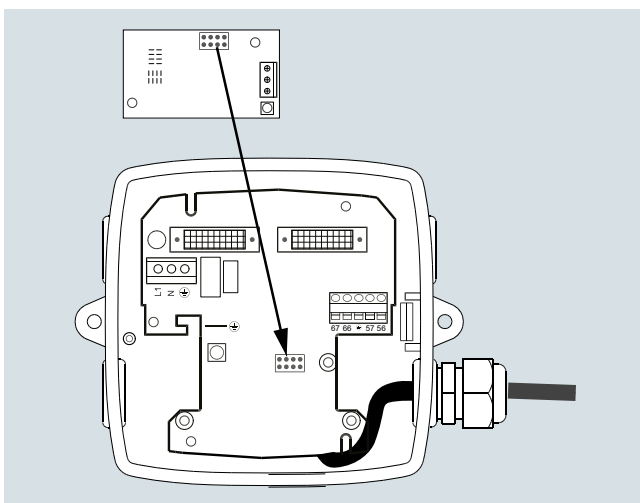

Analog module SITRANS FUS080

Flow Measurement

SITRANS F US Inline

Flowmeter SONO 3300/FUS060

Overview



The combination of SONO 3300 sensor and FUS060 transmitter is ideal for applications within the general industry. Measurements are independent of liquid temperature, density, pressure and conductivity. Transducers cannot be replaced.

Benefits

- Robust remote transmitter FUS060
- Robust design for industrial applications
- Measures all liquids less than 350 cSt, conductive or non-conductive
- No pressure drop
- Reliable and accurate flow measurements
- Long-time stability
- ATEX approval

Application

The main application for SONO 3300/FUS060 ultrasonic flowmeter is measurement of volume.

SONO 3300/FUS060 can be used for water and treated waste water, oil, hot water/cooling systems.

Design

The SONO 3300/FUS060 consists of a casted sensor (DN 50 to 80 (2" to 3")), welded pipes (DN 100 to 300 (4" to 12")) and a transmitter FUS060.

The transmitter can only be mounted separately.

The internal signal cables from transducers to sensor connection box are protected from an aggressive environment by stainless steel pipes.

Sensor installation

See system information.

Technical specifications

The transmitter related to this system is the SITRANS FUS060. Technical specifications to the FUS060 see page 3/247.

2-path sensor with flanges and inline transducers

Error in measurement	
Error in measurement at reference conditions	$v > 0.5 \dots 10 \text{ m/s}$, $< \pm 0.5 \%$ of rate ($v = \text{flow speed}$)
Max. flow velocity	10 m/s (32 ft/s)
Nominal size	
	DN 50, DN 65, DN 80, DN 100, DN 125, DN 150, DN 200, DN 250, DN 300 (2" ... 12")
Media temperature	Separate version: $-10 \dots +160 \text{ }^\circ\text{C}$ (14 ... 320 $^\circ\text{F}$)
Ambient temperature (sensor)	Separate version: $-20 \dots +60 \text{ }^\circ\text{C}$ (-4 ... +140 $^\circ\text{F}$) Storage: $-40 \dots +85 \text{ }^\circ\text{C}$ (-40 ... +185 $^\circ\text{F}$)
Enclosure	Standard version: IP67 (NEMA 4X/NEMA 6) ATEX version: As standard, but with ATEX approval (see below)
Process connections	
PN designated EN 1092-1, type 11 (B)	<ul style="list-style-type: none"> • DN 50 ... 300 (2" ... 12"), PN 40 • DN 100 ... 300 (4" ... 12"), PN 16 • DN 200 ... 300 (8" ... 12"), PN 10
Class designated EN 1759-1	<ul style="list-style-type: none"> • DN 50 ... 300 (2" ... 12"), class 150 • DN 50 ... 300 (2" ... 12"), class 300
Transducer	Inline version welded into pipe
Materials	
Pipe	<ul style="list-style-type: none"> • DN 50 ... 80 (2" ... 3"): Cast steel EN 1.1131-GS-15Mn5 • DN 100 ... 300 (4" ... 12"): Carbon steel EN 1.0345-P235GH
Flange	<ul style="list-style-type: none"> • DN 50 ... 300 (2" ... 12"): EN 1.0025-S235JRG2
Class	ASTM A105
Transducer	Stainless steel AISI 316 or similar

Certificates and approvals

Conformity certificate	The devices are supplied as standard with a Siemens Certificate of Conformity on DVD
Material certificate	Material certificate according to EN 10204-3.1 is optionally available
NDT examination report	Extended material certificate is available on special request (PVR)
Calibration report	A standard calibration report is shipped with each flowmeter.
Extended accredited ISO/IEC 17025 calibration certificates	Optionally available
Approvals	No custody transfer approvals
Ex approval	System ATEX approval for SONO 3300 with remote transmitter FUS060-Ex (ATEX II 2 G Ex dem [ia/ib] IIC T6/T4/T3 Gb) For Ex version the transducer cable length is restricted to 3 m (9.84 ft), in order to meet requirements.

The sensors are approved according to EU directive 2014/68/EU dated 27 June 2014 regarding fluid group 1, classified in category III. Design according to EN 13480 (PED Directive).

Coaxial cable between sensor SONO 3300 and transmitter FUS060

Standard Coaxial cable (75 Ω)	Coaxial cable with SMB straight plug on one end for the FUS060 connector
Outside diameter	Ø 5.8 mm
Length	3, 15, 30, 60, 90, 120 m (9.84, 49.21, 98.43, 196.85, 295.28, 393.70 ft) between sensor and transmitter
Material (outside jacket)	black PE
Ambient temperature	-10 ... +70 °C (14 ... 158 °F)
High temperature Coaxial cable (75 Ω)	Coaxial cable with SMB straight plug on one end for the FUS060 connector
Outside diameter	Ø 5.13 mm (first 0.3 m (0.98 ft) part to the transducer), Ø 5.8 mm (for remaining cable to the transmitter - with SMB plug at the end) and between these is a black hot melt junction Ø 16 mm (length 70 mm)
Length	3, 15, 30, 60, 90, 120 m (9.84, 49.21, 98.43, 196.85, 295.28, 393.70 ft) between sensor and transmitter (max. 3 m (9.84 ft)) transducer cable length for Ex area mounted transmitters)
Material (outside jacket)	Brown PTFE (0.3 m (0.98 ft) part) and black PE (for remaining cable)
Ambient temperature	-200 ... +200 °C (-328 ... +392 °F) (brown PTFE transducer part) and -10 ... +70 °C (14 ... 158 °F) (black PE for remaining transmitter cable part)



Flow Measurement

SITRANS F US Inline

Flowmeter SONO 3300/FUS060

Selection and Ordering data

Sensor SONO 3300 with transmitter FUS060 Article No. Order code
7ME3300-

Click on the Article No. for the online configuration in the PIA Life Cycle Portal.

Diameter	Qn setting [m ³ /h]	
DN 50 (2")	10	1 A
DN 50 (2")	26	1 B
DN 50 (2")	60	1 D
DN 65 (2½")	15	1 E
DN 65 (2½")	42	1 F
DN 65 (2½")	100	1 H
DN 80 (3")	20	1 J
DN 80 (3")	60	1 K
DN 80 (3")	150	1 M
DN 100 (4")	36	1 N
DN 100 (4")	100	1 P
DN 100 (4")	230	1 R
DN 125 (5")	50	1 S
DN 125 (5")	150	1 T
DN 125 (5")	360	1 V
DN 150 (6")	80	2 A
DN 150 (6")	220	2 B
DN 150 (6")	500	2 D
DN 200 (8")	120	2 E
DN 200 (8")	380	2 F
DN 200 (8")	900	2 H
DN 250 (10")	200	2 J
DN 250 (10")	600	2 K
DN 250 (10")	1400	2 M
DN 300 (12")	300	2 N
DN 300 (12")	850	2 P
DN 300 (12")	2200	2 R

Flange norm and pressure rating

(All sizes are not available in all pressure ratings)

EN 1092-1

PN 10 (DN 200 ... 300 (8" ... 12"))

PN 16 (DN 80 ... 300 (3" ... 12"))

PN 40 (DN 50 ... 300 (2" ... 12"))

ANSI B16.5

class 150 (DN 50 ... 300 (2" ... 12"))

class 300 (DN 50 ... 300 (2" ... 12"))

Sensor type (approval) and transmitter mounting

IP67 standard, remote transmitter

IP67 Ex-version (ATEX), remote transmitter

(Ex-version)

Cable gland entries in FUS060 and SONO 3300

Cable glands M20 in sensor and in transmitter M25/20/16 x 1.5

Transmitter version of SITRANS FUS060

IP65 (NEMA 4), 120/230 V AC

IP65 (NEMA 4), 24 V AC/DC

IP65 (NEMA 4), 24 V AC/DC, Ex-version (ATEX)

Selection and Ordering data

Sensor SONO 3300 with transmitter FUS060 Article No. Order code
7ME3300-

FUS060 output module

HART, 4 ... 20 mA, 1 pulse output, 1 relay

HART, Ex version, 4 ... 20 mA, 1 pulse output, 1 relay

PROFIBUS PA, 1 pulse/frequency

Transducer coaxial cable

4 x 3 m, max. 70 °C (158 °F), the only option for Ex i

4 x 15 m, max. 70 °C (158 °F)

4 x 30 m, high temp. max.200 °C (392 °F)

4 x 30 m, max. 70 °C (158 °F)

4 x 60 m, max. 70 °C (158 °F)

4 x 90 m, max. 70 °C (158 °F)

4 x 120 m, max. 70 °C (158 °F)

4 x 3 m, high temp. max. 200 °C (392 °F), the only option for Ex i

4 x 15 m, high temp. max. 200 °C (392 °F)

Selection and Ordering data

Order code

Additional information

Please add „-Z“ to Article No. and specify Order code(s) and plain text.

Calibration

Production calibration DN 50 ... DN 300 (with certificate, 2 x 3 points in 10 %, 25 % and 100 % Qn)

Included

Accredited Siemens ISO/IEC 17025 calibration for DN 50 to DN 200 with Qn as selected in Diameter. Calibration certificate: 2 x 5 points in 5 %, 10 %, 25 %, 50 % and 100 % Qn (max. flow 630 m³/h).

D20

Accredited Siemens ISO/IEC 17025 calibration for DN 200 to DN 300 with Qn as selected in Diameter. Calibration certificate: 2 x 5 points in 5 %, 10 %, 25 %, 50 % and 100 % Qn (max. flow 2000 m³/h).

D21

Material certificate

EN 10204-3.1

F10

Tag name plate

Stainless steel TAG plate (1 x 24 x 80 mm), wire fixed. Font size depends on text length: 8 mm for 1 ... 10 characters, 4 mm for 11 ... 20 characters (specify in plain text).

Y17



Please use online Product selector to get latest updates. Product selector link:

www.pia-portal.automation.siemens.com

Flowmeter SONO 3300 with FUS060 operating instructions, accessories and spare parts

Operating instructions

Description	Article No.
SITRANS FUS060	
• English	A5E01204521
• German	A5E02123845
SITRANS F US SONO 3300	
• English	A5E01365400
• German	A5E02690975

All literature is available to download for free, in a range of languages, at www.siemens.com/processinstrumentation/documentation

Accessories

Potting kit

Description	Article No.
Potting kit for terminal box of SONO 3200 transducers for IP68/NEMA 6P (not for Ex sensors)	FDK:085L2403



Cable connection boxes

(Optional for the connection of individually transducer cables with the FUS060 transducer cables)

Description	Article No.
Junction box for coaxial cable	
• IP65 metal box for 4 coaxial cables (2 pair)	FDK:085B1361



Spare parts

Cables for SONO 3300 with FUS060 (only as spare parts)

Description	Length m (ft)	Article No.
Coaxial cable for FUS060, (75 Ω, max. 70 °C (158 °F), black PVC) (2 pcs.)	3 (9.84)	A5E00875101
	15 (49.21)	A5E00861432
	30 (98.43)	A5E01278662
	60 (196.85)	A5E01278682
	90 (295.28)	A5E01278687
	120 (393.70)	A5E01278698
High temp. coaxial cable for FUS060; with 0.3 m brown PTFE high temp. transducer part (max. 200 °C (392 °F)) and black PVC transmitter part with SMB plug (max. 70 °C (158 °F)); impedance 75 Ω (2 pcs.)	3 (9.84)	A5E00875105
	15 (49.21)	A5E00861435
	30 (98.43)	A5E01196952



Cable glands (for the SONO 3300 terminal box) (only as spare parts)

Type	Material	Temperature range [°C (°F)]	Article No.
M20	Nickel-plated brass, 2x cables Ø 5 ... 6 mm (2 pcs.)	-25 ... +200 (-13 ... +392)	A5E02246329



Flow Measurement

SITRANS F US Inline

Flowmeter SONO 3300/FUS060

Description	Article No.	Description	Article No.
SONO 3300 terminal box lid, in stainless steel painted black (1 pc.)	FDK:085U1505	SONO 3300 stainless steel terminal box (1 pc.), M20 cable gland version, incl. lid in stainless steel (painted black) and gasket in EPDM	A5E00836867
Gasket for SONO 3300 terminal lid in EPDM (1 pc.)	FDK-085U1820	Coax cable connecting plate (1 pc.) for SONO 3300 terminal box and use with transmitter type FUS060	A5E02593568

Dimensional drawings

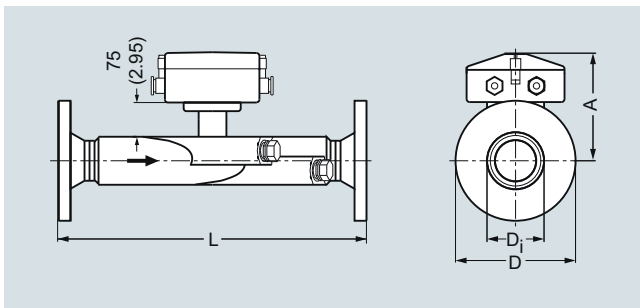

Sensor SONO 3300, dimensions in mm (inch)

DN	EN 1092-1																	
	PN 10						PN 16						PN 40					
	L ¹⁾		D		D _i		L ¹⁾		D		D _i		L ¹⁾		D		D _i	
	mm	inch	mm	inch	mm	inch	mm	inch	mm	inch	mm	inch	mm	inch	mm	inch	mm	inch
50													475	18.70	165	6.50	52.60	2.07
65													475	18.70	185	7.28	62.70	2.47
80							380	14.96	200	7.87	78.00	3.07	400	15.75	200	7.87	78.00	3.07
100							375	14.76	220	8.66	102.40	4.00	400	15.75	235	9.25	102.40	4.00
125							375	14.76	250	9.84	128.30	5.05	400	15.75	270	10.63	128.30	5.05
150							360	14.17	285	11.22	154.20	6.07	400	15.75	300	11.81	154.20	6.07
200	400	15.75	340	13.39	207.30	8.16	400	15.75	340	13.39	207.30	8.16	450	17.72	375	14.76	206.50	8.13
250	400	15.75	395	15.55	260.40	10.25	400	15.75	405	15.94	260.40	10.25	500	19.69	450	17.72	258.80	10.19
300	400	15.75	445	17.52	309.70	12.19	420	16.54	460	18.11	309.70	12.19	500	19.69	515	20.28	307.90	12.12

DN	ANSI												Weight ²⁾					
	150 lb						300 lb						EN and ANSI		EN		ANSI	
	L ¹⁾		D		D _i		L ¹⁾		D		D _i		A					
	mm	inch	mm	inch	mm	inch	mm	inch	mm	inch	mm	inch	mm	inch	kg	lb	kg	lb
50 mm/2"	510	20.08	152	5.98	52.6	2.07	520	20.47	165	6.50	52.6	2.07	180	7.09	14	30.9	17	37.5
65 mm/2½"	510	20.08	178	7.01	62.7	2.47	520	20.47	190	7.48	62.7	2.47	186	7.32	16	35.3	20	44
80 mm/3"	420	16.54	191	7.52	78.0	3.07	440	17.32	210	8.27	78.0	3.07	193	7.60	19	42	23	51
100 mm/4"	420	16.54	229	9.01	102.4	4.03	440	17.32	254	10	102.4	4.03	205	8.07	25	55	35	78
125 mm/5"	440	17.32	254	10.00	128.3	5.05	460	18.11	279	10.98	128.3	5.05	218	8.58	29	64	40	89
150 mm/6"	430	16.93	279	10.98	154.2	6.07	450	17.71	318	12.52	154.2	6.07	232	9.13	35	78	50	111
200 mm/8"	480	18.90	343	13.50	202.7	7.98	500	19.69	381	15	202.7	7.98	256	10.08	54	119	72	160
250 mm/10"	490	19.29	406	15.98	254.5	10.02	520	20.47	444	17.48	254.5	10.03	283	11.14	85	189	98	217
300 mm/12"	550	21.65	483	19.02	306.3	12.06	580	22.83	521	20.51	306.3	12.06	309	12.17	115	256	142	322

¹⁾ Length tolerance (mm): DN 50 ... 100 +2/-3, DN 125 ... 200 +3/-4, DN 250 ... 300 +4/-5

²⁾ Approximate weights without transmitter FUS060 - weight of FUS060 is 4.4 kg (9.7 lb)

Schematics

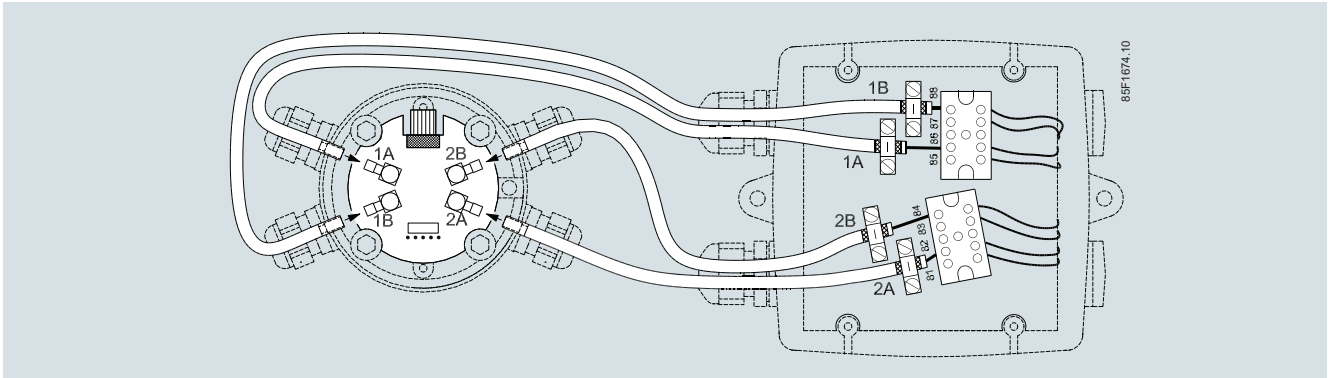

Electrical connection of SITRANS FUS060 and SONO 3300

Flow Measurement

SITRANS F US Inline

Flowmeter SONO 3100/FUS060

Overview



The combination of the SONO 3100 sensor and the FUS060 transmitter is ideal for applications where process shut-down is impossible during service and where there is a need for extreme high/low temperatures and pressures.

Transducers can be changed without interrupting operation. SONO 3100 can optionally be delivered as a 4-path solution for absolute best performance and accuracy.

Benefits

- Transducers can be replaced under pressure
- Measurement of all liquids less than 350 Cst, conductive or non-conductive
- No pressure drop
- Reliable and accurate flow measurements
- Long-time stability
- On request as special versions:
 - Special sensor material, e.g. Duplex, stainless steel
 - High/low temperature sensor version: +250 °C (+482 °F)/ -200 °C (-328 °F) sensors
 - Pressure rating 430 bar (6235 psi)
 - Special sensor sizes down to DN 25
 - 1-path or 2-path sensor technology

Application

The main application for SONO 3100 in combination with transmitter type FUS060 is to measure volume flow within:

- Petrochemical industry
- Power engineering
- Water and waste water
- Oil and liquefied gases

SITRANS FUS060 holds ATEX for hazardous areas, HART and PROFIBUS PA. SONO 3100 holds ATEX Ex approval.

Design

The SONO 3100 in combination with FUS060 consists of a SONO 3100 sensor, SONO 3200 transducers with O-rings or flanges depending on selection - and a FUS060 transmitter. SONO 3100 is basically supplied in a 2-path solution with flanges in sizes from DN 100 to DN 600 and without flanges in sizes from DN 100 to DN 300.

2 path standard, 1-path or 4-path special versions are available on request, depending on size (DN 25 to DN 1200).

SONO 3100 is as standard available in carbon steel from DN 100 to DN 600.

FUS060 is designed for remote wall mounting only.

Technical specifications

The transmitter related to this system is the SITRANS FUS060. Technical specifications to the FUS060 see page 3/247.

2-path sensor fitted with four SONO 3200 transducers

Error in measurement

Error in measurement at reference conditions $v > 0.5 \dots 10 \text{ m/s}$, $\pm 0.5 \%$ of rate (v =flow velocity)

Max flow velocity 10 m/s (32 ft/s)

Nominal size DN 100 ... 600 (4" ... 24")

Media temperature

- Standard -10 ... +200 °C (14 ... 392 °F)
- ATEX Ex d version -20 ... +180 °C (-4 ... +356 °F)
- ATEX Ex i version -10 ... +190 °C (14 ... 374 °F)
- Specials -200 °C (-328 °F) or up to 250 °C (482 °F)

Ambient temperature

- Standard and Ex-i version -20 ... +60 °C (-4 ... +140 °F)
- Ex d version -20 ... +180 °C (-4 ... +356 °F)

Enclosure

IP67 (NEMA 4X/6)/IP68 (NEMA 6P) and ATEX (see below)

Process connections

PN designated, EN 1092-1, type 11 (B)

Pipe material carbon steel

- DN 200 ... 600 (8" ... 24"), PN 10
- DN 100 ... 600 (4" ... 24"), PN 16
- DN 200 ... 600 (8" ... 24"), PN 25
- DN 100 ... 500 (4" ... 20"), PN 40

Class designated, EN 1759-1

Pipe material carbon steel

- DN 100 ... 600 (4" ... 24") Class 150
- DN 100 ... 300 (4" ... 12") Class 300

Without flanges (EN 10217), (weld-in version)

only in carbon steel

- DN 350 ... 600 (14" ... 24"), PN 10
- DN 100 ... 600 (4" ... 24"), PN 16
- DN 200 ... 600 (8" ... 24"), PN 25
- DN 100 ... 500 (4" ... 20"), PN 40

Transducer SONO 3200

O-ring or flange versions

Materials

Pipe

Steel EN 1.0345-P235GH

Flange

PN

EN 10025-S235JRG2, 1E1

Class

ASTM A105, 1,1

Transducer body

Stainless steel AISI 316 or similar

Transducer terminal house

Stainless steel AISI 316 or plastic PA 6.6

Flow Measurement

SITRANS F US Inline

Flowmeter SONO 3100/FUS060

Selection and Ordering data

SITRANS F US SONO 3100 sensor 2-path Article No. Order code
7ME3100-

Pipe and flange material

Carbon steel (DN 100 ... 1200) 1

Transducer type and approval

IP67 (NEMA 4X/6) PA housing, PN 40, O-ring, 50 mm, 100 °C (212 °F) (DN 100 ... 600) 1
 IP68 SS housing, PN 40, O-ring, 50 mm, 200 °C (392 °F) (DN 100 ... 600) 2
 IP68 SS housing, PN 40, O-ring, 50 mm, 180 °C (356 °F), Ex d ATEX approval (only with standard FUS060) (DN 100 ... 600) 3
 IP67 (NEMA 4X/6) PA housing, PN 40, flange, 88 mm, 100 °C (212 °F) (DN 100 ... 300) 4
 IP68 SS housing, PN 40, flange, 88 mm, 200 °C (392 °F) (DN 100 ... 300) 5
 IP68 SS housing, PN 40, flange, 88 mm, 180 °C (356 °F), Ex d ATEX approval (only with standard FUS060) (DN 100 ... 300) 6
 IP67 SS housing, PN 40, O-ring, 50 mm, 190 °C (374 °F), Ex i ATEX approval (only with FUS060 Ex-version) (DN 100 ... 600) 7
 IP67 SS housing, PN 40, flange, 88 mm, 190 °C (374 °F), Ex i ATEX approval (only with FUS060 Ex-version) (DN 100 ... 300) 8

Cable gland entries

Cable glands M20 in transducers and in transmitter M25/20/16 x 1.5 1
 Cable glands ½" NPT in transducers and in transmitter 2

Transmitter version of SITRANS FUS060

IP65 (NEMA 4), 120/230 V AC N
 IP65 (NEMA 4), 24 V AC/DC P
 IP65 (NEMA 4), 24 V AC/DC ATEX Ex version Q

FUS060 output module

HART, 1 pulse output, 1 relay B
 HART Ex, 1 pulse output, 1 relay C
 PROFIBUS PA, 1 pulse/frequency D

Transducer coaxial cable

4 x 3 m, max. 70 °C (158 °F), the only option for Ex i 0
 4 x 15 m, max. 70 °C (158 °F) 1
 4 x 30 m, high temp. max. 200 °C (392 °F) 2
 4 x 30 m, max. 70 °C (158 °F) 3
 4 x 60 m, max. 70 °C (158 °F) 4
 4 x 90 m, max. 70 °C (158 °F) 5
 4 x 120 m, max. 70 °C (158 °F) 6
 4 x 3 m, high temp. max. 200 °C (392 °F), the only option for Ex i 7
 4 x 15 m, high temp. max. 200 °C (392 °F) 8

- 1) Reduced Q value during calibration (Qn setting unchanged).
 2) For weld-in sensor versions according to EN 10217 (flangeless sensors 7ME3100-xxYxx-xxxx, Y = P, Q, R, S) the tube roundness shall be agreed via the PVR process (only if the factor of Du / Wxx > 100).

Selection and Ordering data

Order code

Additional information

Please add „-Z“ to Article No. and specify Order code(s) and plain text.

Calibration

Production calibration DN 100 ... DN 600 (with certificate)

Included

Accredited Siemens ISO/IEC 17025 calibration for DN 100 to DN 200 with Qn as selected in diameter. Calibration certificate: 2 x 5 points in 5 %, 10 %, 25 %, 50 % and 100 % Qn (max. flow 630 m³/h).

D20

Accredited Siemens ISO/IEC 17025 calibration for DN 200 to DN 600 with Qn as selected in diameter. Calibration certificate: 2 x 5 points in 5 %, 10 %, 25 %, 50 % and 100 % Qn (max. flow 2800 m³/h).

D21

Accredited Siemens ISO/IEC 17025 calibration for DN 400 to DN 600 with Qn as selected in diameter. Calibration certificate: 2 x 5 points in 5 %, 10 %, 25 %, 50 % and 100 % Qn (max. flow 8000 m³/h).

D22

Material certificate

EN 10204-3.1 F10
 EN 10204-3.1 and 100 % NDT on weldings, DN 100 ... DN 400 F11
 EN 10204-3.1 and 100 % NDT on weldings, DN 500 ... DN 600 F12

Pressure certificate

EN 10204-2.3 F21

Tag name plate

Stainless steel TAG plate (1 x 24 x 80 mm), wire fixed. Font size depends on text length: 8 mm for 1 ... 10 characters, 4 mm for 11 ... 20 characters (specify in plain text). Y17



Please use online Product selector to get latest updates. Product selector link:

www.pia-portal.automation.siemens.com

Flowmeter SONO 3100 with FUS060 operating instructions, accessories and spare parts

Operating instructions

Description	Article No.
SITRANS FUS060	
• English	A5E01204521
• German	A5E02123845
SITRANS F US SONO 3100	
• English	A5E00814513

All literature is available to download for free, in a range of languages, at www.siemens.com/processinstrumentation/documentation

Accessories

Description	Article No.
Potting kit for terminal box of SONO 3200 transducer for IP68/NEMA 6P (not for Ex sensors)	FDK:085L2403



Description	Transducer length	Article No.
Extraction tool for replacement of SONO 3200 O-ring transducers under pressure and for hot-tapping (working conditions: typically water, max. 40 bar and max. 60 °C (max. 580 psi and max. 140 °F))	50 mm (1.97") transducers	FDK:085B5331



Cable connection boxes
(For the connection of individually transducer cables with the FUS060 transducer cables)

Description	Article No.
Junction box for coaxial cable	
• IP65 metal box for 4 coaxial cables (2 pair)	FDK:085B1361
• IP65 EEx e plastic box for 4 coaxial cables (2 pair), no ATEX approval	FDK:085B1363

**Spare parts**

Transducer SONO 3200 spare parts, complete units

Type	Material	Gasket	Press. rating	Terminal housing	Approv.	Temp. range [°C (°F)]	Length mm (inch)	Article No.
O-ring	316 SS	O-ring	PN 40	Plastic, PA 6.6 M20		-20 ... +100 (-4 ... +212)	50 (1.97)	FDK:085B5453
O-ring	316 SS	O-ring	PN 40	316 SS M20		-20 ... +200 (-4 ... +392)	50 (1.97)	FDK:085B5450
O-ring	316 SS	O-ring	PN 40	316 SS M20	Ex d ¹⁾	-20 ... +180 (-4 ... +356)	50 (1.97)	FDK:085B5451
O-ring	316 SS	O-ring	PN 40	316 SS M20	Ex i ²⁾	-10 ... +190 (14 ... 374)	50 (1.97)	A5E00836448
O-ring	316 SS	O-ring	PN 40	Plastic, PA 6.6 ½" NPT		-20 ... +100 (-4 ... +212)	50 (1.97)	A5E00839472
O-ring	316 SS	O-ring	PN 40	316 SS ½" NPT		-20 ... +200 (-4 ... +392)	50 (1.97)	A5E00839431
Flange	316 SS	Graphite	PN 40	Plastic, PA 6.6 M20		-20 ... +100 (-4 ... +212)	88 (3.47)	FDK:085B5461
Flange	316 SS	Graphite	PN 40	316 SS M20		-20 ... +200 (-4 ... +392)	88 (3.47)	FDK:085B5462
Flange	316 SS	Graphite	PN 40	316 SS M20	Ex d ¹⁾	-20 ... +180 (-4 ... +356)	88 (3.47)	FDK:085B5463
Flange	316 SS	Graphite	PN 40	316 SS M20	Ex i ²⁾	-10 ... +190 (14 ... 374)	88 (3.47)	A5E00836465
Flange	316 SS	Graphite	PN 40	Plastic, PA 6.6 ½" NPT		-20 ... +100 (-4 ... +212)	88 (3.47)	A5E00839479
Flange	316 SS	Graphite	PN 40	316 SS ½" NPT		-20 ... +200 (-4 ... +392)	88 (3.47)	A5E00839440
Flange	316 SS	Copper ring	PN 40	316 SS PG13.5 (cryogenic version)		-200 ... +100 (-328 ... +212)	88 (3.47)	FDK:085B5416
Flat flange	316 SS	Flat gasket	PN 40	316 SS M20 (cryogenic version)		-200 ... +100 (-328 ... +212)	88 (3.47)	A5E02593524

¹⁾ ATEX (Ex) IIC 2G Ex d IIC T3-T6 Gb

²⁾ For systems with FUS060 ATEX IIC 2G Ex dem [ia/ib] T6/T4/T3

Flow Measurement

SITRANS F US Inline

Flowmeter SONO 3100/FUS060

Terminal housing for SONO 3200 sensor

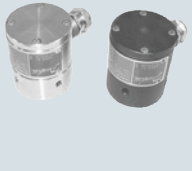
Type	Pressure rating	Material	Temp. range [°C (°F)]	Article No.	
Terminal housing (M20 cable gland)	N/A	PA 6.6	-20 ... +100 (-4 ... +212)	FDK:085B5501	
Terminal housing (M20 cable gland)	N/A	ASTM 316	-20 ... +200 (-4 ... +392)	FDK:085B5504	
Terminal housing (1/2" NPT cable gland)	N/A	PA 6.6	-20 ... +100 (-4 ... +212)	A5E00839460	
Terminal housing (1/2" NPT cable gland)	N/A	ASTM 316	-20 ... +200 (-4 ... +392)	A5E00839427	
Ex d ¹⁾ terminal housing (M20 cable gland)	N/A	ASTM 316	-20 ... +180 (-4 ... +356)	FDK:085B5505	
Ex i ²⁾ terminal housing (M20 cable gland)	N/A	ASTM 316	-10 ... +190 (14 ... 374)	A5E00835255	

1) ATEX (Ex) IIC 2G EEx d IIC T3 ... T6

2) For systems with FUS060 ATEX IIC 2G Ex dem [ia/ib] T6/T4/T3



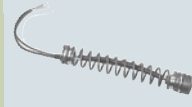

SONO 3200 spare parts, transducer body without terminal housing, including insert

Type	Material	Gasket	Pressure rating	Temp. range [°C (°F)]	Length mm (inch)	Article No.	
O-ring	316 SS	O-ring	PN 40	-20 ... +200 (-4 ... +392)	50 (1.97)	FDK:085B1405	
Flange	316 SS	Graphite	PN 40	-20 ... +200 (-4 ... +392)	88 (3.47)	FDK:085B1464	

SONO 3200 spare parts, transducer insert

Type	Temp. range [°C (°F)]	Length mm (inch)	Article No.	
Insert	-20 ... +200 (-4 ... +392)	50 (1.97)	FDK:085B1411	
Insert	-20 ... +200 (-4 ... +392)	88 (3.47)	FDK:085B1459	

Transducer SONO 3200 gaskets

Type	Pressure rating	Material	Temperature range [°C (°F)]	Article No.	
Gasket O-ring (3 pcs. for o-ring transducers)	PN 40	FKM	-20 ... +200 (-4 ... +392)	FDK:085B1089	
Gasket flange	PN 40/160	Graphite	-20 ... +200 (-4 ... +392)	FDK:085B1080	
Gasket and 12 mm (0.47") bolts and nuts for flange transducers (4 pcs.)	PN 40	AISI 316 or equal	-20 ... +200 (-4 ... +392)	FDK:085B1083	
Gasket and 16 mm (0.63") bolts and nuts for flange transducers (4 pcs.)	PN 160	Graphite, 316 SS	-20 ... +200 (-4 ... +392)	FDK:085B1084	
Gasket for cryogenics transducer with flat flange (2 pcs.)	PN 40	Graphite/metal composite	-200 ... +100 (-328 ... +212)	A5E02593522	

SONO 3200 cable glands

Type/description	Temperature range [°C (°F)]	Appr.	Article No.	
black PA plastic, cable Ø 5 ... 13 mm (1 pc.)	-20 ... 100 (-4 ... +212)		A5E02246304	
½" NPT gray PA plastic, cable Ø 5 ... 9 mm (1 pc.)	-20 ... 100 (-4 ... +212)		A5E02246309	
½" NPT chrome-plated brass, cable Ø 5 ... 9 mm (1 pc.)	-40 ... 100 (-40 ... +212)		A5E02246258	
M20 stainless steel, cable Ø 4 ... 6 mm (1 pc.)	-25 ... 200 (-13 ... +392)	Ex i	A5E02246194	
M20 Stainless steel, cable Ø 5 ... 8 mm (1 pc.)	-60 ... 180 (-76 ... +356)	Ex d	A5E02246311	

Cables for SONO 3100 with FUS060

Description	Length m (ft)	Article No.	
Coaxial cable for FUS060, (75 Ω, max. 70 °C (158 °F), black PVC) (2 pcs.)	3 (9.84)	A5E00875101	
	15 (49.21)	A5E00861432	
	30 (98.43)	A5E01278662	
	60 (196.85)	A5E01278682	
	90 (295.28)	A5E01278687	
High temp. coaxial cable for FUS060; with 0.3 m brown PTFE high temp. transducer part, max. 200 °C (392 °F) and black PVC for remaining transmitter part with SMB plug, max. 70 °C (158 °F); (impedance 75 Ω) (2 pcs.)	3 (9.84)	A5E00875105	
	15 (49.21)	A5E00861435	
	30 (98.43)	A5E01196952	
SITRANS F US special coaxial cable sets for low temperature cryogenic systems, with SMB-plug for transmitter SITRANS FUS060, PTFE material, temp. -200 ... +200 °C (-328 ... +392 °F), impedance 75 Ω (2 pcs.)	10 (32.84)	A5E02085593	
	15 (49.21)	A5E03262088	
	30 (98.43)	A5E02085644	
	40 (131.23)	A5E02085649	

Schematics

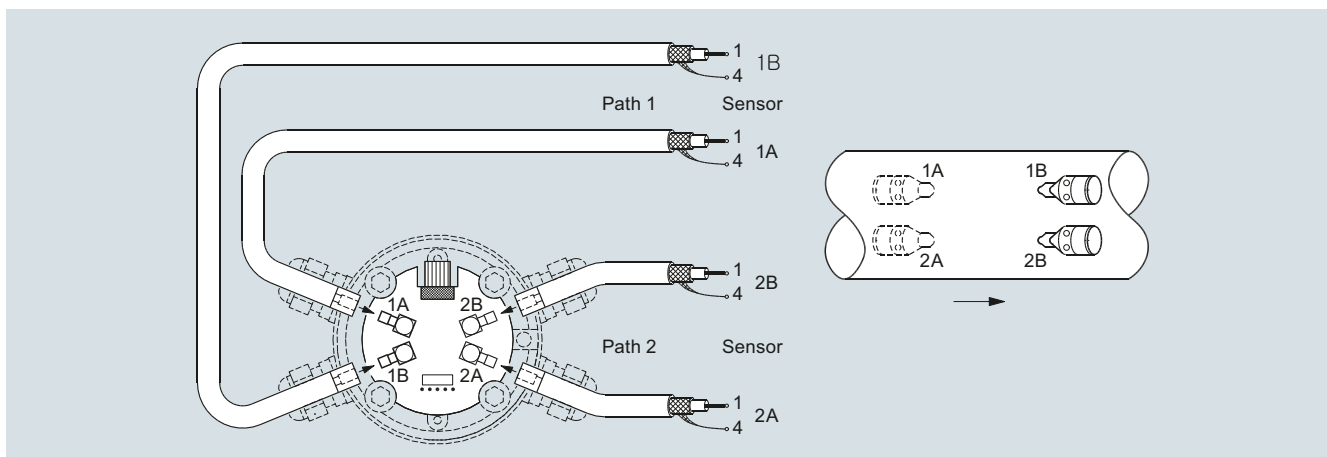

Electrical connection of SITRANS FUS060 and SONO 3100

Flow Measurement

SITRANS F US Inline

Flowmeter SONO 3100/FUS060

Dimensional drawings of sensor SONO 3100

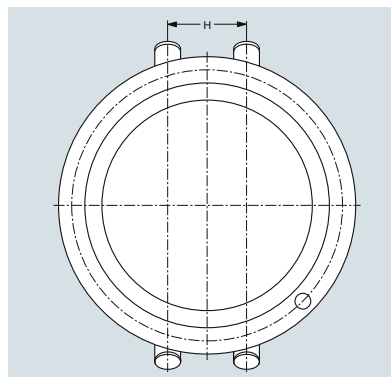
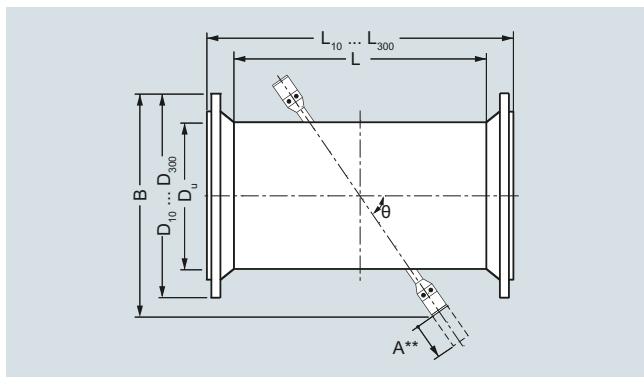

Sensor SONO 3100 with EN norm

DN	DU [mm]	L ^{1) 4)} [mm]	B ⁵⁾ [mm]	θ [°]	H [mm]	PN 10			PN 16			PN 25			PN 40		
						W _{min} ²⁾ [mm]	D ₁₀ [mm]	L ₁₀ ¹⁾ [mm]	W _{min} ²⁾ [mm]	D ₁₆ [mm]	L ₁₆ ¹⁾ [mm]	W _{min} ²⁾ [mm]	D ₂₅ [mm]	L ₂₅ ¹⁾ [mm]	W _{min} ²⁾ [mm]	D ₄₀ [mm]	L ₄₀ ¹⁾ [mm]
100	114.3	860	305	45 ³⁾	42.8	-	-	-	3.6	220	960	-	-	-	3.6	235	990
125	139.7	862	325	45 ³⁾	64.5	-	-	-	4.0	250	970	-	-	-	4.0	270	990
150	168.3	862	350	45 ³⁾	78.1	-	-	-	4.5	285	970	-	-	-	4.5	300	1010
200	219.1	668	430	45 ³⁾	102.1	6.3	340	790	6.3	340	790	6.3	360	820	6.3	375	840
250	273.0	714	480	45 ³⁾	127.6	6.3	395	850	6.3	405	850	7.1	425	890	7.1	450	920
300	323.9	607	525	45 ³⁾	151.8	7.1	445	740	7.1	460	760	8.0	485	790	8.0	515	830
350	355.6	639	550	45 ³⁾	166.4	8.0	505	770	8.0	520	800	8.0	555	840	8.8	580	880
400	406.4	703	600	45 ³⁾	191.3	8.0	565	850	8.0	580	875	8.8	620	925	11.1	660	975
500	508.0	797	690	45 ³⁾	241.1	7.1	670	950	8.0	715	980	10.0	730	1050	14.2	755	1080
600	610.0	912	830	60	294.8	7.1	780	1075	8.8	840	1105	11.0	845	1165	-	-	-

¹⁾ Length tolerance (mm): DN 100 +2/-3, DN 125 ... 200 +3/-4, DN 250 ... 400 +4/-5, DN 500 ... 600 +5/-6

²⁾ Wall thickness for pressure rates PN 6 ... 40. For weld-in sensor versions according EN10217 (flangeless sensors 7ME3100-xxYxx-xxxx, Y=P, Q, R, S) the tube roundness shall be agreed via the PVR process (only if the factor of Du/Wxx > 100).
W_{min} wall thickness are min. values. The delivered sensor can have larger wall thicknesses to meet the selected pressure rate. Any specific required wall thickness must be ordered as PVR.

³⁾ For all sensors with flange transducers path angle are 60°

⁴⁾ L is the length of sensor versions without flanges (weld-in version) For weld-in sensor versions according to EN 10217 (flangeless sensors 7ME3100-xxYxx-xxxx, Y = P, Q, R, S) the tube roundness shall be agreed via the PVR process (only if the factor of Du/Wxx > 100).

⁵⁾ B dimension value is an approximate information and may differ a little by flange pressure rate.

A**) Space required for replacement of transducer min. 230 mm (9.1 inch). For replacement with special tool (extraction tool) see more information on page 3/271.

SONO 3100, 2-path

Nominal diam. DN	Flange type - Weight [kg (lb)]			
	PN 10	PN 16	PN 25	PN 40
100 (4")	-	32 (70.5)	-	35 (77.2)
125 (5")	-	38 (83.8)	-	44 (97.0)
150 (6")	-	45 (99.2)	-	52 (114.6)
200 (8")	59 (130.0)	58 (127.9)	70 (154.3)	79 (174.2)
250 (10")	73 (161.0)	75 (163.3)	96 (211.6)	117 (257.9)
300 (12")	83 (183.0)	92 (202.8)	114 (251.3)	151 (332.9)
350 (14")	98 (216.0)	113 (249.1)	145 (322.9)	191 (421.1)
400 (16")	119 (262.4)	141 (310.9)	191 (421.1)	275 (606.3)
500 (20")	153 (337.3)	207 (456.4)	284 (626.0)	379 (836.0)
600 (24")	193 (425.5)	276 (608.5)	363 (800.3)	-

Weight of system incl. process flanges and standard O-ring transducers. For sensors with flange transducer please add approx. 10 kg (22.05 lb). For SS terminal housings instead of the standard PA housing add approx. 5 kg (11.03 lb).

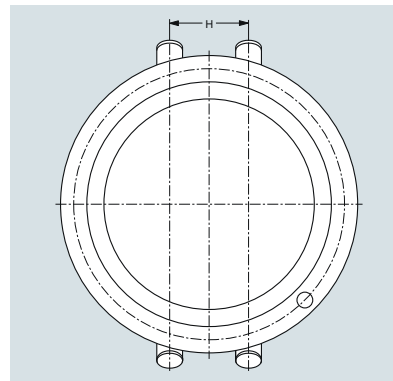
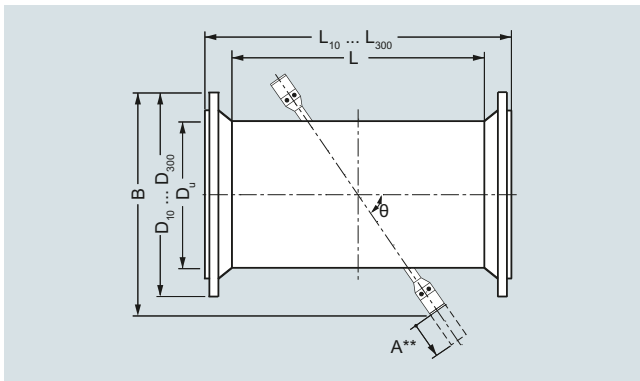

Sensor SONO 3100 with ANSI norm

Size (DN)	D _U	L ^{1) 4)}	B ⁵⁾	θ	H	Class 150			Class 300		
						W _{min} ²⁾	D ₁₅₀	L ₁₅₀ ¹⁾	W _{min} ²⁾	D ₃₀₀	L ₃₀₀ ¹⁾
inch (mm)	[inch]	[inch]	[inch]	[°]	[inch]	[inch]	[inch]	[inch]	[inch]	[inch]	[inch]
4 (100)	4.50	33.86	12.01	45 ³⁾	1.69	0.14	9.00	39.86	0.25	10.00	40.62
5 (125)	5.50	33.94	12.80	45 ³⁾	2.54	0.15	10.00	40.94	0.27	11.00	41.70
6 (150)	6.63	33.94	13.78	45 ³⁾	3.07	0.16	11.00	40.94	0.30	12.50	41.70
8 (200)	8.63	26.30	16.93	45 ³⁾	4.02	0.16	13.50	34.30	0.29	15.00	35.06
10 (250)	10.75	28.11	18.90	45 ³⁾	5.02	0.18	16.00	36.11	0.34	17.50	37.35
12 (300)	12.75	23.90	20.67	45 ³⁾	5.98	0.20	19.00	32.90	0.39	20.50	34.14
14 (350)	14.00	25.16	21.65	45 ³⁾	6.55	0.21	21.00	35.16	-	-	-
16 (400)	16.00	27.68	23.62	45 ³⁾	7.53	0.22	23.50	33.74	-	-	-
20 (500)	20.00	31.38	27.17	45 ³⁾	9.49	0.26	27.50	42.76	-	-	-
24 (600)	24.00	35.91	32.68	60	11.61	0.30	32.00	47.91	-	-	-

¹⁾ Length tolerance (mm): 4" +0.08"/-0.12" (+2/-3mm), 5" ... 8" +0.12"/-0.16" (+3/-4mm), 10" to 16" +0.16"/-0.20" (+4/-5mm), 20" ... 24" +0.20"/-0.24" (+5/-6mm)

²⁾ Minimum wall thickness for pressure rates Class 150 or Class 300. For weld-in sensor versions according to EN 10217 (flangeless sensors 7ME3100-xxYxx-xxxx, Y = P, Q, R, S) the tube roundness shall be agreed via the PVR process (only if the factor of D_U/W_{xx} > 100). W_{min} wall thickness are min. values. The delivered sensor can have larger wall thicknesses to meet the selected pressure rate. Any specific required wall thickness must be ordered as PVR.

³⁾ For all sensors with flange transducers path angle are 60°

⁴⁾ L is the length of sensor versions without flanges (weld-in version)

For weld-in sensor versions according to EN 10217 (flangeless sensors 7ME3100-xxYxx-xxxx, Y = P, Q, R, S) the tube roundness shall be agreed via the PVR process (only if the factor of D_U/W_{xx} > 100).

⁵⁾ B dimension value is an approximate information and may differ a little by flange pressure rate.

A**) Space required for replacement of transducer min. 230 mm (9.1 inch). For replacement with special tool (extraction tool) see more information in „Sensor SONO 3100 accessories and spare parts“ on page 3/271.

Flow Measurement

SITRANS F US Inline

Flowmeter SONO 3100/FUS060

Approximate weights for SONO 3100 sensor with ANSI B16.5 flanges

Nominal diameter		Weight [kg (lb)] ¹⁾			
DN	DN	CL150		CL300	
[inch]	[mm]	[kg]	[lb]	[kg]	[lb]
4	100	32	70.5	35	77.2
5	125	38	83.8	44	97.0
6	150	45	99.2	52	114.6
8	200	58	127.9	79	174.2
10	250	75	165.3	117	257.9
12	300	92	202.8	151	332.9
14	350	113	249.1	-	-
16	400	141	310.9	-	-
20	500	207	456.4	-	-
24	600	276	608.5	-	-

¹⁾ Weight of system incl. process flanges and standard O-ring transducers. For sensors with flange transducer please add approx. 10 kg (22.05 lb). For SS terminal housings instead of the standard PA housing add approx. 5 kg (11.03 lb).

Overview



SONOKIT is a transit time based ultrasonic flowmeter for retrofitting on existing pipelines.

The kit offers all necessary parts and special tools to make the installation as 1-path or 2-path flowmeter.

The set is made for installation on empty pipes or pipes under pressure without process shut-down (hot-tap).

Please contact Siemens for further information on hot-tap tools and instructions.

SONOKIT has inline transducers (in contact with media) which assure superior accuracy and performance.

Benefits

- Cost-effective solution – contains all the necessary components for retrofitting
- SONOKIT is easy to install in pipeline sizes DN 200 to DN 3000 (8" to 120") 1-path DN 100 to DN 2400 (4" to 96").
- No bypass installation necessary – withstands pressures up to 40 bar (580 psi) and media temperatures between -20 °C and +200 °C (-4 °F and +392 °F)
- High accuracy – the bigger the pipe, the more accurate the result
- Solid construction and no moving parts for a 100 % maintenance and obstruction-free flowmeter
- The SONOKIT comes with transducers in IP68 enclosure
- Available in a robust version that can be buried and withstands constant flooding
- Inline transducers assure superior accuracy and performance
- Automatic calculation of the calibration factor when pipe geometry data are entered in the transmitter
- FUS060 transmitter versions with HART or PROFIBUS PA
- FUS080 transmitter, battery or mains-powered

Application

- Raw water intake for water treatment plants
- Water distribution systems
- Irrigation systems
- Power generation (energy and water)
- District heating plants
- Cooling water plants within the industry and in power stations
- Systems within the oil and refinery business
- Sewage treatment plants
- Plants transporting non-conductive liquids

Design

The SONOKIT package box contains all necessary parts to build an ultrasonic flowmeter on existing pipes depending on choices at ordering:

- Papers to wrap around pipes for alignment of sensors
- Transducer alignment tools
- Mounting plates, transducer holders and SONO 3200 transducers
- Transducer cables
- SITRANS FUS060 or FUS080 transmitter for wall mounting
- 4-path version (up to DN 1500 (60")) is available on special request (PVR)

Technical specifications

The transmitter related to this system is the SITRANS FUS080 or FUS060.

Technical specifications to the FUS060 see page 3/247 and to FUS080 see page 3/253.

Accuracy

Typical, depending on accuracy of measurements of installation

- 2-path: $\pm (0.5 \dots 1.5 \%)$
- 1-path: $\pm (1 \dots 3 \%)$

Note:

Accuracy depends on the accuracy of the measurements taken at location. This means that inaccurate measurements of angles, distance between transducers, wall thickness and pipe diameter have a direct effect on the accuracy. Values measured are entered into the memory of the FUS060 or FUS080 transmitter.

Requirements for pipes

Size	FUS060: DN 100 ... DN 3000 (4" ... 120") FUS080: DN 100 ... DN 1200 (4" ... 48")
Line pressure	max. 40 bar (580 psi)
Media temperature	
• Standard	-10 ... +200 °C (14 ... 392 °F)
• ATEX Ex d version	-20 ... +180 °C (-4 ... +356 °F)
• ATEX Ex i version	-10 ... +190 °C (14 ... 374 °F)
Ambient temperature (sensor)	
• Standard and Ex-i version	-20 ... +60 °C (-4 ... +140 °F)
• Ex d version	-20 ... +180 °C (-4 ... +356 °F)
Transducer enclosure/ approvals/certificates	
Standard version	IP67 (NEMA 6)/IP68 (NEMA 6P)
Ex approval	System ATEX approval for SONO 3200 Ex i transducers together with transmitter FUS060-Ex: ATEX II 2 G Ex dem [ia/ib] IIC T6/T4/T3 Gb or ATEX II 2G Ex d IIC T3-T6 Gb with SONO 3200 Ex d transducers (for standard FUS060 transmitter, installed outside of Ex zone)
Material certificates	EN 10204-3.1 material certificate on transducer mounting parts
Transducer materials	
Terminal housing	Standard version: PA 6.6, 100 °C (212 °F) or stainless steel AISI 316, 200 °C (392 °F)
Transducer body	Standard version: Stainless steel AISI 316, 200 °C (392 °F)

Flow Measurement

SITRANS F US Inline

Flowmeter SONOKIT (with FUS060 or FUS080)

Materials of existing pipeline

Steel	Transducer holder: EN 10273 or EN 10216 (P235GH) Mounting plates ¹⁾ : EN 10273 or EN 10216 (P235GH)
Concrete	Transducer holder: Stainless steel AISI 316 or similar Mounting plates ¹⁾ : (not included)
Stainless steel	Transducer holder: Stainless steel AISI 316 or similar Mounting plates ¹⁾ : Stainless steel AISI 316 or similar

Pipe wall thickness

Steel pipe (AISI 316 and St. 37.2 or corresponding material)	Transducer and holder available in length $L = 160$, allowing a pipe wall thickness up to 20 mm (0.79")
Concrete pipe	Transducer and holder available in length $L = 230$, allowing a pipe wall thickness up to 200 mm (7.9") and pipe sizes \geq DN 600

Dimension of the package box
(L x W x H, approx.)

856 x 390 x 344 mm
(33.7" x 15.4" x 13.5")

Weight example of a package
(standard 2-path with FUS060)

approx. 53 kg (116.8 lb)

Certificates and approvals

Conformity certificate

The devices are supplied as standard with a Siemens Certificate of Conformity on a DVD

Material certificate

Material certificate for the transducer parts according to EN 10204-3.1 is optionally available

Approvals

No custody transfer approvals

Information on PED approval:

The SONOKIT includes the pipe mounting parts only and therefore it cannot be PED-approved. After the installation, all installation-related activities (welding, pressure test etc.) are the responsibility of the customer.

¹⁾ Mounting plates are only included for empty pipe installation types (refer to selection "A"). For hot tap mounting the mounting plates are not included (refer to selection "B").

Installation requirements

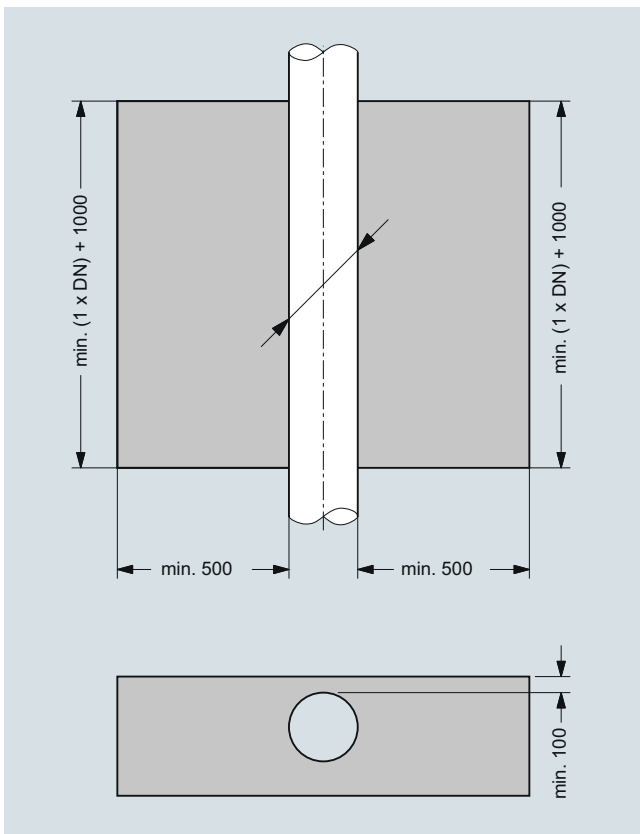

The space requirements (in mm) around the pipe for retrofitting a SITRANS F US ultrasonic flowmeter type SONOKIT are given below in mm:

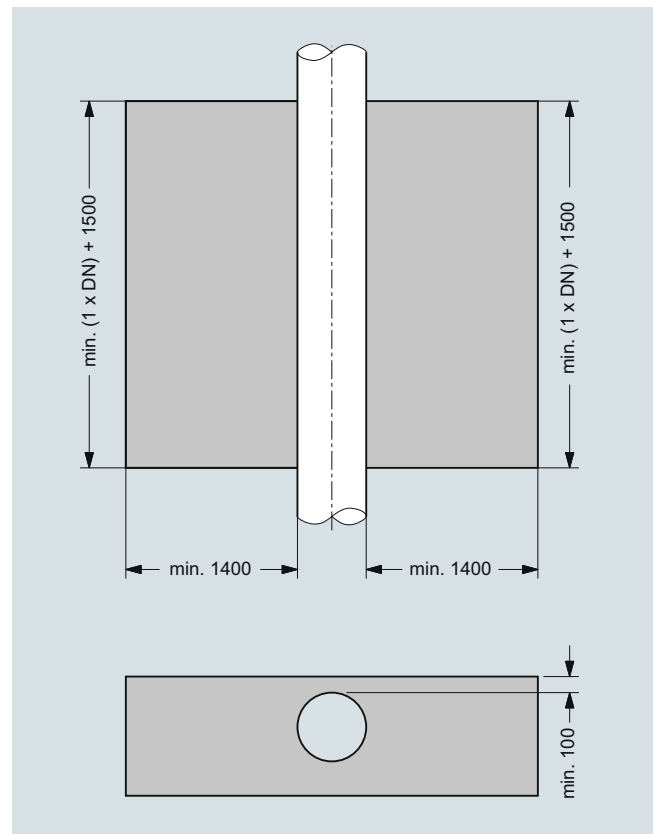

Empty pipe installation

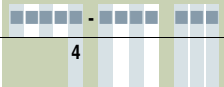

Hot-tap installation

Selection and Ordering data		Article No.	Ord. code	Selection and Ordering data		Article No.	Ord. code
SITRANS F US SONOKIT		7ME3210-		SITRANS F US SONOKIT		7ME3210-	
1-path sensor				1-path sensor			
							
 Click on the Article No. for the online configuration in the PIA Life Cycle Portal.							
Diameter	Qn setting [m³/h]						
DN 100 (4")	100	1 P		IP68 SS housing, Sylgard potting kit, PN 40, O-ring, 200 °C (392 °F), no approval		4	
DN 125 (5")	150	1 T		IP67 SS housing, PN 40, O-ring, 190 °C (374 °F), Ex i type, ATEX approval (only with FUS060 Ex)		5	
DN 150 (6")	220	2 B		Cable gland entries			
DN 200 (8")	380	2 F		Cable glands M20 in transducers and in transmitter M25/20/16 x 1.5 (FUS080 only M20)		1	
DN 250 (10")	600	2 K		Cable glands ½" NPT in transducers and in transmitter (only with FUS060)		2	
DN 300 (12")	850	2 P		Transmitter version of SITRANS FUS060 (only DN 100 ... 2400 (4" ... 96"))			
DN 350 (14")	1000	2 T		IP65 (NEMA 4), 120/230 V AC		N	
DN 400 (16")	1300	3 B		IP65 (NEMA 4), 24 V AC/DC		P	
DN 450 (18")	1700	3 F		IP65 (NEMA 4), 24 V AC/DC Ex version		Q	
DN 500 (20")	2200	3 K		Transmitter version of SITRANS FUS080 (only DN 100 ... 1200 (4" ... 48"))			
DN 550 (22")	2600	3 P		PDM software tool and IrDA-adapter, which are needed for settings update, to be ordered separately, see FUS080 accessories			
DN 600 (24")	3200	3 T		IP67/NEMA 4X/6 115 ... 230 V AC		U	
DN 650 (26")	3600	4 B		IP67/NEMA 4X/6 3.6 V battery version, incl. dual battery pack		V	
DN 700 (28")	4200	4 F		IP67/NEMA 4X/6 115 ... 230 V AC, incl. 3.6 V single battery backup		W	
DN 750 (30")	4800	4 K		IP67/NEMA 4X/6 3.6 V battery version (no battery pack included) ²⁾		X	
DN 800 (32")	5500	4 P		Transmitter output module			
DN 900 (36")	7500	5 B		Transmitter SITRANS FUS080:			
DN 1000 (40")	9000	5 K		Pulse and/or alarm output (standard for FUS080).		A	
DN 1100 (44")	10000	5 P		Transmitter SITRANS FUS060:			
DN 1200 (48")	13200	5 T		HART, 1 pulse output, 1 relay		B	
Only for FUS060				HART Ex version, 1 pulse output, 1 relay		C	
DN 1300 (52")	14000	6 A		PROFIBUS PA, 1 pulse/frequency		D	
DN 1400 (56")	16800	6 C		Transducer coaxial cables (with FUS080 only, 15 and 30 m, 70°C (158 °F) cable types)			
DN 1500 (60")	19000	6 E		2 x 3 m, max. 70 °C (158 °F), the only option for Ex i		0	
DN 1600 (64")	22800	6 G		2 x 15 m, max. 70 °C (158 °F)		1	
DN 1700 (68")	25000	6 J		2 x 30 m, high temp. max. 200 °C (392 °F)		2	
DN 1800 (72")	27600	6 L		2 x 30 m, max. 70 °C (158 °F)		3	
DN 1900 (76")	31000	6 N		2 x 60 m, max. 70 °C (158 °F)		4	
DN 2000 (80")	36000	6 Q		2 x 90 m, max. 70 °C (158 °F)		5	
DN 2100 (84")	37000	6 S		2 x 120 m, max. 70 °C (158 °F)		6	
DN 2200 (88")	42000	6 U		2 x 3 m, high temp. max. 200 °C (392 °F), the only option for Ex i		7	
DN 2300 (92")	45000	6 W		2 x 15 m, high temp. max. 200 °C (392 °F)		8	
DN 2400 (96")	51000	7 A		Special version (add Order code):			
Installation method¹⁾				No transducer cable, cable length 2 x 3 m, the only option for Ex i		9	R 0 A
Empty pipe (incl. transducer holder and mounting plates). Alignment rods and tools must be ordered as accessories.		A		No transducer cable, cable length 2 x 15 m		9	R 0 B
Hot tap, mounting under pressure (mounting plates not incl.). Special mounting tools to be ordered separately.		B		No transducer cable, cable length 2 x 30 m		9	R 0 C
Transducer holder				No transducer cable, cable length 2 x 60 m		9	R 0 D
Carbon steel, length = 160 mm, mounting plates in carbon steel		1		No transducer cable, cable length 2 x 90 m		9	R 0 E
Stainless steel, length = 160 mm, mounting plates in stainless steel		2		No transducer cable, cable length 2 x 120 m		9	R 0 F
Stainless steel, length = 230 mm, for concrete pipe (DN 600 ... DN 2400)		3					
Transducer type and approval							
IP67 (NEMA 4X/6) PA housing, PN 40, O-ring, 100 °C (212 °F), no approval		1					
IP68 SS housing, PN 40, O-ring, 180 °C (356 °F), Ex d, ATEX approval (only with standard FUS060)		2					
IP68 PA housing, Sylgard potting kit, PN 40, O-ring, 100 °C (212 °F), no approval		3					

1) Mounting tools must be ordered separately as "-Z"-options.

2) Lithium batteries are subject to special transportation regulations according to United Nations "Regulation of Dangerous Goods, UN 3090 and UN 3091". Special transport documentation is required to observe these regulations. This may influence both transport time and costs."

Flow Measurement

SITRANS F US Inline

Flowmeter SONOKIT (with FUS060 or FUS080)

Selection and Ordering data	Order code
Additional information	
Please add „-Z“ to Article No. and specify Order code(s) and plain text.	
<u>Material certificate</u>	
EN 10204-3.1, transducer body material	F30
EN 10204-3.1, transducer holder material	F31
EN 10204-3.1, mounting plate material	F32
<u>Regional specific approval</u>	
KCC marking for Korea	W28
<u>Tag name plate</u>	
Stainless steel TAG plate (1 x 24 x 80 mm), wire fixed. Font size depends on text length: 8 mm for 1 ... 10 characters, 4 mm for 11 ... 20 characters (specify in plain text).	Y17
<u>Accessories</u>	
Alignment rods-set for DN 100 ... 650 (4" ... 26") Ø = 25 mm, L = 500 mm, 3 pcs.	S10
Alignment rods-set for DN 700 ... 1900 (28" ... 76") Ø = 25 mm, L = 500 mm, 6 pcs.	S11
Alignment rods-set for DN 2000 ... 2400 (80" ... 96") Ø = 25 mm, L = 500 mm, 8 pcs.	S12
Spanner key for transducer mounting type SONO 3200 O-ring type	T11
Tool set with various mounting/spare parts for SONOKIT installation	T12

Operating instructions

Description	Article No.
SITRANS FUS060	
• English	A5E01204521
• German	A5E02123845
SITRANS FUS080	
• English	A5E03059912
• German	A5E31628428
SITRANS F US SONOKIT 1-path	
• English	A5E00814557
• German	A5E02610428

All literature is available to download for free, in a range of languages, at www.siemens.com/processinstrumentation/documentation



Please use online Product selector to get latest updates. Product selector link:

www.pia-portal.automation.siemens.com

Flowmeter SONOKIT (with FUS060 or FUS080)

Selection and Ordering data		Article No.	Ord. code	Selection and Ordering data		Article No.	Ord. code
SITRANS F US SONOKIT		7	ME 3 2 2 0 -	SITRANS F US SONOKIT		7	ME 3 2 2 0 -
2-path sensor				2-path sensor			
Click on the Article No. for the online configuration in the PIA Life Cycle Portal.							
Diameter	Qn setting [m³/h]			Transducer holder			
DN 200 (8")	380	2 F		Carbon steel, length = 160 mm, mounting plates in carbon steel	1		
DN 250 (10")	600	2 K		Stainless steel, length = 160 mm, mounting plates in stainless steel	2		
DN 300 (12")	850	2 P		Stainless steel, length = 230 mm, for concrete pipe (DN 600 ... DN 3000)	3		
DN 350 (14")	1000	2 T		Transducer type and approval			
DN 400 (16")	1300	3 B		IP67 (NEMA 4X/6) PA housing, PN 40, O-ring, 100 °C (212 °F), no approval	1		
DN 450 (18")	1700	3 F		IP68 SS housing, PN 40, O-ring, 180 °C (356 °F), EEx d, ATEX approval (only with standard FUS060)	2		
DN 500 (20")	2200	3 K		IP68 PA housing, Sylgard potting kit, PN 40, SS, O-ring, 100 °C (212 °F), no approval	3		
DN 550 (22")	2600	3 P		IP68 SS housing, Sylgard potting kit, PN 40, SS, O-ring, 200 °C (392 °F), no approval	4		
DN 600 (24")	3200	3 T		IP67 SS housing, PN 40, O-ring, 190 °C (374 °F), Ex i, ATEX approval (only with FUS060 Ex)	5		
DN 650 (26")	3600	4 B		Cable gland entires			
DN 700 (28")	4200	4 F		Cable glands M20 in transducers and in transmitter M25/20/16 x 1.5 (FUS080 only M20)	1		
DN 750 (30")	4800	4 K		Cable glands ½" NPT in transducers and in transmitter (only with FUS060)	2		
DN 800 (32")	5500	4 P		Transmitter version of SITRANS FUS060			
DN 900 (36")	7500	5 B		(only DN 200 ... 4000 (8" ... 160"))			
DN 1000 (40")	9000	5 K		IP65 (NEMA 4), 120/230 V AC			N
DN 1100 (44")	10 000	5 P		IP65 (NEMA 4), 24 V AC/DC			P
DN 1200 (48")	13 200	5 T		IP65 (NEMA 4), 24 V AC/DC Ex version			Q
Only for FUS060				Transmitter version of SITRANS FUS080			
DN 1300 (52")	14 000	6 A		(only DN 200 ... 1200 (8" ... 48"))			
DN 1400 (56")	16 800	6 C		PDM software tool and IrDA-adaptor, which are needed for settings update, to be ordered separately, see FUS080 accessories			
DN 1500 (60")	19 000	6 E		IP67/NEMA 4X/6 115 ... 230 V AC			U
DN 1600 (64")	22 800	6 G		IP67/NEMA 4X/6 3.6 V battery version, incl. dual battery pack			V
DN 1700 (68")	25 000	6 J		IP67/NEMA 4X/6 115 ... 230 V AC, incl. 3.6 V single battery backup			W
DN 1800 (72")	27 600	6 L		IP67/NEMA 4X/6 3.6 V battery version (no battery pack included) ⁴⁾			X
DN 1900 (76")	31 000	6 N		Transmitter output module			
DN 2000 (80")	36 000	6 Q		Transmitter SITRANS FUS080:			
DN 2100 (84")	37 000	6 S		Pulse and/or alarm output (standard for FUS080).			A
DN 2200 (88")	42 000	6 U		Transmitter SITRANS FUS060:			
DN 2300 (92")	45 000	6 W		HART, 1 pulse output, 1 relay			B
DN 2400 (96")	51 000	7 A		HART Ex version, 1 pulse output, 1 relay			C
DN 2500 (100")	53 000	7 C		PROFIBUS PA, 1 pulse/frequency			D
DN 2600 (104")	60 000	7 E					
DN 2700 (108")	62 000	7 G					
DN 2800 (112")	72 000	7 J					
DN 2900 (116")	71 000	7 L					
DN 3000 (120")	78 000	7 N					
Installation method¹⁾							
Empty pipe (incl. transducer holder and mounting plates). Alignment rods and tools must be ordered as accessories.		A					
Hot tap, mounting under pressure (mounting plates not incl.). Special mounting tools to be ordered separately.		B					

¹⁾ Mounting tools must be ordered separately as "-Z" options

Flow Measurement

SITRANS F US Inline

Flowmeter SONOKIT (with FUS060 or FUS080)

Selection and Ordering data	Article No.	Ord. code
SITRANS F US SONOKIT 2-path sensor	7ME3220-	
Transducer coaxial cables (with FUS080 only, 15 and 30 m, 70°C (158 °F) cable types)		
4 x 3 m, max. 70 °C (158 °F), the only option for Ex i		0
4 x 15 m, max. 70 °C (158 °F)		1
4 x 30 m, high temp. max. 200 °C (392 °F)		2
4 x 30 m, max. 70 °C (158 °F)		3
4 x 60 m, max. 70 °C (158 °F) (up to DN 3000)		4
4 x 90 m, max. 70 °C (158 °F) (up to DN 3000)		5
4 x 120 m, max. 70 °C (158 °F) (up to DN 3000)		6
4 x 3 m, high temp. max. 200 °C (392 °F), the only option for Ex i		7
4 x 15 m, high temp. max. 200 °C (392 °F)		8
Special version (add Order code):		
No transducer cable, cable length 4 x 3 m, the only option for Ex i		9 R 0 A
No transducer cable, cable length 4 x 15 m		9 R 0 B
No transducer cable, cable length 4 x 30 m		9 R 0 C
No transducer cable, cable length 4 x 60 m (up to DN 3000)		9 R 0 D
No transducer cable, cable length 4 x 90 m (up to DN 3000)		9 R 0 E
No transducer cable, cable length 4 x 120 m (up to DN 3000)		9 R 0 F

Selection and Ordering data	Order code
Additional information	
Please add „-Z“ to Article No. and specify Order code(s) and plain text.	
Material certificate	
EN 10204-3.1, transducer body material	F30
EN 10204-3.1, transducer holder material	F31
EN 10204-3.1, mounting plate material	F32
Tag name plate	
Stainless steel TAG plate (1 x 24 x 80 mm), wire fixed. Font size depends on text length: 8 mm for 1 ... 10 characters, 4 mm for 11 ... 20 characters (specify in plain text).	Y17
Regional specific approval	
KCC marking for Korea	W28
Accessories	
Alignment rods-set for DN 100 ... 750 (4" ... 30") Ø = 25 mm, L = 500 mm, 3 pcs.	S10
Alignment rods-set for DN 800 ... 2100 (32" ... 84") Ø = 25 mm, L = 500 mm, 6 pcs.	S11
Alignment rods-set for DN 2200 ... 3000 (88" ... 120") Ø = 25 mm, L = 500 mm, 8 or 10 pcs.	S12
Spanner key for transducer mounting type SONO 3200 O-ring type	T11
Tool set with various mounting/spare parts for SONOKIT installation	T12

Operating instructions

Description	Article No.
SITRANS FUS060	
• English	A5E01204521
• German	A5E02123845
SITRANS FUS080	
• English	A5E03059912
• German	A5E31628428
SITRANS F US SONOKIT 2-path	
• English	A5E02445496
• German	A5E02554972

All literature is available to download for free, in a range of languages, at www.siemens.com/processinstrumentation/documentation



Please use online Product selector to get latest updates. Product selector link:

www.pia-portal.automation.siemens.com





Flowmeter SONOKIT accessories and spare parts



Accessories

Potting kit for SONO 3200 terminal housing

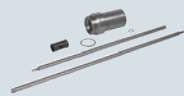
Description	Article No.	
Potting kit for terminal box of SONO 3200 transducers for IP68/NEMA 6P (not for Ex sensors)	FDK:085L2403	

Tools for SONO 3200 transducers and SONOKIT

Description	Article No.	
Extraction tool for replacement of SONO 3200 O-ring transducers under pressure and for hot-tapping (working conditions: typically water, max. 40 bar and max. 60 °C (max. 580 psi and max. 140 °F)) For transducer length:		
• Up to 160 mm (6.3")	FDK:085B5333	
• Up to 230 mm (9.1")	FDK:085B5335	
Angle measurement tool for SONOKIT	FDK:085B5330	
Hot-tap drilling tool for SONOKIT, the extraction tool is required, max. pressure 40 bar (580 psi)	FDK:085B5392	
Alignment tool for SONOKIT (typically for hot-tapping) For use on pipe sizes in the range DN 300 to DN 1200.	FDK:085B5393	

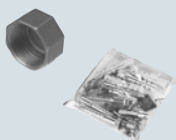
Description	Article No.	
Alignment rods-set for DN 100 ... 650 (4" ... 26"), Ø = 25 mm, L = 500 mm, 3 pcs.	A5E02609214	
Alignment rods-set for DN 700 ... 1900 (28" ... 76"), Ø = 25 mm, L = 500 mm, 6 pcs.	A5E02609215	
Alignment rods-set for DN 2000 ... 3000 (80" ... 120"), Ø = 25 mm, L = 500 mm, 10 pcs.	A5E02609216	
Spanner key for transducer mounting type SONO 3200 O-ring type	A5E02609218	
Tool set with various mounting/spare parts for SONOKIT installation	A5E02609219	

Flow Measurement

SITRANS F US Inline

Flowmeter SONOKIT (with FUS060 or FUS080)

Cable connection boxes

(For the connection of individual transducer cables with the FUS060 transducer cables)

Description	Article No.
Junction box for coaxial cable	
• IP65 metal box for 2 coaxial cables	FDK:085B1360
• IP65 metal box for 4 coaxial cables	FDK:085B1361
• IP65 EEx e plastic box for 2 coaxial cables, no ATEX approval	FDK:085B1362
• IP65 EEx e plastic box for 4 coaxial cables, no ATEX approval	FDK:085B1363



Spare parts

Transducer SONO 3200 spare parts, complete transducer with ½"-NPT cable glands

Transducer type	Material	Gasket	Pressure rating	Terminal housing	Approval	Temperature range [°C (°F)]	Length [mm (inch)]	Article No.
O-ring	316 SS	O-ring	PN 40	Plastic PA 6.6		-20 ... +100 (-4 ... +212)	160 (6.3)	A5E00839476
O-ring	316 SS	O-ring	PN 40	316 SS		-20 ... +200 ¹⁾ (-4 ... +392)	160 (6.3)	A5E00839435
O-ring	316 SS	O-ring	PN 40	Plastic PA 6.6		-20 ... +100 (-4 ... +212)	230 (9.41)	A5E00839477
O-ring	316 SS	O-ring	PN 40	316 SS		-20 ... +200 ¹⁾ (-4 ... +392)	230 (9.41)	A5E00839437



¹⁾ 316 SS housing for -20 ... +200 °C (-4 ... +392 °F) media temp. but cable glands only for -20 ... +100 °C (-4 ... +212 °F) ambient temp.

Transducer SONO 3200 spare parts, complete transducer with M20 cable glands

Transducer type	Material	Gasket	Pressure rating	Terminal housing	Approval	Temperature range [°C (°F)]	Length [mm (inch)]	Article No.
O-ring	316 SS	O-ring	PN 40	Plastic PA 6.6		-20 ... +100 (-4 ... +212)	160 (6.3)	FDK:085B5454
O-ring	316 SS	O-ring	PN 40	316 SS		-20 ... +200 ¹⁾ (-4 ... +392)	160 (6.3)	FDK:085B5455
O-ring	316 SS	O-ring	PN 40	Plastic PA 6.6		-20 ... +100 (-4 ... +212)	230 (9.41)	FDK:085B5458
O-ring	316 SS	O-ring	PN 40	316 SS	Ex d ²⁾	-20 ... +180 (-4 ... +356)	160 (6.3)	FDK:085B5452
O-ring	316 SS	O-ring	PN 40	316 SS	Ex i ³⁾	-10 ... +190 (14 ... 374)	160 (6.3)	A5E00836462
O-ring	316 SS	O-ring	PN 40	316 SS		-20 ... +200 ²⁾ (-4 ... +392)	230 (9.41)	FDK:085B5459



¹⁾ 316 SS housing for -20 ... +200 °C (-4 ... +392 °F) media temp. but cable glands only for -20 ... +100 °C (-4 ... +212 °F) ambient temp.

²⁾ ATEX (Ex) IIC 2G Ex d IIC T3-T6 Gb

³⁾ For systems with FUS060 ATEX IIC 2G Ex dem [ia/ib] T6/T4/T3

Transducer SONO 3200 spare parts, transducer terminal housing with M20 cable glands

Type	Article No.
Material: PA 6.6, Temperature range: -20 ... +100 °C (-4 ... +212 °F)	FDK:085B5501
Material: AISI 316, Temperature range: -20 ... +200 °C (-4 ... +392 °F)	FDK:085B5504
Material: AISI 316, Ex d ¹⁾ , Temperature range: -20 ... +180 °C (-4 ... +356 °F)	FDK:085B5505
Material: AISI 316, Ex i ²⁾ , Temperature range: -10 ... +190 °C (14 ... 374 °F)	A5E00835255



¹⁾ ATEX (Ex) IIC 2G Ex d IIC T3-T6 Gb

²⁾ For systems with FUS060 ATEX IIC 2G Ex dem [ia/ib] T6/T4/T3

Flowmeter SONOKIT (with FUS060 or FUS080)

Transducer SONO 3200 spare parts, transducer terminal housing with ½"-NPT cable glands

Type	Article No.	
Material: PA 6.6, Temperature range: -20 ... +100 °C (-4 ... +212 °F)	A5E00839460	
Material: AISI 316, Temperature range: -20 ... +200 °C (-4 ... +392 °F)	A5E00839427	

Transducer SONO 3200 spare parts transducer body with insert as well as insert only

Temperature range [°C (°F)]	Gasket	Length [mm (inch)]	Article No.	
-20 ... +200 (-4 ... +392)	O-ring (FFKM O-ring material) ¹⁾	160 (6.3)	FDK:085B1406	
-20 ... +200 (-4 ... +392)	O-ring (FKM 602 O-ring material) ²⁾	160 (6.3)	FDK:085B5510	
-20 ... +200 (-4 ... +392)	O-ring	230 (9.41)	FDK:085B5511	

¹⁾ Chemical resistant O-ring material. Body specially for Ex-approved transducers.

²⁾ Body specially for standard transducers.

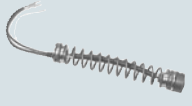
Temperature range [°C (°F)]	Length [mm (inch)]	Article No.	
-20 ... +200 (-4 ... +392)	160 (6.3)	FDK:085B1419	
-20 ... +200 (-4 ... +392)	230 (9.41)	FDK:085B1420	

Transducer SONO 3200 gasket

Type	Pressure rating	Material	Temperature range [°C (°F)]	Article No.	
Gasket O-ring (3 pcs. for O-ring transducers)	PN 40	FKM	-20 ... +200 (-4 ... +392)	FDK:085B1089	

Cables for SONOKIT SONO 3200 transducers with FUS060

Description	Length [m (ft)]	Article No.	
Coaxial cable for FUS060, (75 Ω, max. 70 °C (158 °F), black PVC) (2 pcs.)	3 (9.84)	A5E00875101	
	15 (49.21)	A5E00861432	
	30 (98.43)	A5E01278662	
	60 (196.85)	A5E01278682	
	90 (295.28)	A5E01278687	
	120 (393.70)	A5E01278698	
High temp. coaxial cable for FUS060; with 0.3 m brown PTFE high temp. transducer part, max. 200 °C (392 °F) and black PVC transmitter part with SMB plug, max. 70 °C (158 °F); (impedance 75 Ω) (2 pcs.)	3 (9.84)	A5E00875105	
	15 (49.21)	A5E00861435	
	30 (98.43)	A5E01196952	

Cables for SONOKIT SONO 3200 transducers with FUS080

Description	Length [m (ft)]	Article No.	
Coaxial cable for FUS080, (75 Ω, max. 70 °C (158 °F), black PVC) (2 pcs.)	15 (49.21)	A5E02478541	
	30 (98.43)	A5E02478751	

Flow Measurement

SITRANS F US Inline

Flowmeter SONOKIT (with FUS060 or FUS080)

Transducer holder for SONOKIT SONO 3200 transducers

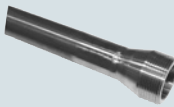
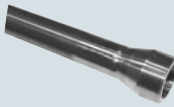
Description	Article No.	
1-path (each incl. 1 pc.)		
• 160 mm (6.3") stainless steel 45°, DN 100 ... DN 150 (4" ... 6")	FDK:085L1103	
• 160 mm (6.3") carbon steel 45°, DN 100 ... DN 150 (4" ... 6")	FDK:085L1102	
• 230 mm (9.1") for concrete pipe 60°, DN 600 ... DN 2400 (24" ... 96")	FDK:085L1107	
• 160 mm (6.3") stainless steel 60°, DN 200 ... DN 2400 (8" ... 96")	FDK:085L1105	
• 160 mm (6.3") carbon steel 60°, DN 200 ... DN 2400 (8" ... 96")	FDK:085L1104	
2-path (each incl. 1 pc.)		
• 230 mm (9.1") for concrete pipe 60°, DN 600 ... DN 3000 (24" ... 120")	FDK:085L1111	
• 160 mm (6.3") stainless steel 60°, DN 200 ... DN 3000 (8" ... 120")	FDK:085L1109	
• 160 mm (6.3") carbon steel 60°, DN 200 ... DN 3000 (8" ... 120")	FDK:085L1108	

The other transducer holder parts are either completely in stainless steel for the concrete and stainless steel pipes (AISI 316L/1.4404 or similar). For carbon pipes the part welded onto the pipe is in carbon steel (St.37 or similar). Thread part is stainless steel (AISI 316L/1.4404 or similar).

Mounting plate for SONOKIT SONO 3200 transducers

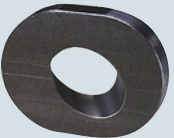
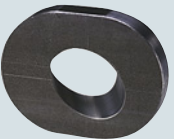
Description	Article No.	
1-path (each incl. 1 pc.)		
• Stainless steel plate, 45°, DN 100 ... DN 150 (4" ... 6")	FDK:085L1113	
• Carbon steel plate, 45°, DN 100 ... DN 150 (4" ... 6")	FDK:085L1112	
• Stainless steel plate, 60°, DN 200 ... DN 2400 (8" ... 96")	FDK:085L1115	
• Carbon steel plate, 60°, DN 200 ... DN 2400 (8" ... 96")	FDK:085L1114	
2-path (each incl. 1 pc.)		
• Stainless steel plate, 60°, DN 200 ... DN 3000 (8" ... 120")	FDK:085L1119	
• Carbon steel plate, 60°, DN 200 ... DN 3000 (8" ... 120")	FDK:085L1118	

The mounting plates are either in stainless steel (AISI 316L/1.4404 or similar) or carbon steel (St.37 or similar).

SONO 3200 cable glands

Type/ description	Tempera- ture range [°C (°F)]	Appr	Article No.	
black PA plastic, cable Ø 5 ... 13 mm (1 pc.)	-20 ... 100 (-4 ... +212)		A5E02246304	
½" NPT gray PA plastic, cable Ø 5 ... 9 mm (1 pc.)	-20 ... 100 (-4 ... +212)		A5E02246309	
½" NPT chrome-plated brass, cable Ø 5 ... 9 mm (1 pc.)	-40 ... 100 (-40 ... +212)		A5E02246258	
M20 stainless steel, cable Ø 4 ... 6 mm (1 pc.)	-25 ... 200 (-13 ... +392)	Ex i	A5E02246194	
M20 stainless steel, cable Ø 5 ... 8 mm (1 pc.)	-60 ... 180 (-76 ... +356)	Ex d	A5E02246311	

Schematics

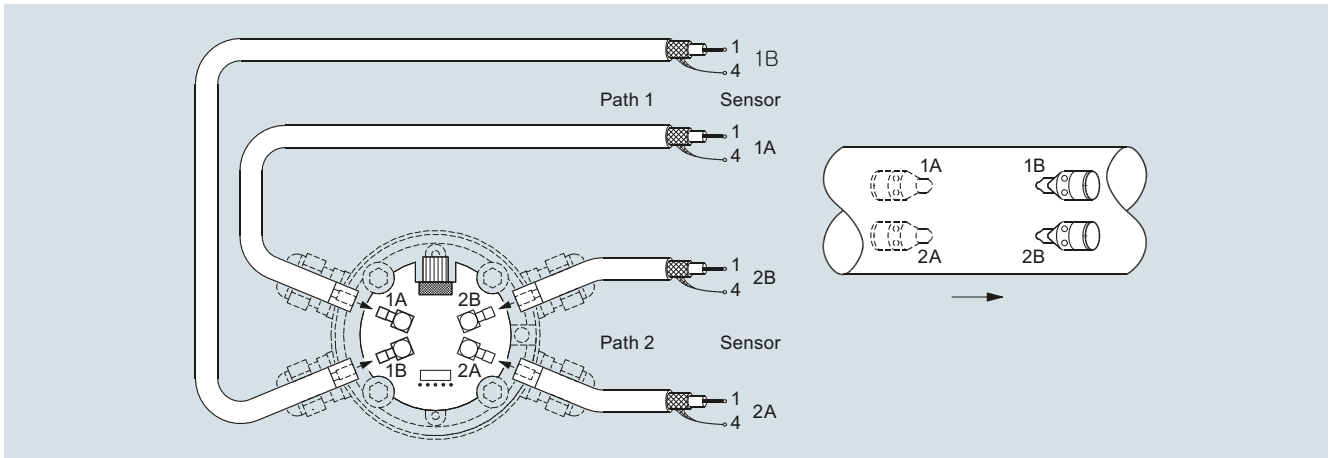

Electrical connection of SITRANS FUS060 and SONOKIT 2-path. Max. 30 m transducer cable length for sizes \geq DN 3000.

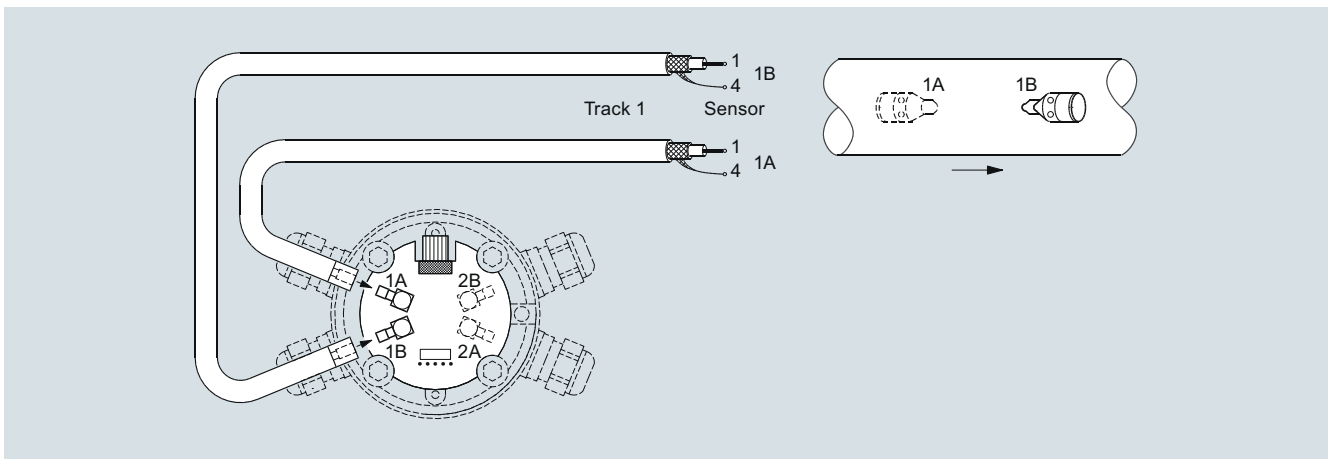

Electrical connection of SITRANS FUS060 and SONOKIT 1-path

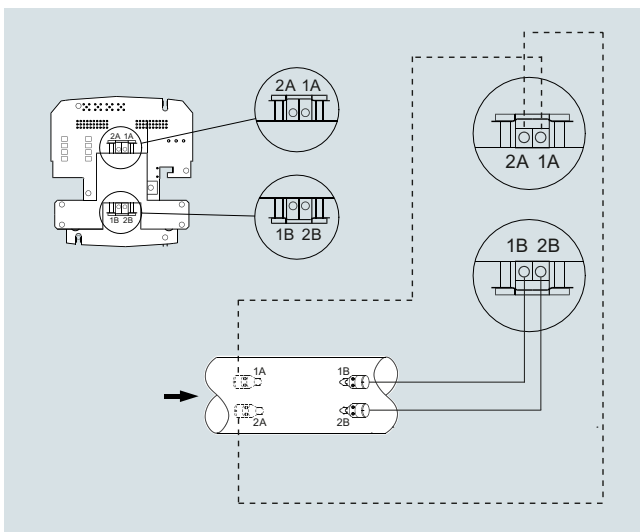

Electrical connection of SITRANS FUS080 and SONOKIT 2-path

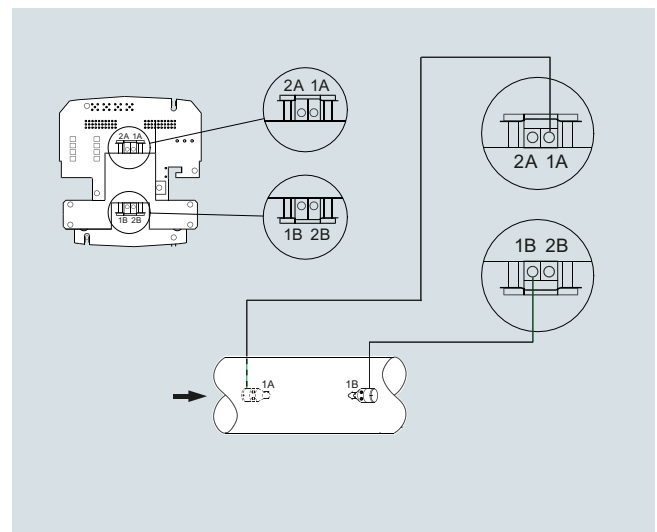

Electrical connection of SITRANS FUS080 and SONOKIT 1-path

Flow Measurement

SITRANS F US Inline

Flowmeter SITRANS FUS380 standard

Overview



The 2-path flowmeter SITRANS FUS380 comes as battery or mains-powered and is designed to measure water flow in district heating plants local networks, boiler stations, substations, chiller plants (including glycol mixes), and other general water applications.

The type-approved flowmeter version is named SITRANS FUE380 - see page 3/294.

Technically, the meter types SITRANS FUS380 and SITRANS FUE380 are completely identical, only difference is the calibration limit and the type approval for custody transfer.

Benefits

- Battery-powered up to 6 years
- 115/230 V mains-powered with back-up battery option in case of mains power failure
- Fast measuring frequency 15 Hz/0.5 Hz (230 V AC/Battery)
- Easy one-button straight forward display
- 2-path measuring principle for optimum accuracy
- Compact or remote mounting
- Measures on most district water qualities and water conductivities
- No pressure drop
- Long-term stability
- 2 galvanically isolated digital outputs for easy connection to a calculator (potential-free)
- Analog output 4 to 20 mA
- Bidirectional measurement, with 2 totalizers and outputs
- Dynamic range Q_i (min) : Q_s (max) up to 1:400

Application

The main application for SITRANS FUS380 is measurement of water flow or water flow in energy meter systems in district heating networks or chilled water (including glycol mixes).

Design

The 2-path design of SITRANS FUS380 ensures maximum accuracy under short inlet conditions. The flowmeter consists of a flow sensor pipe, 4 transducers/transducer cables and a transmitter SITRANS FUS080.

The unit is available in a compact or a remote version. Both versions are pre-mounted with short coax-cables. Remote transmitter up to a distance of 30 m by one Sensor link cable (SSL).

Compact mounting is only possible up to 120 °C (248 °F). The sensor must be isolated to protect transmitter from heat. The transmitter is available in an IP67/NEMA 4X/6 enclosure.

Integration

The flowmeter digital output is often used as input for an energy meter or as input for digital systems for remote reading.

SITRANS FUS380 has two digital output functions that can be individually selected.

Pulse output rate is defined when ordering. To get optimal benefit the pulse value must be selected as low as possible.

If the flowmeter forms part of an energy meter system for custody transfer, no further approvals are needed, except possible local approvals on the flowmeter.

Function

Together with the SIMATIC PDM tool the FUS380 offers the possibility of testing and verifying the flowmeter on site and creating a printed "Qualification Certificate" with specific data that defines the quality status of the measurement.

The Qualification Certificate shows information about the actual status of the flowmeter:

- General settings, flowmeter and battery information, totalizer values, and pulse output settings
- Detailed information about the transmitter and the sensor functionality, and a main parameter list for evaluating the functionality of the flowmeter

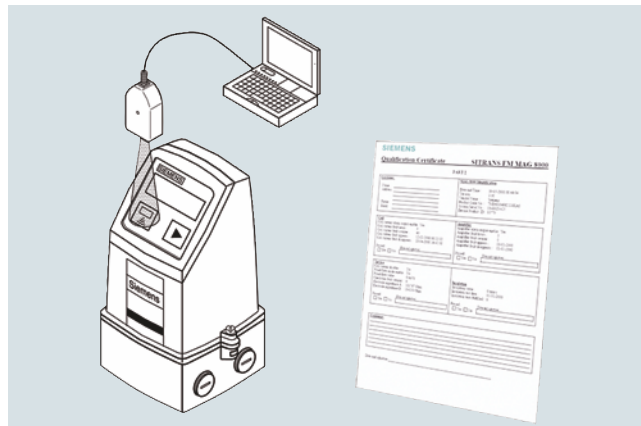

Configuration SITRANS FUS380

Selection guide SITRANS FUS380, standard version

DN	Q _s (m ³ /h)	Q _{max} (m ³ /h) (105 % of Q _s)	Q _p (m ³ /h)	Q _i (m ³ /h) (1:100 of Q _p)	Cut-off (m ³ /h)	Cut-off (% of Q _{max})	Typical pulse value ¹⁾ (l/pulse)
50	15	15.75	15	0.15	0.075	0.48	1
50	45	47.25	15	0.15	0.075	0.16	1
50	45	47.25	30	0.3	0.150	0.32	1
65	25	26.25	25	0.25	0.125	0.48	1
65	72	75.6	25	0.25	0.125	0.17	1
65	72	75.6	50	0.5	0.250	0.33	1
80	40	42	40	0.4	0.200	0.48	2.5
80	120	126	40	0.4	0.200	0.16	2.5
80	120	126	80	0.8	0.400	0.32	2.5
100	60	63	60	0.6	0.300	0.48	2.5
100	180	189	60	0.6	0.300	0.16	2.5
100	240	252	120	1.2	0.600	0.24	2.5
125	10	10.5	100	1	0.500	4.76	2.5
125	280	294	100	1	0.500	0.17	2.5
125	400	420	200	2	1.000	0.24	2.5
150	150	157.5	150	1.5	0.750	0.48	10
150	420	441	150	1.5	0.750	0.17	10
150	560	588	300	3	1.500	0.26	10
200	250	262.5	250	2.5	1.250	0.48	10
200	700	735	250	2.5	1.250	0.17	10
200	900	945	500	5	2.500	0.26	10
250	400	420	400	4	2.000	0.48	10
250	1 120	1 176	400	4	2.000	0.17	10
250	1 400	1 470	800	8	4.000	0.27	10
300	560	588	560	5.6	2.800	0.48	50
300	1 560	1 638	560	5.6	2.800	0.17	50
300	2 100	2 205	1 120	11.2	5.600	0.25	50
350	750	787.5	750	7.5	3.750	0.48	50
350	2 100	2 205	750	7.5	3.750	0.17	50
350	2 800	2 940	1 500	15	7.500	0.26	50
400	950	9 97.5	950	9.5	4.750	0.48	50
400	2 660	2 793	950	9.5	4.750	0.17	50
400	3 600	3 780	1 900	19	9.500	0.25	50
500	1 475	1 548.75	1 475	14.75	7.375	0.48	100
500	4 130	4 336.5	1 475	14.75	7.375	0.17	100
500	5 500	5 775	2 950	29.5	14.750	0.26	100
600	2 150	2 257.5	2 150	21.5	10.750	0.48	100
600	6 020	6 321	2 150	21.5	10.750	0.17	100
600	8 000	8 400	4 300	43	21.500	0.26	100
700	2 900	3 045	2 900	29	14.500	0.48	100
700	8 120	8 526	2 900	29	14.500	0.17	100
700	10 800	11 340	5 800	58	29.000	0.26	100
800	3 800	3 990	3 800	38	19.000	0.48	100
800	10 640	11 172	3 800	38	19.000	0.17	100
800	14 200	14 910	7 600	76	38.000	0.25	100
900	5 000	5 250	3 800	38	19.000	0.36	100
900	14 000	14 700	5 000	50	25.000	0.17	100
900	20 000	21 000	5 000	50	25.000	0.12	100
1 000	6 000	6 300	3 800	38	19.000	0.30	100
1 000	16 800	17 640	6 000	60	30.000	0.17	100
1 000	24 000	25 200	12 000	120	60.000	0.24	100
1 200	9 000	9 450	3 800	38	19.000	0.20	100
1 200	25 200	26 460	9 000	90	45.000	0.17	100
1 200	36 000	37 800	18 000	180	90.000	0.24	100

The values Q_i, Q_p and Q_s are shown on the system label of the FUS380. Q_i (Q_{min}) means the minimal and Q_p (Q_{nom}) the nominal flow rate. Q_s is the highest operatable flow rate. The maximum flow rate (Q_{max}) is 105 % of Q_s. The low flow cut-off is 50 % of Q_i.

In order to obtain best pulse output resolution in the range Q_{min} to Q_s of approx. 100 Hz at Q_s, two or three flow values for every dimension can be selected at ordering. Therefore the ordering data table also shows Q_p (Q_n). This flow rate is between Q_i (Q_{min}) and Q_s and indicates the normal or typical flow.

To get optimal benefit of the pulses the pulse value and pulse length shall be selected as low as possible. The following calculation formula can be used for determining the shortest pulse value at a pulse length of 5 ms: L/pulse > Q_s (m³/h) /360.

For example Q_s = 300 m³/h; L/pulse > 300/360; L/pulse > 0.83; therefore the pulse value must be 1 l/pulse

¹⁾ Typical pulse values for SITRANS FUS380 with pulse length 5 ms. Other values are possible - please see the selections at the 7ME340 Order codes.

Flow Measurement

SITRANS F US Inline

Flowmeter SITRANS FUS380 standard

Technical specifications

Sensor design	2-path sensor with flanges and inline transducers wet-calibrated from factory
Nominal size (DN 50 ... DN 80 in bronze)	DN 50, 65, 80, 100, 125, 150, 200, 250, 300, 350, 400, 500, 600, 700, 800, 900, 1000, 1200
Pressure rate	PN 16, PN 25, PN 40 EN 1092-1 flanges: • type 01 (B): DN 100 to DN 125 • type 11 (B): DN 150 to DN 1200 • type 11 (B) 'design': DN 50 to DN 80
Pipe material	• DN 100 ... DN 1200: Carbon Steel EN 1.0345/P235 GH, painted in light-gray. • DN 50 ... 80: Die-cast bronze G-CuSn10/W2.1050.01 (EN 1982)
Transducer design	• DN 100 ... DN 1200: Inline version and welded onto the pipe • DN 50 ... DN 80: Screwed into the pipe
Transducer material	Stainless steel (AISI 316/1.4404)/brass (CuZn ₃₆ Pb ₂ As)

Sensor operating conditions

Ambient temperature	
• Operation	-10 ... +60 °C (14 ... 140 °F) (MID version: -10 ... +55 °C (14 ... 131 °F))
• Storage	-40 ... +85 °C (-40 ... +185 °F)
Measured media	Heating water, according to VDI-2035 (pH 8.2 - 10.5), industrial VdTUV information sheet 1466 and AGFW information sheet FW 510.
Media/surface temperature	
• DN 100 ... DN 1200	Remote: 2 ... 200 °C (35.6 ... 392 °F)
• DN 50 ... DN 80	Remote: 2 ... 150 °C (35.6 ... 302 °F)
• DN 50 ... DN 1200	Compact: 2 ... 120 °C (35.6 ... 248 °F)
Degree of protection	Sensor connection IP67/NEMA 4X/6
Max. flow velocity	DN 50 ... DN 1200: 9 m/s (29.5 ft/s)
Electromagnetic compatibility	
• Emitted interference	To EN 55011/CSPRI-11
• Noise immunity	To EN/IEC 61236-1 (Industry)

Transmitter

The transmitter related to this system is the SITRANS FUS080. Technical specifications to the FUS080 see page 3/253 ff.

Sensor cable

Transducer cable length	Pre-mounted with short coax-cables
Sensor link cable length (SSL)	5, 10, 20, 30 m (16.4, 32.8, 65.6, 98.4 ft)

Certificates and approvals

Conformity certificate (CE)	The devices are supplied as standard with a Siemens Certificate of Conformity on DVD
Material certificate	Material certificate according EN 3.1 is optionally available
Calibration report	A standard calibration report is shipped with every flowmeter. Extended accredited ISO/IEC 17025 calibration certificates optionally available
Approvals	No custody transfer approvals

The sensors are approved according to EU directive 2014/68/EU dated 27 June 2014 regarding fluid group 1, classified in category III. Design according to EN 13480 (PED Directive).

SITRANS FUS380 uncertainty

	FUS380
Flow value setting	Predefined settings according to dimension
Approval	No approval
Flow rate v_f	0.02 ... 9 m/s (0.065 ... 29.5 ft/s)
Output A	Pulse: forward, reverse, forward net, reverse net (Preset: forward)
Output B	Pulse (forward, reverse, forward net, reverse net, alarm, call-up (Preset: alarm))
Pulse value A & B (depending on DN value)	0.1 l/p, 0.25 l/p, 0.5 l/p, 1 l/p, 2.5 l/p, 10 l/p, 25 l/p, 50 l/p, 100 l/p, 250 l/p, 500 l/p, 1 m ³ /p, 2.5 m ³ /p, 5 m ³ /p, 10 m ³ /p, 25 m ³ /p, 50 m ³ /p, 100 m ³ /p, 250 m ³ /p, 500 m ³ /p, 1000 m ³ /p
Pulse width	5/10/20/50/100/200/500 ms
Flow unit setup	Preset: m ³ /h
Volume unit setup	Preset: m ³

Flowmeter Calibration and traceability

To ensure continuous accurate measurement, flowmeters must be calibrated. The calibration is conducted at Siemens flow facilities with traceable instruments referring directly to the physical unit of measurement according to the International System of Units (SI).

Therefore, the calibration certificate ensures recognition of the test results worldwide, including the US (NIST traceability). Siemens offers accredited calibrations assured to ISO 17025 in the flow range from 0.0001 m³/h to 10 000 m³/h. Siemens Flow Instruments accredited laboratories are recognized by ILAC MRA (International Laboratory Accreditation Corporation - Mutual Recognition Arrangement) ensuring international traceability and recognition of the test results worldwide.

A standard calibration certificate with Q_n as selected flow is shipped with each SITRANS FUS380. This production calibration protocol consists of 2 x 3 points at Q_i , 10 % Q_p and Q_p (max. 4 200 m³/h).

Accuracy SITRANS FUS380:

± 0.5 % for 0.5 m/s < v < 10 m/s and ± 0.25/V_{act} [%] below 0.5 m/s

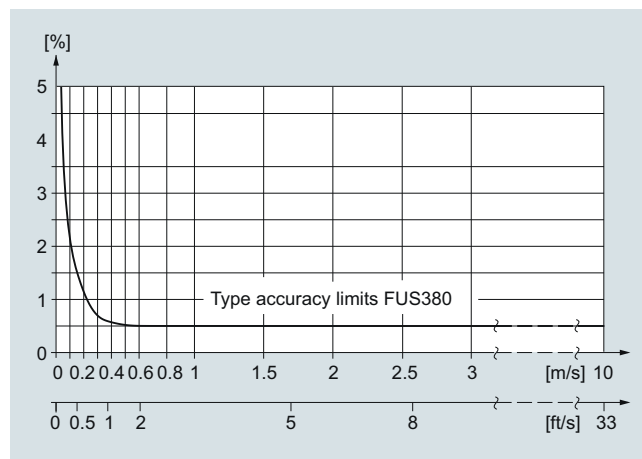

Selection and Ordering data				Article-No.	Order code
Flowmeter SITRANS FUS380 (standard)				7ME3400 -	0 - A
↗ Click on the Article No. for the online configuration in the PIA Life Cycle Portal.					
Diameter	Approval	Pressure rating	Flow setting [m ³ /h]		
			Q _p (Q _n) is the normal flow according to the approval requirements. Q _p and Q _s is shown on the system label. Qp (Qn) Qs		
Pipe material: Die-cast bronze					
DN 50 (2")	EN 1434	PN 40	15	15	1 A
DN 50 (2")	EN 1434	PN 40	15	45	1 C
DN 50 (2")	OIML R75	PN 40	30	45	1 D
DN 65 (2½")	EN 1434	PN 40	25	25	1 E
DN 65 (2½")	EN 1434	PN 40	25	72	1 G
DN 65 (2½")	OIML R75	PN 40	50	72	1 H
DN 80 (3")	EN 1434	PN 40	40	40	1 J
DN 80 (3")	EN 1434	PN 40	40	120	1 L
DN 80 (3")	OIML R75	PN 40	80	120	1 M
Pipe material: Carbon steel					
DN 100 (4")	EN 1434	PN16, PN 40	60	60	1 N
DN 100 (4")	EN 1434	PN16, PN 40	60	180	1 Q
DN 100 (4")	OIML R75	PN16, PN 40	120	240	1 R
DN 125 (5")	EN 1434	PN16, PN 40	100	100	1 S
DN 125 (5")	EN 1434	PN16, PN 40	100	280	1 U
DN 125 (5")	OIML R75	PN16, PN 40	200	400	1 V
DN 150 (6")	EN 1434	PN16, PN 40	150	150	2 A
DN 150 (6")	EN 1434	PN16, PN 40	150	420	2 C
DN 150 (6")	OIML R75	PN16, PN 40	300	560	2 D
DN 200 (8")	EN 1434	PN16, PN 25, PN 40	250	250	2 E
DN 200 (8")	EN 1434	PN16, PN 25, PN 40	250	700	2 G
DN 200 (8")	OIML R75	PN16, PN 25, PN 40	500	900	2 H
DN 250 (10")	EN 1434	PN16, PN 25, PN 40	400	400	2 J
DN 250 (10")	EN 1434	PN16, PN 25, PN 40	400	1 120	2 L
DN 250 (10")	OIML R75	PN16, PN 25, PN 40	800	1 400	2 M
DN 300 (12")	EN 1434	PN16, PN 25	560	560	2 N
DN 300 (12")	EN 1434	PN16, PN 25	560	1 560	2 Q
DN 300 (12")	OIML R75	PN16, PN 25	1 120	2 100	2 R
DN 350 (14")	EN 1434	PN16, PN 25	750	750	2 S
DN 350 (14")	EN 1434	PN16, PN 25	750	2 100	2 U
DN 350 (14")	OIML R75	PN16, PN 25	1 500	2 800	2 V
DN 400 (16")	EN 1434	PN16, PN 25	950	950	3 A
DN 400 (16")	EN 1434	PN16, PN 25	950	2 660	3 C
DN 400 (16")	OIML R75	PN16, PN 25	1 900	3 600	3 D
DN 500 (20")	EN 1434	PN16, PN 25	1 475	1 475	3 J
DN 500 (20")	EN 1434	PN16, PN 25	1 475	4 130	3 L
DN 500 (20")	OIML R75	PN16, PN 25	2 950	5 500	3 M
DN 600 (24")	EN 1434	PN16, PN 25	2 150	2 150	3 S
DN 600 (24")	EN 1434	PN16, PN 25	2 150	6 020	3 U
DN 600 (24")	OIML R75	PN16, PN 25	4 300	8 000	3 V
DN 700 (28")	EN 1434	PN16, PN 25	2 900	2 900	4 E
DN 700 (28")	EN 1434	PN16, PN 25	2 900	8 120	4 G
DN 700 (28")	OIML R75	PN16, PN 25	5 800	10 800	4 H
DN 800 (32")	EN 1434	PN16, PN 25	3 800	3 800	4 N
DN 800 (32")	EN 1434	PN16, PN 25	3 800	10 640	4 Q
DN 800 (32")	OIML R75	PN16, PN 25	7 600	14 200	4 R

Flow Measurement

SITRANS F US Inline

Flowmeter SITRANS FUS380 standard

Selection and Ordering data					Article-No.	Order code
Flowmeter SITRANS FUS380 (standard)					7ME3400 -	0 - A
Diameter	Approval	Pressure rating	Flow setting [m ³ /h] Qp (Qn)	Qs		
<u>Remote only</u>						
DN 900 (36")	EN 1434	PN16, PN 25	5 000	5 000	5 A	
DN 900 (36")	EN 1434	PN16, PN 25	5 000	14 000	5 C	
DN 900 (36")	OIML R75	PN16, PN 25	10 000	20 000	5 D	
DN 1 000 (40")	EN 1434	PN16, PN 25	6 000	6 000	5 J	
DN 1 000 (40")	EN 1434	PN16, PN 25	6 000	16 800	5 L	
DN 1 000 (40")	OIML R75	PN16, PN 25	12 000	24 000	5 M	
DN 1 200 (48")	EN 1434	PN16	9 000	9 000	5 S	
DN 1 200 (48")	EN 1434	PN16	9 000	25 200	5 U	
DN 1 200 (48")	OIML R75	PN16	18 000	36 000	5 V	
Flange norm and pressure rating						
System without sensor - only a transmitter FUS080 as spare part - settings as defined with this Article No.						A
<u>EN 1092-1 Flanges</u>						
PN 16 (DN 100 ... DN 1 200)						C
PN 25 (DN 200 ... DN 1 000)						D
PN 40 (DN 50 ... DN 250)						E
Compact/remote connection						
Note: Sensor cable always firmly connected to connection box.						
Compact version, Liquid max. 120 °C (248 °F)						0
<u>Remote version, Liquid max. 150/200 °C (302/392 °F)</u>						
<u>Sensor link cable (SSL)</u>						
• 5 m (16.4 ft)						2
• 10 m (32.8 ft)						3
• 20 m (65.6 ft)						4
• 30 m (98.4 ft)						5
Pulse output value setup						
To get optimal benefit of the pulses the pulse value and pulse length shall be selected as low as possible. The following calculation formula can be used for determining the shortest pulse value at a pulse length of 5 ms: $L/pulse > Q_s (m^3/h) / 360$. For example $Q_s = 300 m^3/h$; $L/pulse > 300/360$; $L/pulse > 0.83$; therefore the pulse value must be 1 l/pulse						
<u>Pulse value</u>						
• 0.1 l/pulse						1
• 1 l/pulse						2
• 2.5 l/pulse						3
• 10 l/pulse						4
• 50 l/pulse						5
• 100 l/pulse						6
• 250 l/pulse						7
• 1 m ³ /pulse						8
• 0.25 l/pulse						9
• 0.5 l/pulse						9
• 5 l/pulse						9
• 25 l/pulse						9
• 500 l/pulse						9
• 2.5 m ³ /pulse						9
• 5 m ³ /pulse						9
• 10 m ³ /pulse						9
• 25 m ³ /pulse						9
• 50 m ³ /pulse						9
• 100 m ³ /pulse						9
• 250 m ³ /pulse						9
• 500 m ³ /pulse						9
• 1000 m ³ /pulse						9
						N 0 A
						N 0 B
						N 0 C
						N 0 D
						N 0 E
						N 0 F
						N 0 G
						N 0 H
						N 0 J
						N 0 K
						N 0 L
						N 0 M
						N 0 N
						N 0 P

Flow Measurement

SITRANS F US Inline

Flowmeter SITRANS FUE380 with CT approval

Overview



The 2-path flowmeter SITRANS FUE380 comes as battery or mains-powered and is designed to measure water flow in district heating plants, local networks, boiler stations, substations, chiller plants (including glycol mixes without type approval) and other general water applications.

The flowmeter FUE380 is approved according to energy meter standards EN 1434 class 2, OIML R 75 class 2 and MID class 2. Metrological parameters are protected against manipulation. The type-approved flowmeter version is named SITRANS FUE380. For a standard flowmeter type FUS380 without a type approval, see separate FUS380 chapter.

Technically, the meter types SITRANS FUS380 and SITRANS FUE380 are completely identical, only difference is the calibration limit and the type approval for custody transfer.

Benefits

- Battery-powered up to 6 years
- 115/230 V mains-powered with back-up battery option in case of mains power failure
- Fast measuring frequency 15 Hz/0.5 Hz (230 V AC/Battery)
- Easy one-button straight forward display
- 2-path measuring principle for optimum accuracy
- Compact or remote mounting
- Measures on most district water qualities and water conductivities
- No pressure drop
- Long-term stability
- 2 galvanically isolated digital outputs for easy connection to a calculator (potential-free)
- Analog output 4 to 20 mA
- Bidirectional measurement, with 2 totalizers and outputs
- Dynamic range $Q_i:Q_p$ up to 1:50/100 or max. range $Q_i:Q_s$ up to 1:400

Application

The main application for SITRANS FUE380 is measurement of water flow or water flow in energy meter systems for custody transfer in district heating networks or chilled water (including glycol mixes without type approval).

Combined with an energy calculator and a pair of temperature sensors, SITRANS FUE380 can be used as part of an energy meter system. For this purpose Siemens offers energy calculator SITRANS FUE950.

Design

The 2-path design of SITRANS FUE380 ensures maximum accuracy under short inlet conditions. The approved flowmeter consists of a flow sensor pipe, 4 transducers/transducer cables and a transmitter SITRANS FUE080.

The unit is available in a compact or a remote version. Both versions are pre-mounted with short coax-cables. Remote transmitter up to a distance of 30 m by one Sensor link cable (SSL).

Compact mounting is only possible up to 120 °C (248 °F). The sensor must be isolated to protect transmitter from heat. The transmitter is available in an IP67/NEMA 4X/6 enclosure.

FUE380 MI-004 approval

The SITRANS FUE380 program is type-approved according to international energy meter standard EN 1434. On 1 November 2006 the MI-004 energy meter directive became effective providing that all energy meters with a MI-004 verification label can be sold across the EU borders.

The FUE380 are MI-004 verified and labeled products according to Directive 2014/32/EU of the European Parliament and Council of 26 February, 2014 on measuring instruments, Annex VI Thermal Energy Meters (MI-004), in sizes from DN 50 to DN 1200.

The MID certification is obtained as module B + module D approvals according to the above-mentioned directive.

Module B: MI-004 Type MID approval according to EN 1434: 2007 (approved for media water)

Module D: Quality insurance MID approval of production

The MID system label with the approval information is placed on the side of the transmitter and on the sensor. An example of the product label is shown below:

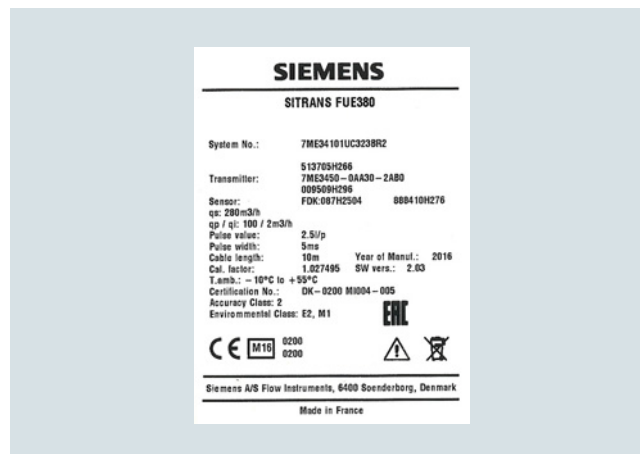

FUE380 transmitter label (with MID first verification)

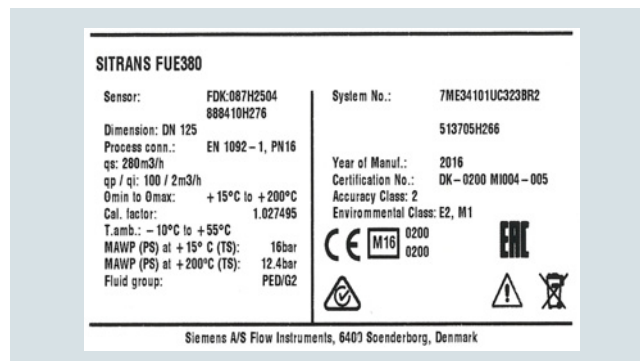

FUE380 sensor label (with MID first verification)

Flow Measurement

SITRANS F US Inline

Flowmeter SITRANS FUE380 with CT approval

Configuration SITRANS FUE380 type-approved

Selection guide SITRANS FUE380, type-approved flowmeter

DN	Q _s (m ³ /h)	Q _{max} (m ³ /h) (105 % of Q _s)	Q _p (m ³ /h)	Q _i (m ³ /h)	Q _i (m ³ /h)	Cut-off (m ³ /h)	Cut-off (% of Q _{max})	Typical pulse value (l/pulse)
				(1:50 of Q _p) EN 1434/MID	(1:100 of Q _p) OIML R 75/MID			
50	30	31.5	15	0.3	-	0.075	0.24	1
50	45	47.25	15	0.3	-	0.075	0.16	1
50	45	47.25	30	-	0.30	0.150	0.32	1
65	50	52.5	25	0.5	-	0.125	0.24	1
65	72	75.6	25	0.5	-	0.125	0.17	1
65	72	75.6	50	-	0.50	0.250	0.33	1
80	80	84	40	0.8	-	0.200	0.24	2.5
80	120	126	40	0.8	-	0.200	0.16	2.5
80	120	126	80	-	0.80	0.400	0.32	2.5
100	120	126	60	1.2	-	0.300	0.24	2.5
100	180	189	60	1.2	-	0.300	0.16	2.5
100	180	189	120	-	1.20	0.600	0.32	2.5
125	200	210	100	2.0	-	0.500	0.24	2.5
125	280	294	100	2.0	-	0.500	0.17	2.5
125	280	294	200	-	2.00	1.000	0.34	2.5
150	300	315	150	3.0	-	0.750	0.24	10
150	420	441	150	3.0	-	0.750	0.17	10
150	420	441	300	-	3.00	1.500	0.34	10
200	500	525	250	5.0	-	1.250	0.24	10
200	700	735	250	5.0	-	1.250	0.17	10
200	700	735	500	-	5.00	2.500	0.34	10
250	800	840	400	8.0	-	2.000	0.24	10
250	1 120	1 176	400	8.0	-	2.000	0.17	10
250	1 120	1 176	800	-	8.00	4.000	0.34	10
300	1 120	1 176	560	11.2	-	2.800	0.24	50
300	1 560	1 638	560	11.2	-	2.800	0.17	50
300	1 560	1 638	1120	-	11.20	5.600	0.34	50
350	1 500	1 575	750	15.0	-	3.750	0.24	50
350	2 100	2 205	750	15.0	-	3.750	0.17	50
350	2 100	2 205	1 500	-	15.00	7.500	0.34	50
400	1 900	1 995	950	19.0	-	4.750	0.24	50
400	2 660	2 793	950	19.0	-	4.750	0.17	50
400	2 660	2 793	1 900	-	19.00	9.500	0.34	50
500	2 950	3 097.5	1 475	29.5	-	7.375	0.24	100
500	4 130	4 336.5	1 475	29.5	-	7.375	0.17	100
500	4 130	4 336.5	2 950	-	29.50	14.75	0.34	100
600	4 300	4 515	2 150	43.0	-	10.75	0.24	100
600	6 020	6 321	2 150	43.0	-	10.75	0.17	100
600	6 020	6 321	4 300	-	43.00	21.50	0.34	100
700	5 800	6 090	2 900	58.0	-	14.50	0.24	100
700	8 120	8 526	2 900	58.0	-	14.50	0.17	100
700	8 120	8 526	5 800	-	58.00	29.00	0.34	100
800	7 600	7 980	3 800	76.0	-	19.00	0.24	100
800	10 640	11 172	3 800	76.0	-	19.00	0.17	100
800	10 640	11 172	7 600	-	76.00	38.00	0.34	100
900	10 000	10 500	5 000	100.0	-	25.00	0.24	100
900	14 000	14 700	5 000	100.0	-	25.00	0.17	100
900	14 000	14 700	10 000	-	100.00	50.00	0.34	100

Flowmeter SITRANS FUE380 with CT approval

DN	Q_s (m ³ /h)	Q_{max} (m ³ /h) (105 % of Q_s)	Q_p (m ³ /h)	Q_i (m ³ /h)	Q_i (m ³ /h)	Cut-off (m ³ /h)	Cut-off (% of Q_{max})	Typical pulse value (l/pulse)
				(1:50 of Q_p) EN 1434/MID	(1:100 of Q_p) OIML R 75/MID			
1 000	12 000	12 600	6 000	120.0	-	30.00	0.24	100
1 000	16 800	17 640	6 000	120.0	-	30.00	0.17	100
1 000	16 800	17 640	12 000	-	120.00	60.00	0.34	100
1 200	18 000	18 900	9 000	180.0	-	45.00	0.24	100
1 200	25 200	26 460	9 000	180.0	-	45.00	0.17	100
1 200	25 200	26 460	18 000	-	180.00	90.00	0.34	100

Dynamic range $Q_i:Q_p$: better than 1:100 or 1:50 according to OIML R 75 class 2 and MID EN 1434 class 2.

Q_i (Q_{min}) means the minimal and Q_p (Q_{nom}) the nominal flow rate according to the approval requirements.

Q_s is the highest operatable flow rate. The maximum flow rate (Q_{max}) is 105 % of Q_s . The low flow cut-off is 50 % of Q_i .

Q_i , Q_p and Q_s are shown on the system nameplate of the FUE380.

In order to obtain best pulse output resolution in the range Q_{min} to Q_s of approx. 100 Hz at Q_s , two or three flow values for every dimension can be selected at ordering. Therefore the ordering data table also shows Q_p (Q_n). This flow rate is between Q_i (Q_{min}) and

Note:

The minimum flow (Q_i) should be checked in the PIA-portal or product master data base (PMD)

To get optimal benefit of the pulses the pulse value and pulse length shall be selected as low as possible. The following calculation formula can be used for determining the shortest pulse value at a pulse length of 5 ms: $L/pulse > Q_s$ (m³/h) /360.

For example $Q_s = 300$ m³/h; $L/pulse > 300/360$; $L/pulse > 0.83$; therefore the pulse value must be 1 l/pulse

Flow Measurement

SITRANS F US Inline

Flowmeter SITRANS FUE380 with CT approval

Technical specifications

Pipe design	2-path sensor with flanges and inline transducers wet-calibrated from factory
Nominal size welded version (DN 50 ... DN 80 in bronze)	DN 50, 65, 80, 100, 125, 150, 200, 250, 300, 350, 400, 500, 600, 700, 800, 900, 1000, 1200
Pressure rate	PN 16, PN 25, PN 40 EN 1092-1 flanges: • type 01 (B): DN 100 to DN 125 • type 11 (B): DN 150 to DN 1200 • type 11 (B) 'design': DN 50 to DN 80
Pipe material	• DN 100 ... DN 1200: Carbon Steel EN 1.0345/P235 GH, painted in light-gray. • DN 50 ... DN 80: Die-cast bronze G-CuSn10/W2.1050.01 (EN 1982)
Transducer design	• DN 100 ... DN 1200: Inline version and welded onto the pipe • DN 50 ... DN 80: Screwed into the pipe
Transducer material	Stainless steel (AISI 316/1.4404)/brass (CuZn ₃₆ Pb ₂ As)

Sensor operating conditions

Ambient temperature	
• Operation	-10 ... +60 °C (14 ... 140 °F) (MID version: -10 ... +55 °C (14 ... 131 °F))
• Storage	-40 ... +85 °C (-40 ... +185 °F)
Measured media	Heating water, according to VDI-2035 (pH 8.2 - 10.5), industrial VdTÜV information sheet 1466 and AGFW information sheet FW 510.
Media/surface temperature	
• DN 100 ... DN 1200	Remote: 2 ... 200 °C (35.6 ... 392 °F) MID: min. +15 °C/+59 °F
• DN 50 ... DN 80	Remote: 2 ... 150 °C (35.6 ... 302 °F) MID: min. +15 °C/+59 °F
• DN 50 ... DN 1200	Compact: 2 ... 120 °C (35.6 ... 248 °F) MID: min. +15 °C/+59 °F
Degree of protection	Sensor connection IP67/NEMA 4X/6
Electromagnetic compatibility	
• Emitted interference	To EN 55011/CISPR-11
• Noise immunity	To EN/IEC 61326-1 (Industry)
• MID	Environment class E2 and M1
Max. flow velocity at Q _s	DN 50 ... DN 1200: 9 m/s (29.5 ft/s)

Transmitter

The transmitter related to this system is the SITRANS FUE080.
Technical specifications to the FUE080 see page 3/253 ff.

Sensor cable

Transducer cable length	Pre-mounted with short coax-cables
Sensor link cable length (SSL)	5, 10, 20, 30 m (16.4, 32.8, 65.6, 98.4 ft)

Certificates and approvals

Conformity certificate (CE)	The devices are supplied as standard with a Siemens Certificate of Conformity on DVD
Material certificate	Material certificate according EN 10204-3.1 is optionally available
Calibration report	A standard calibration report is shipped with every flowmeter. Extended accredited ISO/IEC 17025 calibration certificates optionally available
Approvals	<ul style="list-style-type: none"> Approval standards: EN 1434 and OIML R 75 Class 2 Type approval: MID, MI-004, class 2 approval and certification (according to EN 1434) CPA/CMC (China)

The sensors are approved according to EU directive 2014/68/EU dated 27 June 2014 regarding fluid group 1, classified in category III. Design according to EN 13480 (PED Directive).

Type-dependent settings

Flow value	Predefined according to EN 1434/OIML R 75/MID
Approval	Country specific
Flow rate v _f	0.02 ... 9 m/s (0.065 ... 29.5 ft/s)
Output A	Preset: Forward pulses
Output B	Preset: Alarm
Pulse value A & B (depending on DN value)	Preset: See scheme - previous page Preset for SITRANS FUE950 or free selectable depending on flow rate (Q _s)
Pulse width	Preset: 5 ms
Flow unit setup	Preset: m ³ /h
Volume unit setup	Preset: m ³

Flowmeter Calibration and traceability

To ensure continuous accurate measurement, flowmeters must be calibrated. The calibration is conducted at Siemens flow facilities with traceable instruments referring directly to the physical unit of measurement according to the International System of Units (SI).

Therefore, the calibration certificate ensures recognition of the test results worldwide, including the US (NIST traceability). Siemens offers accredited calibrations assured to ISO 17025 in the flow range from 0.0001 m³/h to 10 000 m³/h. Siemens Flow Instruments accredited laboratories are recognized by ILAC MRA (International Laboratory Accreditation Corporation - Mutual Recognition Arrangement) ensuring international traceability and recognition of the test results worldwide.

A standard calibration certificate with Q_n as selected flow is shipped with each SITRANS FUE380. This production calibration protocol consists of 2 x 3 points at Q_i, 10 % Q_p and Q_p (max. 4 200 m³/h).

Typical accuracy SITRANS FUE380:

$$\pm(0.5 + 0.02 Q_p/Q) [\%]$$

Q_p according to EN 1434/OIML requirements.

Example: DN 100, $Q_p = 60 \text{ m}^3/\text{h}$ at $Q = 1.2 \text{ m}^3/\text{h}$:

Accuracy at $1.2 \text{ m}^3/\text{h} = \text{typical } 1.5 \%$

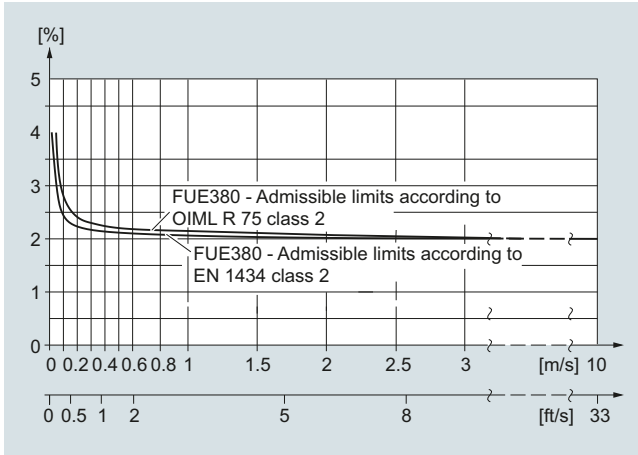

SITRANS FUE380 fulfils the requirements

$E_f = \pm(2 + 0.02 Q_p/Q_i) \text{ max. } \pm 5 \%$, according to EN 1434 and OIML R 75, class 2 or MID class 2 requirements.

Flow Measurement

SITRANS F US Inline

Flowmeter SITRANS FUE380 with CT approval

Selection and Ordering data

Article No. Order code

Flowmeter SITRANS FUE380 (type-approved)



7ME3410 - - - - -

Click on the Article No. for the online configuration in the PIA Life Cycle Portal.

Diameter	Approval	Pressure rating	Flow setting [m ³ /h]		
			Q _p [m ³ /h]	Q _s [m ³ /h]	
Pipe material: Die-cast bronze					
DN 50 (2")	EN 1434	PN 40	15	30	1 B
DN 50 (2")	EN 1434	PN 40	15	45	1 C
DN 50 (2")	OIML R75	PN 40	30	45	1 D
DN 65 (2½")	EN 1434	PN 40	25	50	1 F
DN 65 (2½")	EN 1434	PN 40	25	72	1 G
DN 65 (2½")	OIML R75	PN 40	50	72	1 H
DN 80 (3")	EN 1434	PN 40	40	80	1 K
DN 80 (3")	EN 1434	PN 40	40	120	1 L
DN 80 (3")	OIML R75	PN 40	80	120	1 M
Pipe material: Carbon steel					
DN 100 (4")	EN 1434	PN16, PN 40	60	120	1 P
DN 100 (4")	EN 1434	PN16, PN 40	60	180	1 Q
DN 100 (4")	OIML R75	PN16, PN 40	120	180	1 R
DN 125 (5")	EN 1434	PN16, PN 40	100	200	1 T
DN 125 (5")	EN 1434	PN16, PN 40	100	280	1 U
DN 125 (5")	OIML R75	PN16, PN 40	200	280	1 V
DN 150 (6")	EN 1434	PN16, PN 40	150	300	2 B
DN 150 (6")	EN 1434	PN16, PN 40	150	420	2 C
DN 150 (6")	OIML R75	PN16, PN 40	300	420	2 D
DN 200 (8")	EN 1434	PN16, PN 25, PN 40	250	500	2 F
DN 200 (8")	EN 1434	PN16, PN 25, PN 40	250	700	2 G
DN 200 (8")	OIML R75	PN16, PN 25, PN 40	500	700	2 H
DN 250 (10")	EN 1434	PN16, PN 25, PN 40	400	800	2 K
DN 250 (10")	EN 1434	PN16, PN 25, PN 40	400	1 120	2 L
DN 250 (10")	OIML R75	PN16, PN 25, PN 40	800	1 120	2 M
DN 300 (12")	EN 1434	PN16, PN 25	560	1 120	2 P
DN 300 (12")	EN 1434	PN16, PN 25	560	1 560	2 Q
DN 300 (12")	OIML R75	PN16, PN 25	1 120	1 560	2 R
DN 350 (14")	EN 1434	PN16, PN 25	750	1 500	2 T
DN 350 (14")	EN 1434	PN16, PN 25	750	2 100	2 U
DN 350 (14")	OIML R75	PN16, PN 25	1 500	2 100	2 V
DN 400 (16")	EN 1434	PN16, PN 25	950	1 900	3 B
DN 400 (16")	EN 1434	PN16, PN 25	950	2 660	3 C
DN 400 (16")	OIML R75	PN16, PN 25	1 900	2 660	3 D
DN 500 (20")	EN 1434	PN16, PN 25	1 475	2 950	3 K
DN 500 (20")	EN 1434	PN16, PN 25	1 475	4 130	3 L
DN 500 (20")	OIML R75	PN16, PN 25	2 950	41 30	3 M
DN 600 (24")	EN 1434	PN16, PN 25	2 150	4 300	3 T
DN 600 (24")	EN 1434	PN16, PN 25	2 150	6 020	3 U
DN 600 (24")	OIML R75	PN16, PN 25	4 300	6 020	3 V
DN 700 (28")	EN 1434	PN16, PN 25	2 900	5 800	4 F
DN 700 (28")	EN 1434	PN16, PN 25	2 900	8 120	4 G
DN 700 (28")	OIML R75	PN16, PN 25	5 800	8120	4 H
DN 800 (32")	EN 1434	PN16, PN 25	3 800	7 600	4 P
DN 800 (32")	EN 1434	PN16, PN 25	3 800	10 640	4 Q
DN 800 (32")	OIML R75	PN16, PN 25	7 600	10 640	4 R

Flow Measurement

SITRANS F US Inline

Flowmeter SITRANS FUE380 with CT approval

Selection and Ordering data	Article No.	Order code
Flowmeter SITRANS FUE380 (type-approved)	7ME3410 -	
Transmitter variant FUE080 power/analog output		
115 ... 230 V AC 3.6 V Lithium battery, dual pack is included 115 ... 230 V AC, backup 3.6 V DC Lithium battery, single pack is included 3.6 V battery version (no battery pack included) Option with 4 ... 20 mA analog output module • 115 ... 230 V AC • 115 ... 230 V AC, backup 3.6 V DC, Lithium battery, single pack is included Note: Lithium batteries are subject to special transportation regulations according to United Nations "Regulation of Dangerous Goods, UN 3090 and UN 3091". Special transport documentation is required to observe these regulations. This may influence both transport time and costs.		B D E G R U
Country specific design		A C M R S T U
Neutral, no approval mark China, PA 2008-T222 Russia, EN 1434/OIML R75 MID-Approval (MI004), Language on name plate English MID-Approval (MI004), Language on name plate German MID-Approval (MI004), Language on name plate Polish MID-Approval (MI004), Language on name plate French		
Pulse width setup		
Pulse width • 5 ms (standard) • 10 ms • 20 ms • 50 ms • 100 ms • 200 ms • 500 ms		2 2 3 4 5 6 7 8

Selection and Ordering data	Order code
Additional information Please add „-Z“ to Article No. and following add-on code(s) with plain text.	
Calibration/certificate FUE380	
Approval, verification and approval sealing as defined with the article number. See Order code.	
Production calibration for DN 50 ... DN 1200 with Q_n as selected in diameter Incl. Calibration protocol: 2 x 3 points, Q_i , 10 % Q_p and Q_p (max. 8000 m ³ /h).	Included
3.1 Inspection certificate (EN 10204-3.1) - pipe material	C12
Accredited Siemens ISO/IEC 17025 calibration for DN 50 ... DN 200 with Q_n as selected in diameter. Certificate: 2 x 5 points, Q_i , 5 %, 10 %, 50 % and 100 % of Q_p (max. 630 m ³ /h).	D20
Accredited Siemens ISO/IEC 17025 calibration for DN 250 ... DN 600 with Q_n as selected in diameter. Certificate: 2 x 5 points, Q_i , 5 %, 10 %, 50 % and 100 % of Q_p (max. 2800 m ³ /h).	D21
Accredited Siemens ISO/IEC 17025 calibration, DN 500 ... DN 1200 with Q_n as selected in diameter. Certificate: 2 x 5 points, Q_i , 5 %, 10 %, 50 % and 100 % of Q_p (max. 8000 m ³ /h).	D22
Output B as reverse flow pulses. No calibration/verification of this function.	E21
Tag name plate	
Stainless steel TAG plate (1 x 24 x 80 mm), wire fixed. Font size depends on text length: 8 mm for 1 ... 10 characters, 4 mm for 11 ... 20 characters (specify in plain text).	Y17

Flowmeter SITRANS FUE380 operating instructions, accessories and spare parts

Operating instructions

Description	Article No.
• English	A5E00730100
• German	A5E00740611

All literature is available to download for free, in a range of languages, at www.siemens.com/processinstrumentation/documentation

For accessories and spare parts on page 3/257 see chapter of transmitter FUS080/FUE080.

Dimensional drawings

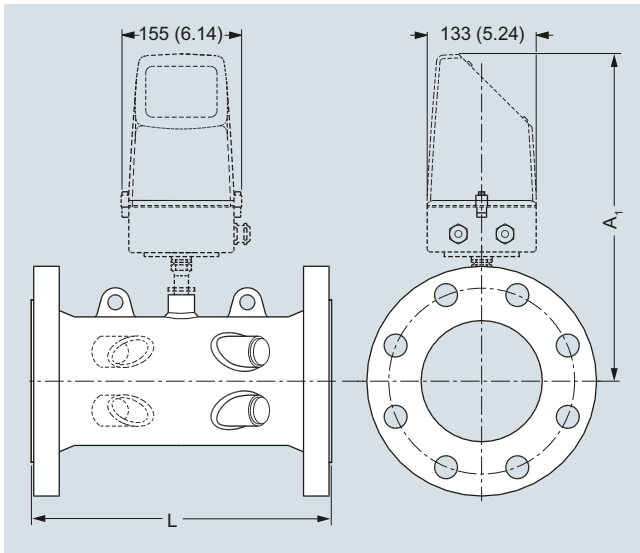

Transmitter IP67/NEMA 4X/6, wall mounting

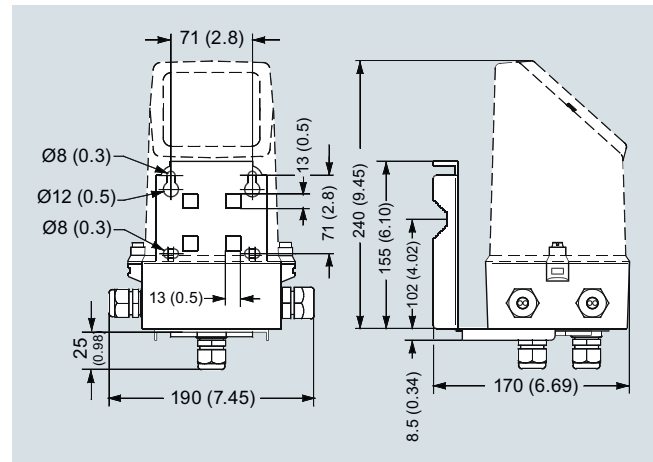

Dimensions in mm (inch)

Sensor dimensions for FUS380 and FUE380

Size DN	PN 16		PN 25		PN 40		A ₁ mm	Lift hug
	L mm	Weight kg	L mm	Weight kg	L mm	Weight kg		
50	-	-	-	-	300 +0/-2	10	350	No
65	-	-	-	-	300 +0/-2	15	363	No
80	-	-	-	-	350 +0/-2	18	370	No
100	350 +0/-2	15	-	-	350 +0/-2	18	372	No
125	350 +0/-2	18	-	-	350 +0/-2	24	385	No
150	500 +0/-3	28	-	-	500 +0/-3	34	399	No
200	500 +0/-3	38	500 +0/-3	47	500 +0/-3	55	425	Yes
250	600 +0/-3	60	600 +0/-3	76	600 +0/-3	91	452	Yes
300	500 +0/-3	66	500 +0/-3	81	-	-	478	Yes
350	550 +0/-3	94	550 +0/-3	121	-	-	495	Yes
400	600 +0/-3	124	600 +0/-3	153	-	-	520	Yes
500	625 +0/-3	194	625 +0/-3	231	-	-	570	Yes
600	750 +0/-3	303	750 +0/-3	365	-	-	622	Yes
700	875 +0/-3	361	875 +0/-3	553	-	-	673	Yes
800	1000 +0/-3	494	1000 +0/-3	770	-	-	724	Yes
900	1230 +0/-6	535	1300 +0/-6	835	-	-	775	Yes
1000	1300 +0/-6	594	1370 +0/-6	1000	-	-	826	Yes
1200	1360 +0/-6	732	-	-	-	-	928	Yes

Notes:

- Weight for transmitter/electronics 1.5 kg (compact version) or approximately 3 kg (remote version including 10 m cable set)
- - Means not available
- All weights are **approximate**
- For flange values - see norm EN 1092-1

Flow Measurement

SITRANS F US Inline

Flowmeter SITRANS FUS380 and FUE380

Size inch	PN 16		PN 25		PN 40		A ₁ inch	Lift hug
	L inch	Weight lb	L inch	Weight lb	L inch	Weight lb		
2	-	-	-	-	11.81 +0/-0.08	22	13.78	No
2½	-	-	-	-	11.81 +0/-0.08	33	14.30	No
3	-	-	-	-	13.78 +0/-0.08	40	14.57	No
4	13.78 +0/-0.08	33	-	-	13.78 +0/-0.08	40	14.65	No
5	13.78 +0/-0.08	40	-	-	13.78 +0/-0.08	53	15.16	No
6	19.68 +0/-0.12	62	-	-	19.68 +0/-0.12	75	15.71	No
8	19.68 +0/-0.12	84	19.68 +0/-0.12	104	19.68 +0/-0.12	121	16.74	Yes
10	23.62 +0/-0.12	132	23.62 +0/-0.12	168	23.62 +0/-0.12	201	17.80	Yes
12	19.68 +0/-0.12	146	19.68 +0/-0.12	179	-	-	18.82	Yes
14	21.65 +0/-0.12	207	21.65 +0/-0.12	267	-	-	19.49	Yes
16	23.62 +0/-0.12	273	23.62 +0/-0.12	337	-	-	20.48	Yes
20	24.61 +0/-0.12	428	24.61 +0/-0.12	509	-	-	22.45	Yes
24	29.53 +0/-0.12	668	29.53 +0/-0.12	805	-	-	24.49	Yes
28	34.45 +0/-0.12	796	34.45 +0/-0.12	1246	-	-	26.50	Yes
32	39.37 +0/-0.12	1089	39.37 +0/-0.12	1698	-	-	28.51	Yes
36	48.43 +0/-0.24	1179	51.18 +0/-0.24	1841	-	-	30.52	Yes
40	51.18 +0/-0.24	1310	53.94 +0/-0.24	2205	-	-	32.52	Yes
48	53.54 +0/-0.24	1614	-	-	-	-	36.54	Yes

Notes:

- Weight for transmitter/electronics 3.3 lb (compact version) or approximately 6.6 lb (remote version including 32.8 ft cable set)
- - Means not available
- All weights are **approximate**
- For flange values - see norm EN 1092-1

Schematics

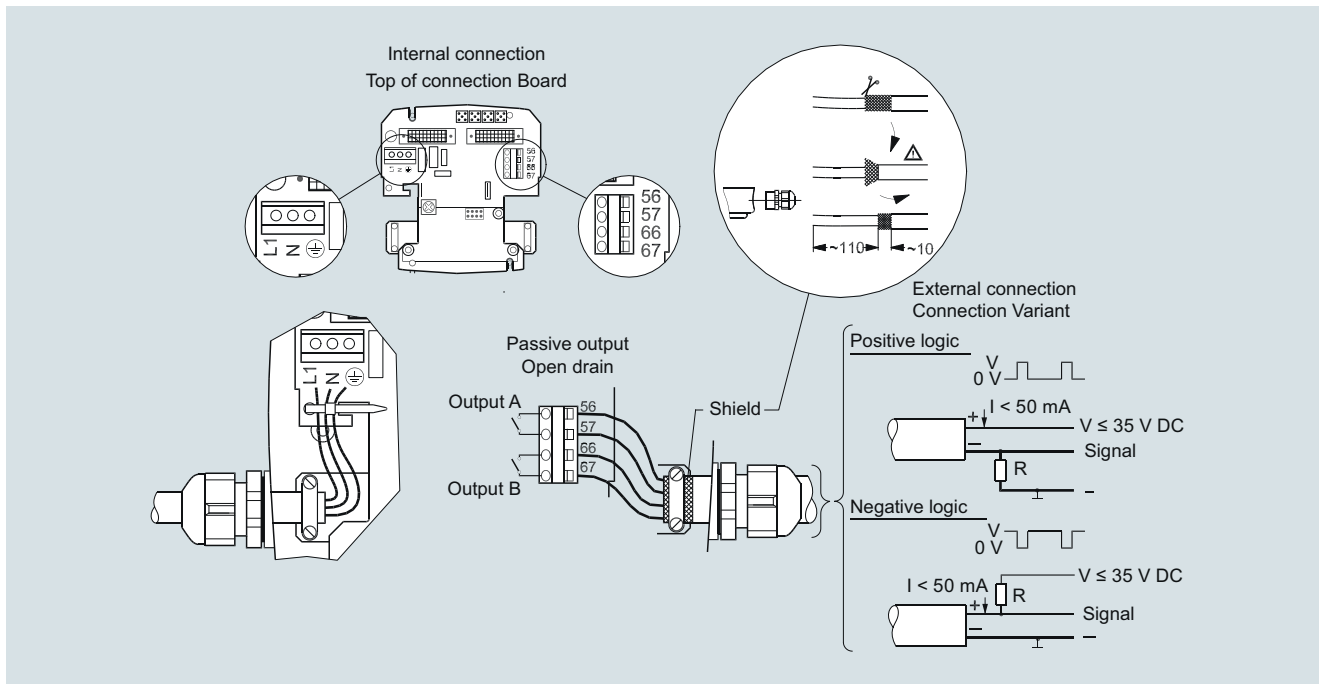

Electrical connection of transmitter SITRANS FUS/FUE380

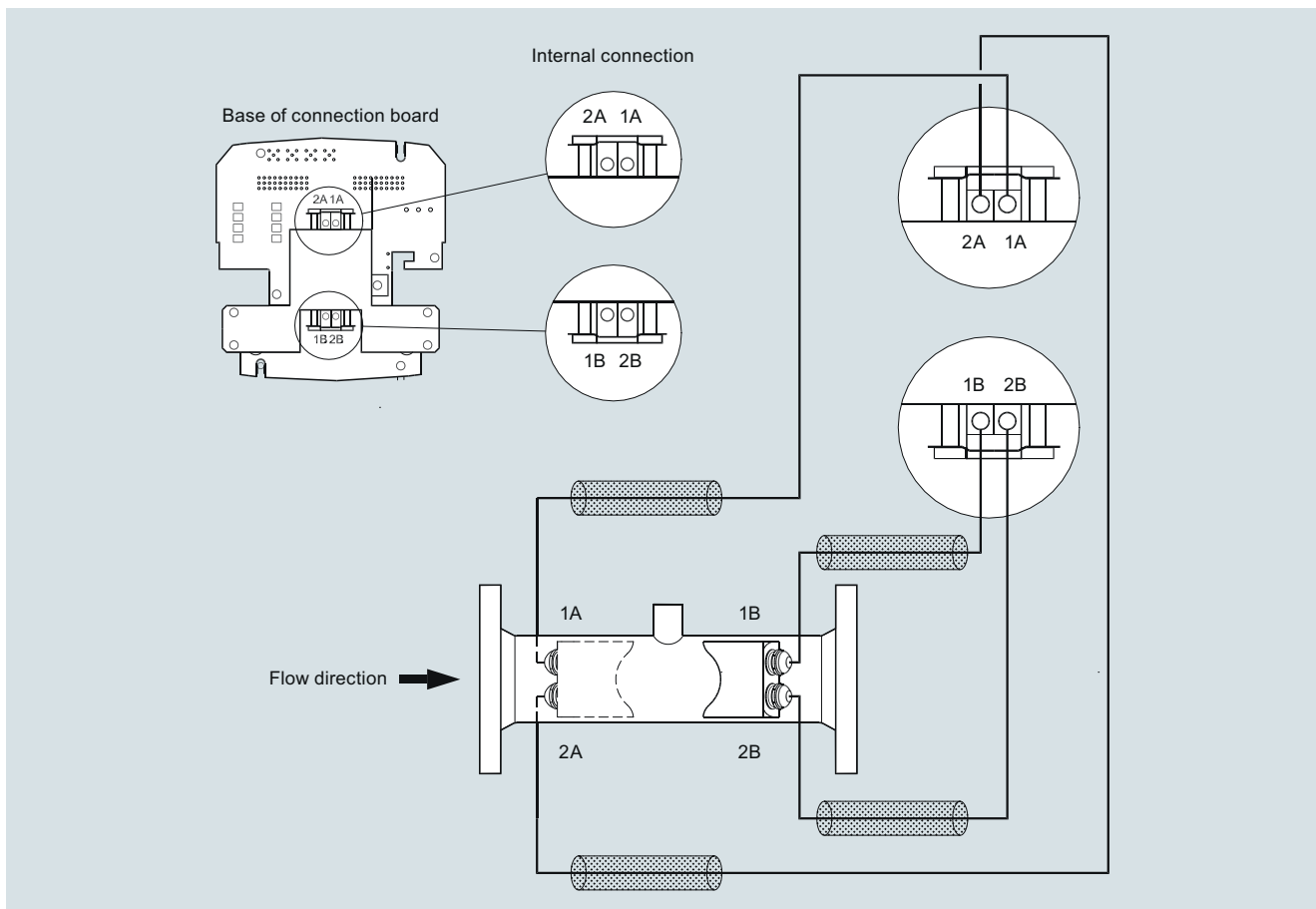

Electrical connection of sensor SITRANS FUS/FUE380

Flow Measurement

SITRANS F US Inline

SITRANS FUE950 energy calculator

Overview



SITRANS FUE950 is a universal thermal energy calculator, which meets the requirements EN 1434 and has the MID and PTB K7.2 approval for energy metering with the media water.

SITRANS FUE950 has been developed for the SITRANS FUS380/ FUE380 and alternatively MAG 5000/6000 or FST020. SITRANS FUE950 is modular in construction and can by order be fitted with optional modules depending on the application. The FUE950 supports none of the SITRANS FX, FC products and only some of the FUS clamp-on products.

Benefits

Basic functions

- Prepared for heating, cooling measurement
- Approval for MID for heat metering and PTB K7.2 for cooling
- High-accuracy thermal energy metering, meets EN1434 requirements
- Measured temperature range $-20 \dots +190 \text{ }^{\circ}\text{C}$ ($-4 \dots +374 \text{ }^{\circ}\text{F}$)
- Instantaneous values for energy/volume flow
- Battery or mains powered
- Battery version with battery lifetime of typically up to 10 years
- Optical data interface
- Real date and time
- Auto-detection of 2-wire or 4-wire temperature sensors

Additional functions

- Individual tariff functions
- Advanced functions for cooling/heating applications or the combination
- Memory for 24 periods (months, weeks, days)
- Data logger function
- Expandable functionality with 2 optional plug and play add-on modules
- Communication over M-Bus, RS 485 or RS 232

Add-on modules

- Plug-in module with 2 extra pulse inputs
- Plug-in module with 2 pulse outputs
- Plug-in module with combination of input and output pulses
- Plug-in module for M-Bus communication
- Plug-in module for RS 232 or RS 485 communication
- Plug-in module with 2 passive current outputs ($4 \dots 20 \text{ mA}$)

Application

The SITRANS FUE950 is able to handle 3 kinds of applications, means energy calculation in:

- District heating applications
- Chilled water applications
- Combined cooling/heating applications

Energy metering in heating, hot water applications (code "A" and "B")

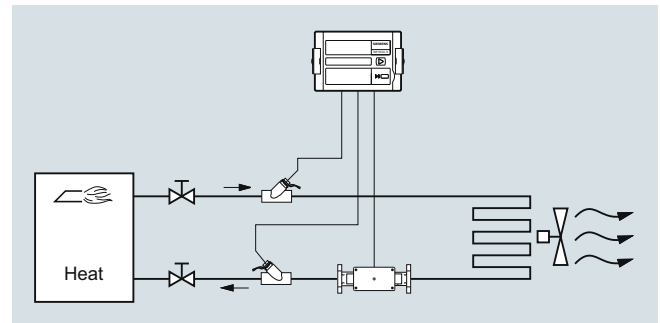

Energy metering in cooling, chilled water applications (code "C" and "D")

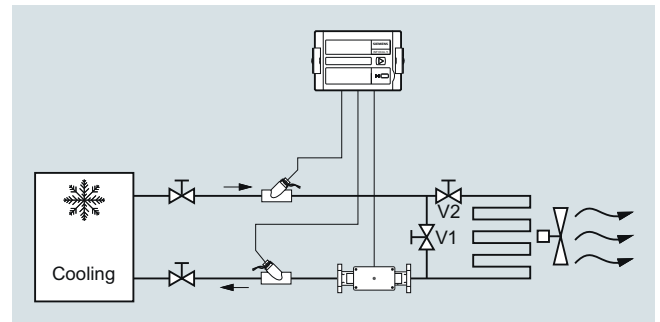

Energy metering in combined cooling/heating applications (code "E" and "F")

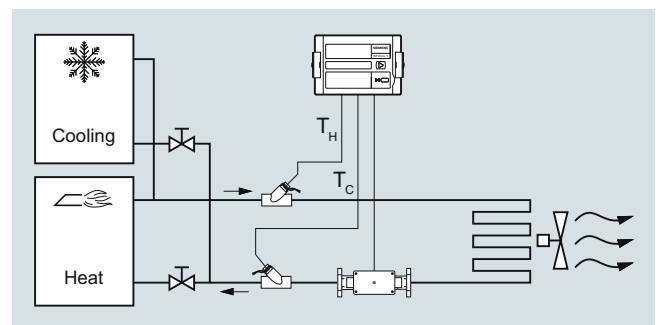

Design

SITRANS FUE950 has an easy-read 8-digit LCD display with associated pictograms for the various functions. As the display has been made for several applications, some figures/symbols not used for normal district heating applications will be shown.

SITRANS FUE950 has a push button for simple operation and provides user-friendly control via the various display menu loops. The display will always be configured for the application chosen, and for the selected display settings.

The integrator has an IP54 plastic housing and is designed for wall or panel mounting. The housing comes with prepared rubber gaskets cable entries for fast and easy installation.

Operation menu loop structure

The FUE950 display has six menu loops and the menus are numbered in the display from 1 to 6. Some display menus consist of two values (to maximum seven) that are shown alternately at 4-second intervals.

The main menu loop no. 1 with the current data, e.g. for energy, volume, flow rate and temperature, is preprogrammed as default setting.

In the combined heating/cooling configuration the menu loop no. 5 (tariff menu loop) will be activated additionally.

Display and output pulses

Units: MWh, GJ, Gcal, MBtu, m³, gal, m³/h, GPM, °C, °F and kW; all decimal points are statically (the unit "gal" is shown with factor x 100).

The display unit and the last fractional digit are typical used for the pulse outputs.

Function

Technical principle

Calculation of energy is based on the following formula:

$$\text{Energy} = \text{Volume} \times (T_{\text{Hot}} - T_{\text{Cold}}) \times K_{\text{factor}} (T_i)$$

Volume: Volume [m³] of a given amount of volume pulses

T_{Hot}: Measured temperature in the hot line

T_{Cold}: Measured temperature in the cold line

K_{factor} (T_i): Thermal coefficient of media enthalpy and heat content

The energy calculation is made by a counter and depends on temperature difference, pulse input frequency and legal requirements.

The calculator always carries out at least one energy calculation every 2 seconds. If the connected flowmeter has not sent enough pulses the energy calculation and flow indication is also based on the 8 seconds value.

Data memory

The FUE950 has a history memory of 24 periods (months, weeks, days). The following values are stored monthly, weekly or daily in the EEPROM on the programmed day of 1...31 (via software tool).

• Date/Time	• Volume
• Energy	• Error day counter
• Tariff energy 1	• Maximum monthly flow rate
• Tariff energy 2	• Maximum monthly power
• Tariff definition 1	• Date of maximum monthly flow rate
• Tariff definition 2	• Date of maximum monthly power
• Pulse counter input 1	• Pulse counter input 2
• Operation hours	

Data logger memory (LOG)

The LOG of the calculator is stored every 24 hours with all cumulative values in the EEPROM. The storage frequency can be selected from various storage intervals (5, 6, 10, 12, 15, 20, 30, 60 minutes or the default setting of 24 hours). The data which are stored in the LOG could be read out using a software tool and can be used for evaluations.

Extract of possible LOG settings

Storage interval	Values	Number of data records	Recording period
5 minutes	• Error status	440	36.6 hours
15 minutes	• Overload time temperature	440	110 hours
1 hour	• Overload time flow rate	440	18.3 days
24 hours (default setting)	• Forward temperature • Return temperature • Date and time • Energy • Tariff energy 1 • Tariff energy 2 • Tariff definition 1 • Tariff definition 2 • Volume • Error day counter	440	440 days

Maximal Values

The integrator creates max. values for power and flow rate based on consumption time, which are stored in the EEPROM. The integration intervals are adjustable to 6, 15, 30 or 60 minutes and 24h. Default setting is 60 minutes.

Tariff/Accounting date function

The calculator includes two independent memories in which the accumulated energy at two programmable tariff dates are stored.

- Last accounting date
- Last but one accounting date

Values stored

- Energy
- Volume
- Tariff counter 1
- Tariff counter 2
- Pulse counter 1
- Pulse counter 2
- Date

The integrator offers two optional tariff memories for monitoring plant load states. Here it concerns threshold value tariffs. Extensive tariff conditions make it possible to adapt the calculator individually to the required customer-specific applications.

Both tariffs are separately configurable and independent from each other. Energy or time can be measured alternatively per tariff register dependent on the tariff mode adjusted in each case.

With the "time triggered tariff function" the switch-on time and the switch-off time are adjustable independent from each other for each day of the week in steps of 15 minutes.

Flow Measurement

SITRANS F US Inline

SITRANS FUE950 energy calculator

The following tariff limit types of the tariff function are possible: (This example applies to the display at 1 fractional digits after comma)

Type	Description	Limit	Limit resolution
dT	Temperature difference	1 ... 190 °C	1 °C
-dT	Negative temperature difference	1 ... 190 °C	1 °C
TR	Return temperature (low)	1 ... 190 °C	1 °C
TV	Forward temperature (high)	1 ... 190 °C	1 °C
P	Power	10 ... 2 500 kW	10 kW
Q	Flow	1 ... 255 m ³ /h	1 m ³ /h
FE	"Theoretically forward energy" with return temperature of 0 °C		
Z	"Time triggered" counting energy		
E	"External" counting energy		

Error handling and memory

Events such as changes and faults are stored in a non-volatile memory with a capacity of up to 127 entries. The following events are recorded:

- Checksum error
- Temperature measurement error
- Error hours
- Start and end of test mode

If SITRANS FUE950 records an error, this will be automatically indicated by a "alarm symbol" on the display.

To protect the reading data, all the relevant data are saved in a non-volatile memory (EEPROM). This memory saves the measured values, device parameters and types of error at regular intervals.

The following events are recorded:

- Temperature sensor error
- Swapped hot and cold temperature sensors
- Battery low warning
- Power supply failure
- Optical communication warning
- RAM checksum error

Outputs/Inputs/Communication

Communication interfaces:

SITRANS FUE950 is fitted with an optical infra-red send/receive port in accordance with EN1434/IEC 61107, protocol standard, EN 1434/EN 60870-3 (M-Bus protocol).

A specific optical head with a permanent magnet (IrDA-adapter) in accordance with EN 1434 can be used for readout data or communication with the parameterization software.

2 ports for optionally plug-in modules

The calculator features 2 ports for the plug-in modules.

One slot is for the function modules and the other for the communication modules.

Communication modules

The following communication modules are available as options: RS 232 module, RS 485 module and M-Bus module. The RS 232 and RS 485 communication modules are serial interfaces and permit data exchange with the calculator. For this purpose a special data cable is necessary.

The M-Bus module is a serial interface for communication with external devices (M-Bus Master/Centre). According to the M-Bus structure a number of calculators can be connected to a control centre.

Pulse input module

Two pulse inputs are available. The pulse value and the unit is configurable for energy, water, gas or electrical meter by parameterization software. Data are separate cumulated in different registers and are also stored on the two accounting day's (Tariff registers).

Combined Pulse Input/Output module

Two pulse inputs combined with one pulse output are available on one module. The pulse inputs are configurable with value and the unit by parameterization software.

The pulse output is also programmable using the parameterization software.

Pulse output

The calculator provides levels for two optional external pulse outputs, which can be freely programmed using the parameterization software tool.

Default setting is one pulse which occurs per change in the least significant digit in the display with the unit and resolution selected by the device ordering.

Possible pulse output values

- Energy (default setting)
- Volume (default setting)
- Tariff energy 1
- Tariff energy 2
- Tariff condition 1, limit switch
- Tariff condition 2, limit switch
- Energy error
- Volume error
- Volume with specific resolution (0.1, 1.0, 10 or 100)
- Energy with specific resolution (0.1, 1.0, 10 or 100)

Combined current output module

Optional module with 2 passive 4 ... 20 mA outputs.

Possible output values:

- Power (default setting for output #1)
- Flow (default setting for output #2)
- Hot, cold or difference temperature

The settings can be configured by parameterization software. The current output module occupies both ports, means no other plug-in module will possible to plug in.

Module combinations

The calculator has a group of extension modules for communication and another group of extension modules for additional functionality. These modules are available first selected within the calculator, or for retrofitting in the field.

One single function module as well as one single communication module out of following modules is selectable.

Function modules:

- Pulse input module, 2 inputs
- Pulse output module, 2 outputs
- Combined pulse module 2 inputs, 1 output
- Combined current output module, 2 x passive 4 ... 20 mA (occupies both ports)

Communication modules:

- M-Bus (M-Bus protocol according EN 1434-3)
- RS 232 (M-Bus protocol according EN 1434-3)
- RS 485 (M-Bus protocol according EN 1434-3)

Integration

SITRANS FUE950 is a multi-purpose energy calculator for media water which meets the requirements of EN 1434. Further, the energy calculator has been specially developed to process volume pulses from SITRANS FUS380/FUE380 or alternatively MAG 5000/6000 or FST020 transmitter.

Technical specifications

Approval	MID approved in accordance with energy meter EN 1434 and PTB K7.2 (German national cooling approval)	
Approved temperature range		
• Heating	0 ... 180 °C (32 ... 356 °F)	
• Cooling	0 ... 105 °C (32 ... 221 °F)	
Absolute temperature range	-20 ... +190 °C (-4 ... -374 °F)	
Differential temperature		
• Heating	3 ... 177 K (starting at 0.1 K)	
• Cooling	3 ... 102 K	
Measuring accuracy	Meets requirements of EN 1434 Typically max. $\pm (0.5 + 3K/\Delta\Theta)$ [%] of measured value	
Measuring rates		
• Battery type D-cell	Volume: 1 s, temperature: 4 s	
• Mains versions	Volume: 1/8 s, temperature: 2 s	
Flow range	Depends on pulse input value (IN0), see "Selection and Ordering data".	
Power range value	Depends on pulse input value as follows:	
	Pulse input value (I/P or gal/P)	Max power [kW]
	1	15 000
	2.5	15 000
	5	15 000
	10	150 000
	25	150 000
	50	150 000
	100	1 500 000
	250 *)	1 500 000
	500 *)	1 500 000
	1 000 *)	15 000 000
	*) not available for gal/pulse	

Typical accuracy of FUE950

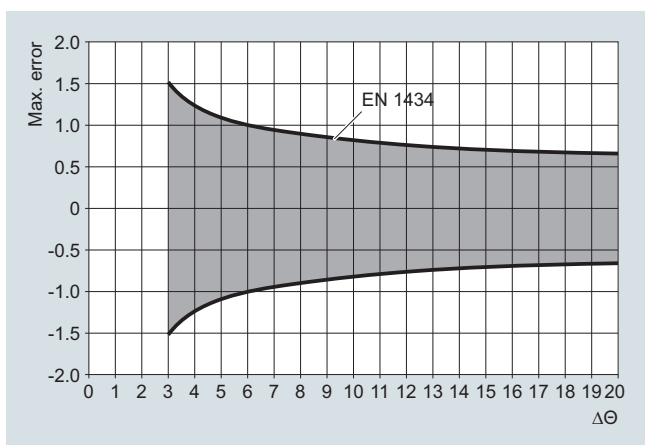

User interface (always included)

Display	8-digit LCD display with associated pictograms/symbols
Units	MWh, GJ, Gcal, MBtu, m ³ , m ³ /h, GPM, gal, °C, °F, kW, MBtu/h (gal is shown with factor x 100)
Totalizer value range	99 999 999 or 9 999 999.9 (0 and 1 digit after comma). Display digits: Flow in 6 digits; Volume, power and energy in 8 digits
Values	Power, energy, volume, flow rate, temperatures
Push button	Single push button for the menu controlling
Optical interface IrDA interface	ZVEI optical interface with M-Bus protocol as per EN 1434, connection via separate IrDA-adaptor baud rate: 300 or 2400

Rated operation conditions

Enclosure	IP54 in accordance with IEC 529
Material	
• Housing	C Lexan 141R (or similar); colors: light gray (top part) and black (bottom part)
• Pipe/wall fitting	PA 6.6 GF25 (or similar)
• Other plastic parts	ABS Cicolac GPM500 (or similar)
• Gaskets	Neoprene and rubber cable bushings: EPDM 50
• Rubber cable bushings	EPDM 50

Temperature	
• Ambient	5 ... 55 °C (41 ... 131 °F)
• Storage	-25 ... +70 °C (-13 ... +158 °F) Relative ambient humidity < 93 %
Environment class	
• Mechanic class	M1/M2
• Electromagnetic class	E1/E2 (MID) or C (DIN EN 1434)

Temperature input (always included)

Function	The temperature sensors must be connected to terminals 1-5 and 6-2 (TH) and 3-7 and 8-4 (TC) depending on cable type (2-wire or 4-wire).
Temperature range Absolute measuring range	-20 ... 190 °C (-4 ... 374 °F) for T _H and T _C
Temperature difference	Start 0.1 K, min. 3 K, max. 177 K
Measurement cut-off	0.125 K 16-bit digital resolution AD converter
Display resolution	T _H and T _C : 0.1 K, ΔT : 0.1 K
Sensor types	Pt100 or Pt500 as 2-wire or 4-wire; Standard is Pt500. Sensor cable length: up to 10 m (according EN 1434 and MID-type approval).
Sensor connection	4-wire or 2-wire; auto detection of connection version

Flow input (IN0) (always included)

Function	Used as standard for flow input of the external flowmeter. The input is marked as 10 (+ Flow Pulse), 11 (- Gnd) on the terminal strip. Note: The pulse input value selection must be the same as the pulse output setting of the flowmeter.
----------	--

Flow Measurement

SITRANS F US Inline

SITRANS FUE950 energy calculator

Pulse value	1 ... 1 000 l/pulse or 1 ... 100 gal/pulse, selection by corresponding Order code. Will be shown at the device label	Possible pulse output selection	<ul style="list-style-type: none"> • Energy (default setting for 'Out1') • Volume (default setting for 'Out2') • Tariff energy 1 • Tariff energy 2 • Tariff condition 1 (limit switch) • Tariff condition 2 (limit switch) • Energy error • Volume error • Volume with specific display resolution (or with factor 0, 1, 10 or 100 thereof) • Energy with specific display resolution (or factor 0.1 thereof)
Pulse frequency	≤ 100 Hz (200 Hz)		
Pulse ON-time	≥ 3 ms		
Pulse OFF-time	≥ 2 ms		
Type	Active pulse input		
Terminal voltage	3.6 V DC (supplied internally by FUE950)		
Flowmeter installation place	The flowmeter installation place can be in the hot line or cold line ("forward or return pipe") selected by corresponding Order code. The "installation place" will be shown at the device display and nameplate		
Connected cable	Max. 10 m (shielded cables are highly recommended)		
Ports for option modules			
Type	The calculator features 2 ports for optional plug-in modules.		
Function modules (Port 1 or 2)	<ul style="list-style-type: none"> • Pulse input module, 2 inputs (In1, In2) • Pulse output module, 2 outputs (Out1, Out2) • Combination module of 2 inputs (In1, In2) and 1 output (Out1) 		
Current output module (Port 1)	2 passive 4 ... 20 mA (#1, #2) (occupies both port 1 and 2)		
Communication modules (Port 1 or 2)	M-Bus, RS 232 or RS 485 (M-Bus protocol, according EN 1434-3)		
Pulse output			
Function	The module contains connections for 2 pulse outputs, which can be programmed as desired using a software tool. The pulse outputs are marked as standard as O1, 'gnd' and O2, 'gnd' on the terminal strip and Out1 respectively Out2 in the display.		
Type	Passive "open collector" pulse output, outputs potential isolated to each other		
Pulse value	Last significant digits of the display (unit/pulse), selection by corresponding Order code and setting can be read via display menu, settings changeable via software tool		
Pulse output 1			
• Pulse frequency	≤ 4 Hz		
• Pulse width	125 ms ± 10 %		
• Pulse duration	125 ms ± 10 %		
• Pulse break	≥125 ms -10 %		
Pulse output 2			
• Pulse frequency	≤ 100 Hz, depending on the selected pulse length		
• Ratio	Pulse duration/pulse break ~1:1		
Pulse length	5, 10, 50, 100 ms (default: 5 ms)		
External voltage supply	3 ... 30 V DC		
Current	≤ 20 mA with a residual voltage of ≤ 0.5 V		
		Pulse input	
		Function	Add-on module for two additional counters. The pulse input 1 is marked as I1, 'gnd' and the input 2 as I2, 'gnd' on the terminal strip and indicated in the display as separate registers IN1 and IN2 and can also be transferred via the communication modules.
		Type	Passive "open collector" pulse inputs, outputs not potential isolated to each other, data are separate cumulated in different registers and are also stored on the two accounting day's.
		Pulse value	Pulse value and the unit are configurable for energy, water, gas or electrical meter by a software tool Default: Pulse input 0.1 m ³ or 1 gal (if unit 'gal' is ordered with the Z-option "L05")
		Pulse frequency	≤ 8 Hz
		Pulse length	≥ 10 ms
		External voltage supply	3 V DC (supplied internally by FUE950)
		Current	based on R _i = 2.2 MΩ
		Cable length	< 10 m connection limit
		Current output module	
		Function	The module contains connections for 2 passive current outputs, which can be programmed individually using the software tool. The outputs are marked „#1" and „#2" with corresponding polarity „+" and „-" on the terminal strip. The module will be connected on port 1 only, but both ports are occupied by the module.
		Terminal voltage	External supply: 10 ... 30 V DC (passive output)
		Signal range	4 ... 20 mA; 4 mA = 0 value and 20 mA = default maximum values (for #1: Power in kW and for #2: Flow with the max. values and selected unit). Defaults: For power it is the max. selectable value x 100 000 the last digit of display (e. g. 20 mA = 10 000 kW (1 digit res.) or 100 000 kW (0 digit res.). For flow it is the max. selectable value x 10 000 the last digit of display (e. g. 20 mA = 1 000.0 m ³ /h (1 digit res.) or 10 000 m ³ /h (0 digit res.).

SITRANS FUE950 energy calculator

Load	Max. 800 Ω
Upper limit	Up to 20.5 mA (exceed causes the error current value)
Signal on alarm	Errors are indicated with 3.5 mA or 22.6 mA (programmable, default: 3.5 mA)
Output values	Power, flow, temperature (configuring via software tool; default: for #1: Power and for #2: Flow)

M-Bus output	
Type	The optional M-Bus plug-in module is a serial interface for communication with external devices (M-Bus Repeater)
Protocol	M-Bus according EN 1434-3
Connection	The connection is not polarity-conscious and is electrically isolated, connection of 2 x max. 2.5 mm ² wires, 300 or 2400 baud (auto baud detection), current drawn: one M-Bus load. M-Bus address: Each port has its own primary M-Bus address (Prim1 = the last two digits of the serial number; Prim2 = 0). The secondary address is unique for each calculator and is factory-set to equal the serial number.

RS 232 output	
Type	The optional module RS 232 is a serial interface for data transmission with external devices, e.g. PC; baud rate: 300 or 2400. The module contains a 3-pole terminal strip with terminals marked 62 (TX), 63 (RX) and 64 (GND). For this purpose a special data cable is necessary.
Protocol	M-Bus according EN 1434-3
Connection	The module contains a 3-pole terminal strip with terminals marked 62, 63, 64 (max. 2.5 mm ²); Connected cable length: max 10 m; For communication with a PC a special adapter cable is required (Article No. A5E02611774).

RS 485 output	
Function	The optional RS 485 module is a serial interface for data transmission with external devices, e.g. PC; baud rate: 2400. The module contains a 4-pole terminal strip with terminals marked D+, D-, Vcc and GND.
Protocol	M-Bus protocol according EN 1434-3
Connection	Terminals D+ and D-; electrically isolated; 2400 baud only. An external supply of 12 V DC ± 5 V (<5 W) is needed for the module (terminals Vcc and GND). The module terminals are max. for 2.5 mm ² wires. Connected cable length: max. 10 m

Power consumption	
230 V and 24 V versions	Typical current appr. 0.15 VA
3.6 V D-cell battery	Typical battery lifetime 10 years under normal conditions (no add-on modules, max. 40 °C ambient temperature)
Supply data	
Battery, 3.6 V type (option)	3.6 V lithium D-cell, battery lifetime typically 16 years with independently powered flowmeter
230 V AC module (option)	Plug-in module for 230 V AC (195 ... 253 V AC), 50/60 Hz (incl. battery backup)
24 V AC module (option)	Plug-in module for 24 V AC (12 ... 30 V AC) (incl. battery backup)
Battery backup (option)	Only with mains supply modules by internal 3.0 V lithium battery (type CR 2032) Displayed values, date and time are still updated, but the measuring functions have stopped, including the flow rate measurement. Communication via optional modules M-Bus, RS 485, RS 232 or optical interface is maintained, affecting the backup battery lifetime.

Accessories/Software

The parameterization software based on the M-Bus is a convenient tool for handling the calculator. It runs on Windows and is used for configuration of the calculator functionality, reading out different memories, printing out calculator logs. For further details please contact your local Siemens representative.

A specific optical head with a permanent magnet in (IrDA adapter with bluetooth) accordance with EN 1434 can be used for programming/altering programming of readout data, configuration data, etc. The reader head can also be used to change measuring data.

Dimensional drawings

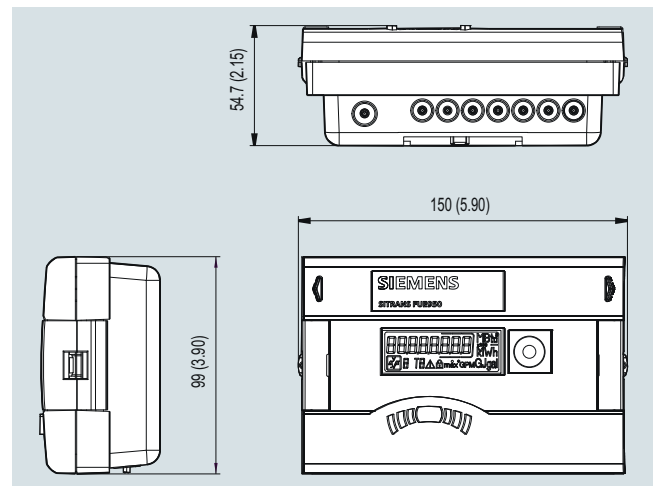

SITRANS FUE950, dimensions in mm (inch)

Flow Measurement

SITRANS F US Inline

SITRANS FUE950 energy calculator

3

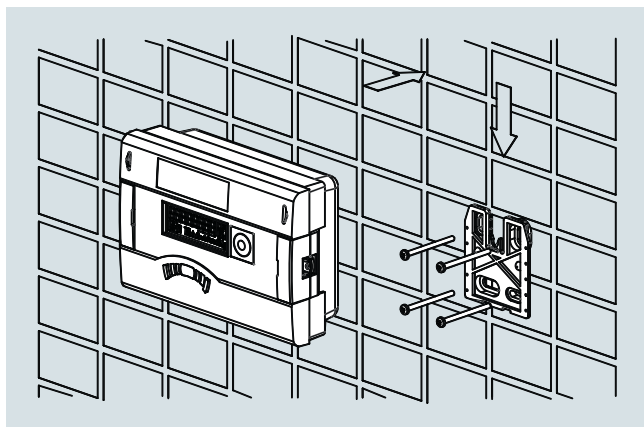

Wall mounting

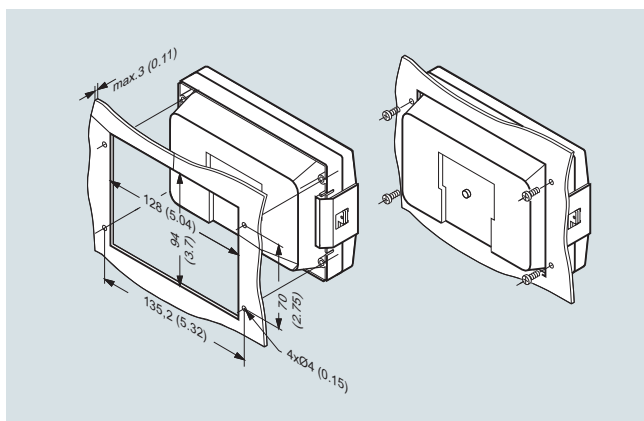

Panel mounting, dimensions in mm (inch)

Pt500 temperature sensor pairs

Application

The temperature sensor set is designed for use with the Siemens energy calculator type SITRANS FUE950 for measurement of the energy consumption in a district heating or cooling net.

Temperature sensors are one of the integral components of every thermal energy meter in heating or cooling applications. They are used for determining temperature changes in fluids due to energy taken from or supplied to the loop. The temperature is thus measured by mounting temperature sensors upstream and downstream from the point where the exchange in the thermal energy of the system is.

To ensure an accurate measurement of the temperature difference according to MID (EN 1434) or PTB K7.2 the sensors are delivered as matched pairs.

By selection with the corresponding Order code the Pt500 sensor pair sets can be delivered with heating approval or with approvals for combined heating/cooling applications.

Technical specifications

Temperature sensor pairs:

2-wire Pt500

Pt500 2-wire temperature sensor pair (EN 1434)	
Measuring insert	Pt500 temperature sensor, EN 60751, tolerance class B, 2-wire
Pairing	Paired to EN 1434 (10 ... 130 °C/14 ... 266 °F)
Media temperature	0...150 °C (32 ... 302 °F)
Response time $T_{0,5}$	See sensor pocket specifications
Medium	Typically heating water
Pressure rating	See sensor pocket specifications
Protection	IP65
Pipe material	AISI 304Ti/1.4303
Dimension	Ø 6 mm
Sensor tube length	50 mm
Cable length	Up to 10 m (32.8 ft), fixed connected silicon cable, 2 connection wire terminals, terminal sleeves to DIN 46228

4-wire Pt500

Pt500 4-wire temperature sensor pair (with MID and PTB K7.2 approval)	
Measuring insert	Pt500 temperature sensor, EN 60751, tolerance class to ISO 751 Class B; 4-wire
Pairing	Matched paired according to EN 1434 at 10, 75 and 140 °C (50, 167 and 284 °F)
Type approval	MID (DE-06-MI004-PTB011) and PTB K7.2 (PTB 22.77/09.01). Only to be mounted with related sensor pockets according to the type approvals.
Media temperature	0...150 °C (32 ... 302 °F)
Permissible temp. pair range for ΔT	<ul style="list-style-type: none"> • Heating 3 ... 150 K • Cooling 3 ... 85 K
Medium	Approved for heating/cooling water
Protection	IP65
Environment	<ul style="list-style-type: none"> • Mechanic class M3 • Electromagnetic class E1 (MID)
Pressure rating	See sensor pocket specifications
Material	<ul style="list-style-type: none"> • Protective tube Stainless steel AISI 304Ti/1.4571 (or similar), diameter of protective tube: 6 mm • Connector cable Silicon cable, 4 connection wire terminals, terminal sleeves to DIN 46228
Sensor tube length	140 or 230 mm (5.51 or 9.06 inch)
Cable length	5 m (16.4 ft), fixed connected

Sensor pockets

Stainless steel sensor pocket (for 4-wire Pt500 types only - standard)

Media temperature	0 ... 150 °C (32 ... 302 °F)
Approval	Approved only together with 4-wire sensors
Medium	Approved for heating/cooling water; up to max. 5 m/s flow velocity
Pressure rating	PN 40
Length	Face-to-face length 120/135 and 210/225 mm (4.72"/5.23" and 8.27"/8.86")
External diameter	Protective tube 8/11 mm (0.32"/0.43")
Internal diameter	Protective tube 6 mm (0.24")
Pipe connection	Thread G 1/2" (with sealing screw for sensor)
Material	Protective tube AISI 316Ti/1.4571 (or similar)
Use	<ul style="list-style-type: none"> Use with related 4-wire Pt500 sensors only (according type approval) For flow velocities up to 5 m/s Recommended to install with welded sleeve (according to EU standard)

Stainless steel sensor pocket (for 2-wire Pt500 types only - some only available as spare part)

Media temperature	0 ... 180 °C (32 ... 356 °F)										
Medium	Approved for heating water										
Response time $T_{0.5}$	Typically 13 s at 0.4 m/s without pasta Typically 5 s at 0.4 m/s with pasta										
Pressure rating	PN 25										
Length	<table border="1"> <tr> <td>L1 (mm)</td> <td>92</td> <td>127</td> <td>168</td> <td>223</td> </tr> <tr> <td>L (mm)</td> <td>82</td> <td>117</td> <td>155</td> <td>210</td> </tr> </table>	L1 (mm)	92	127	168	223	L (mm)	82	117	155	210
L1 (mm)	92	127	168	223							
L (mm)	82	117	155	210							
Material	Stainless steel: AISI 316Ti/1.4571										
Use	For 2-wire Pt500 types only										

Brass sensor pocket (for 2-wire Pt500 types only - some only available as spare part)

Media temperature	0 ... 150 °C (32 ... 302 °F)								
Medium	Approved for heating water								
Response time $T_{0.5}$	Typically 9 s at 0.4 m/s without pasta Typically 5 s at 0.4 m/s with pasta								
Pressure rating	PN 16								
Length	<table border="1"> <tr> <td>L1 (mm)</td> <td>47</td> <td>92</td> <td>127</td> </tr> <tr> <td>L (mm)</td> <td>40</td> <td>82</td> <td>117</td> </tr> </table>	L1 (mm)	47	92	127	L (mm)	40	82	117
L1 (mm)	47	92	127						
L (mm)	40	82	117						
Material	Brass: CuZn ₄₀ Pb ₂ (Ms58)								
Use	For 2-wire Pt500 types only								

Dimensional drawings

Pt500 2-wire temperature sensor pair (EN 1434)

Cable length 2, 3, 5 or 10 m ('C' at the dimensional drawing)

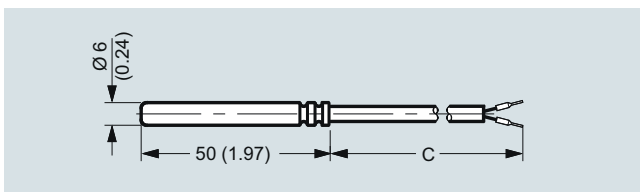

Pt500 2-wire temperature sensor, dimensions in mm (inch)

Pt500 4-wire temperature sensor pair (with MID and PTB K7.2 approval)

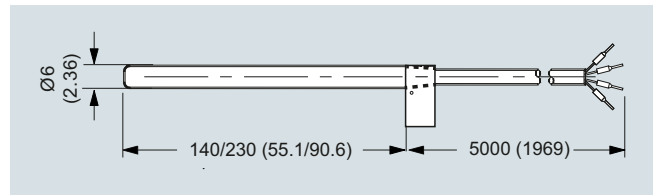

Pt500 4-wire temperature sensor, dimensions in mm (inch)

Stainless steel sensor pocket (for 2-wire Pt500 types only)

Length	L1 (mm)	92	127	168	223
	L (mm)	82	117	155	210

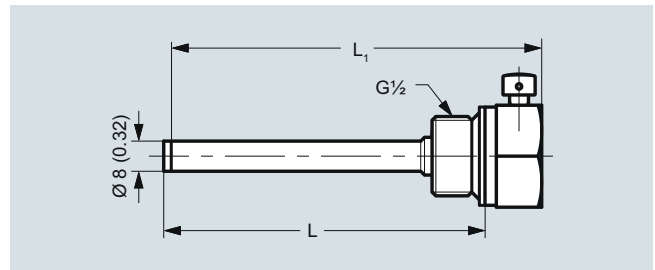

Sensor pocket (for 2-wire Pt500 types only), stainless steel, dimensions in mm (inch)

Stainless steel sensor pocket (for 4-wire Pt500 types only)

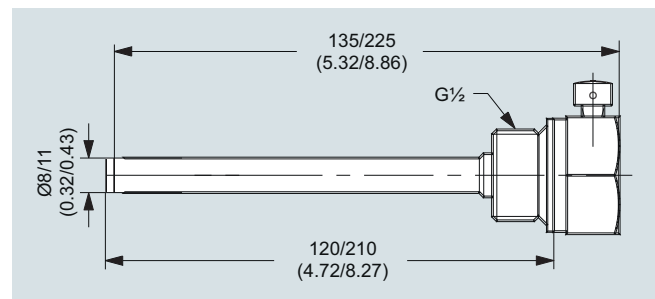

Stainless steel sensor pocket, dimensions in mm (inch)

Brass sensor pocket (for 2-wire Pt500 types only)

Length	L1 (mm)	47	92	127
	L (mm)	40	82	117

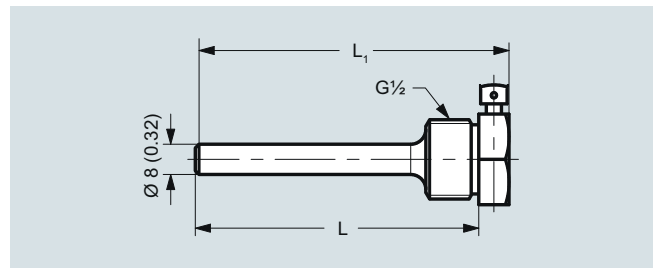

Sensor pocket, brass (for 2-wire Pt500 types only), dimensions in mm (inch)

Flow Measurement

SITRANS F US Inline

SITRANS FUE950 energy calculator

Selection and Ordering data

Article No.

Order code

Energy calculator SITRANS FUE950, MID or PTB K7.2 custody transfer approved



7ME3480 -

Click on the Article No. for the online configuration in the PIA Life Cycle Portal.

Flow input setting (IN0)

The pulse input value selection must be the same as the pulse output setting of the selected flowmeter. To get optimal function and performance the pulse value must be selected as low as possible according to the maximum flow rate.

The following calculation formula can be used for determining the lowest pulse value at a pulse length of 5 ms: $L/\text{pulse} > Q_{\max} (\text{m}^3/\text{h})/360$.

For example $Q_{\max} = 300 \text{ m}^3/\text{h}$; $L/\text{pulse} > 300/360$; $L/\text{pulse} > 0.83$; therefore the pulse value must be 1 l/pulse.

Pulse input in l/pulse or in gal/pulse (with option L05)	Flow limit Q_{\max} in m^3/h	Flow limit Q_{\max} in GPM *) (with option L05)
1	360	6 000
2.5	900	15 000
5	1 800	30 000
10	3 600	60 000
25	9 000	150 000
50	18 000	300 000
100	36 000	600 000
250	90 000	-
500	180 000	-
1 000	360 000	-

*) GPM = Gallons per minute

Calculator application/Flowmeter installation place

For heating, flowmeter in return pipe (cold pipe), typical standard

For heating, flowmeter in forward pipe (hot pipe)

For cooling, media water, flowmeter in forward pipe (cold pipe)

For cooling, media water, flowmeter in return pipe (hot pipe)

For combined cooling/heating, flowmeter in forward pipe (hot pipe as heating) (MID conformity declaration for heating)

For combined cooling/heating, flowmeter in return pipe (cold pipe as heating) (MID conformity declaration for heating)

Temperature sensor type

Pt500 setup, no sensor pair included (standard)

Pt500 setup and Pt500 sensor pair (6/140 mm), 4-wire with 5 m connection cable, 6 mm sensor diameter and 140 mm sensor length. MID approved DE-06-MI004-PTB011, PTB approved 22.77/09.01, incl. factory test report (mentioned approvals are only valid if temp. sensors are used with the applicable temperature sensor pockets).

Pt500 setup and Pt500 sensor pair (6/230 mm), 4-wire with 5 m connection cable, 6 mm sensor diameter and 230 mm sensor length. MID approved DE-06-MI004-PTB011, PTB approved 22.77/09.01, incl. factory test report (mentioned approvals are only valid if temp. sensors are used with the applicable temperature sensor pockets).

Pt100 setup, no sensor pair included

Pt 500 setup and PT500 sensor pair (6/50 mm), 2-wire type incl. 5 m cable, 6 mm sensor diameter and 50 mm length, with MID approval (only for use with the applicable temperature sensor pockets)

Pt 500 setup and PT500 sensor pair (6/50 mm), 2-wire type incl. 10 m cable, 6 mm sensor diameter and 50 mm length, with MID approval (only for use with the applicable temperature sensor pockets)

Temperature sensor pocket sets: (for 6 mm sensor diameter)

No pockets (standard)

Brass pockets for 6 mm 2-wire sensors, length 82/92 mm, G $\frac{1}{2}$ inch, max. PN 16 (2 pcs.)

Stainless steel pocket, 120/135 mm length for 6 mm sensor diameter, max. PN 40 and max. 5 m/s (2 pcs. for 140 mm 4-wire sensors above)

Stainless steel pockets for 6 mm 2-wire sensors, length 117/127 mm, G $\frac{1}{2}$ inch, max. PN 25 (2 pcs.)

Stainless steel pocket, 210/225 mm length for 6 mm sensor diameter, max. PN 40 and max 5 m/s (2 pcs. for 230 mm 4-wire sensors above)

Stainless steel pockets for 6 mm 2-wire sensors, length 155/168 mm, G $\frac{1}{2}$ inch, max. PN 25 (2 pcs.)

Voltage supply

Battery 3.6 V DC (Lithium D-cell type) (standard)

Mains power module for 230 V AC supply (incl. back-up battery)

Mains power module for 24 V AC supply (incl. back-up battery)

No power supply module (power supply ordering separate)

2 A
2 B
2 C
3 A
3 B
3 C
4 A
4 B
4 C
5 A

A
B
C
D
E
F

0
3
4
5
6
7

0
2
5
6
7
8

1
2
3
4

Selection and Ordering data	Article No.	Order code
Energy calculator SITRANS FUE950, MID or PTB K7.2 custody transfer approved	7ME3480 -	
Option modules		
No module (standard)		A
<u>1 module (communication module)</u>		
M-Bus module		B
RS 232 module (M-Bus protocol)		C
RS 485 module (M-Bus protocol)		D
<u>1 module (function module)</u>		
Pulse output, 2x output (Out1 "Energy" and Out2 "Volume")		E
Pulse input, 2x input (In1 and In2)		F
Pulse out-/input combination, 2x input and 1x output		G
<u>Combination of 2 modules (communication and function module)</u>		
M-Bus module and Pulse output, 2x output (Out1 "Energy" and Out2 "Volume")		H
M-Bus module and Pulse input, 2x input (In1 and In2)		J
M-Bus module and Pulse out-/input combination, 2x input and 1x output		K
RS 232 module (M-Bus) and Pulse output, 2x output (Out1 "Energy" and Out2 "Volume")		L
RS 232 module (M-Bus) and Pulse input, 2x input (In1 and In2)		M
RS 232 module (M-Bus) and Pulse out-/input combination, 2x input and 1x output		N
RS 485 module (M-Bus) and Pulse output, 2x output (Out1 "Energy" and Out2 "Volume")		P
RS 485 module (M-Bus) and Pulse input, 2x input (In1 and In2)		Q
RS 485 module (M-Bus) and Pulse out-/input combination, 2x input and 1x output		R
Combination current output module, 2x passive 4 ... 20 mA (Out 1 "Power", Out 2 "Flow") (occupies both module Ports 1 and 2)		S
Display units and resolutions		
MWh & kW, m ³ , m ³ /h in 2 digit resolution; Temperature: no decimal figures		C
MWh & kW, m ³ , m ³ /h in 1 digit resolution; Temperature: no decimal figures		D
MWh & kW, m ³ , m ³ /h in 0 digit resolution; Temperature: no decimal figures		E
GJ & kW, m ³ , m ³ /h in 2digit resolution; Temperature: no decimal figures		H
GJ & kW, m ³ , m ³ /h in 1 digit resolution; Temperature: no decimal figures		J
GJ & kW, m ³ , m ³ /h in 0 digit resolution; Temperature: no decimal figures		K
Gcal & kW, m ³ , m ³ /h in 2 digit resolution; Temperature: no decimal figures		M
Gcal & kW, m ³ , m ³ /h in 1 digit resolution; Temperature: no decimal figures		N
Gcal & kW, m ³ , m ³ /h - in 0 digit resolution; Temperature: no decimal figures		P
MBTU & MBTU/h, m ³ , m ³ /h in 2 digit resolution; Temperature: no decimal figures		Q
MBTU & MBTU/h, m ³ , m ³ /h in 1 digit resolution; Temperature: no decimal figures		R
MBTU & MBTU/h, m ³ , m ³ /h - in 0 digit resolution; Temperature: no decimal figures		S
Verification/Approval		
Without type approval mark, neutral label (standard))		0
With MID type approval mark (only for heating combinations, selection "A, B, E and F")		1
With MID approval mark and first MID verification (only for heating, selection A, B, E and F")		2
Cooling approval mark, German national cooling approval according PTB-TR-K7.2 (only for cooling and media water, selection "C and D")		7
Cooling approval mark, German national cooling approval according PTB-TR-K7.2 and first verification (only for cooling and media water, selection "C and D")		8
Further designs		
Please add "-Z" to Article No. and specify Order code		
Certificate		
Including factory test report (certificate) of FUE950	ALWAYS INCLUDED	
Cooling, setup for non water		
Water/glycol setting for media type "Tyfocor LS (R)" (only with neutral label, no verification and approval)		C 0 2
Optional settings/programming		
Tariff function settings (specify in clear text, up to max. 20 characters)		D 0 2
Pulse output setting of option module (specify in clear text, up to max. 20 characters)		D 0 6
Pulse input setting of option module (specify in clear text, up to max. 20 characters)		D 0 8
Pulse input setting of 4 ... 20 mA option module (please specify 20 mA related type and value in clear text, up to max. 20 characters)		D 1 0
Special display units		
Flow in 'GPM' and Volume in 'gal' (x100) (digits/resolution as selected above, only with 0 digit resolution)		L 0 5
Temperature in deg. F (digit resolution as selected above)		L 3 1

Flow Measurement

SITRANS F US Inline

SITRANS FUE950 energy calculator

Flowmeter SITRANS FUE950 operating instructions, accessories and spare parts

Operating instructions

Description	Article No.
• English	A5E03424739

All literature is available to download for free, in a range of languages, at www.siemens.com/processinstrumentation/documentation

Accessories

Description	Article No.
Infrared optical head (Bluetooth type) for data acquisition & programming of FUE950	A5E02611768
Bracket for SITRANS FUE950 wall mounting (20 pcs.)	A5E02611769
Cable for data acquisition via RS 232 PC/D-sub 9F/3 wire	A5E02611774

Spare parts

Description	Article No.
Add-on modules for FUE950 (only for 7ME348 versions)	
Pulse input module (2 inputs)	A5E03461432
Pulse output module (2 outputs)	A5E03461436
Combined pulse in-/output module (2 inputs and 1 output)	A5E03461437
RS 232 module (M-Bus protocol)	A5E03461459
RS 485 module (M-Bus protocol)	A5E03461512
M-Bus module	A5E03461516
Combined current output module, 2 x passive 4 ... 20 mA	A5E03461583
Connection cable for option modules (types: Pulse, RS 232/RS 485, M-Bus, mA) (special connection cable with 2 plugs)	A5E03461585
Power supply for FUE950 (only for 7ME348 versions)	
3.6 V D-cell battery for SITRANS FUE950	A5E03461708
230 V AC supply module (incl. internal fuse T50 mA L 250 V and back-up battery) for SITRANS FUE950	A5E03461717
24 V AC supply module for SITRANS FUE950, incl. back-up battery	A5E03461719
Pocket for temperature sensors Pt500 (for related 4-wire Pt500 type only, 1 pc.)	
Stainless steel pocket (1 pc.), 135 mm length for 6 mm sensor diameter, max. PN 40 and max. 5 m/s (recommended for 140 mm sensor length).	A5E03462868
Stainless steel pocket (1 pc.), 225 mm length for 6 mm sensor diameter, max. PN 40 and max. 5 m/s (recommended for 230 mm sensor length).	A5E03462870

Description	Article No.
Pt500 4-wire temperature sensor pair, with MID MI004 and PTB K7.2 approvals and verification (for related 4-wire sensor pocket types only)	
Pt500 sensor pair (6/140 mm), 4-wire with 5 m connection cable, 6 mm sensor diameter and 140 mm sensor length. MID approved DE-06-MI004-PTB011, PTB approved 22.77/09.01 (mentioned approvals are only valid if temp. sensors are used with the applicable temperature sensor pockets).	A5E03462872
PT500 sensor pair (6/230 mm), 4-wire with 5 m connection cable, 6 mm sensor diameter and 230 mm sensor length. MID approved DE-06-MI004-PTB011, PTB approved 22.77/09.01 (mentioned approvals are only valid if temp. sensors are used with the applicable temperature sensor pockets).	A5E03462878
FUE950 enclosure (only for 7ME348 versions)	
Bottom part of FUE950 enclosure (1 pc.)	A5E03461508
Snap fit for FUE950 enclosure (1 pc.)	A5E30461731
Pocket for Pt500 temperature sensors (for corresponding 2-wire Pt500 types only, 1pc.)	
Brass pocket 6 mm, G½B x 40 mm (PN 16), 1 pc.	A5E02611778
Brass pocket 6 mm, G½B x 85 mm (PN 16), 1 pc.	A5E02611779
Brass pocket 6 mm, G½B x 120 mm (PN 16), 1 pc.	A5E02611780
Stainless steel 6 mm, G½B x 85 mm (PN 25), 1 pc.	A5E02611781
Stainless steel 6 mm, G½B x 120 mm (PN 25), 1 pc.	A5E02611783
Stainless steel 6 mm, G½B x 155 mm (PN 25), 1 pc.	A5E02611792
Stainless steel 6 mm, G½B x 210 mm (PN 25), 1 pc.	A5E02611793
Pt500 temperature sensor pair, 2-wire cable, 6 mm sensor diameter, with MID/EN-approval (for corresponding 2-wire sensor pocket types only)	
Cable length:	
2 m	A5E02611794
3 m	A5E02611795
5 m	A5E02611796
10 m	A5E02611798

Schematics

Electrical connection for SITRANS FUS380/FUE380/FUE950 and MAG 5000/6000/FUE950

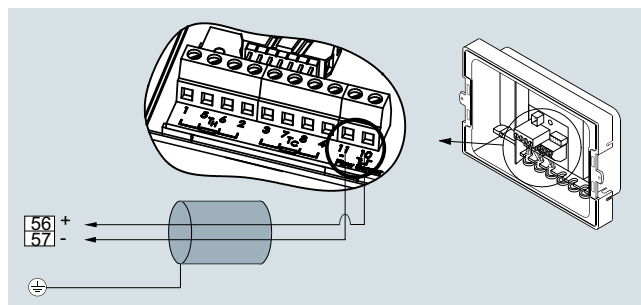

The diagram shows the connection between SITRANS FUE950 (terminals 10 and 11) and FUS380/FUE380 and MAG 5000/6000 (terminals 56 and 57). Temperature sensors must be connected to terminals 5 (1) and 6 (2) (T_H) and 7 (3) and 8 (4) (T_C).

Note:

The right flowmeter pulse output value must be equal to the FUE950 pulse input value and must be checked via the user menu of the transmitter MAG 5000/6000 or nameplate of FUE380 or FUS380.

Overview



SITRANS F S clamp-on ultrasonic flowmeters provide highly accurate measurement while minimizing installation time and maintenance expense.

Benefits

- Easy installation; no need to cut pipe or stop flow
- Minimal maintenance; external sensors do not require periodic cleaning
- No moving parts to foul or wear
- No pressure drop or energy loss
- Wide turn-down ratio
- Choice of single and dual path versions to suit your operating conditions and requirements.

System performance

Pending approvals	<ul style="list-style-type: none"> • ATEX Zone 2 • IECEx Zone 2 • FM Class I Div. 2 • FMc Class I Div. 2
Accuracy	± 0.5 ... 1 % for velocities above 0.3 m/s and >10 diameters straight run
Repeatability	± 0.25 % (based on ISO 11631)
Pipe size range	12.7 ... 10 m (0.5 ... 394")
Wall Thickness Range	0.64 ... 76.2 mm (0.025 ... 3.0")
Pipe material	Any sonically conductive material (steel, plastic, aluminum, glass, cement, ductile iron, copper)

Applications

SITRANS FS230 standard functions are suitable for a wide variety of liquid applications, including the following:

- Water industry
 - Raw water
 - Potable water
 - Chemicals
- Wastewater industry
 - Raw sewage
 - Effluent
 - Sludges
 - Mixed liquor
 - Chemicals
- HVAC industry
 - Condensers
 - Hot and cold water systems
- Power industry
 - Nuclear
 - Fossil
 - Hydroelectric
- Processing industry
 - Process control
 - Batching
 - Rate indication
 - Volumetric and mass measurement

SITRANS FS230 hydrocarbon functions are ideal for applications carrying crude oil, refined petroleum or liquefied gas.

Standard volume (high end system)

- Standard (net) volume flow measurement
- Suitable for use in leak detection systems
- Mass flow output measurement
- Chemical and petrochemical processing
- Precise identification of interfaces on multi-liquid pipelines
- Product identification
- Standard density indication
- Applications with multiple liquids having a wide viscosity range
- Automatic gross volume compensation due to viscosity

Flow Measurement

SITRANS F S Clamp-on

System information SITRANS F S Clamp-on ultrasonic flowmeters

System information and selection guide

SITRANS F S clamp-on flowmeters	FS230 (Standard)	FS230 (Hydrocarbon)
Industry/Applications		
Water and aqueous solutions	X	
Utility district heating, cooling	X	
Chemical	X	
Hydrocarbons/petrochemical, multiple products or varying viscosity, liquefied gases, net and gross volume		X
Hydrocarbons (single product with limited viscosity range) gross volume	X	X
Very low flow (< 0.1 m/s) in small pipes	X	
High temperature applications < 232 °C (450 °F)	X	X
Refrigeration liquids	X	
Food products	X	
Design		
Field clamp-on (non-intrusive)	X	X
Standard volume or mass flow; per API MPMS chapter 11.1		X
Interface detection		X
Standard density output		X
Temperature measurement	X	X
Analog input	X	X
Large graphical display	X	X
Configuration and diagnostic software PDM compatible	X	X
Number of acoustic paths and channels		
1-path	X	X
2-path	X	X
Size		
12.7 ... 10000 mm (0.5" ... 394")	X	
38 ... 10000 mm (1.5" ... 394")		X
Pending approvals		
FM/FMc ¹⁾	X	X
ATEX	X	X
UL/ULc	X	X
IECEX	X	X

¹⁾ NEMA 4X associated equipment in DIV 2 connected to DIV 1 sensors.

Function

Operating Principle

The SITRANS F S system is a transit-time ultrasonic meter that provides exceptional performance using a non-intrusive clamp-on approach. Ultrasonic sensors transmit and receive acoustic signals directly through the existing pipe wall, where the fluid refraction angle is governed by Snell's law of refraction.

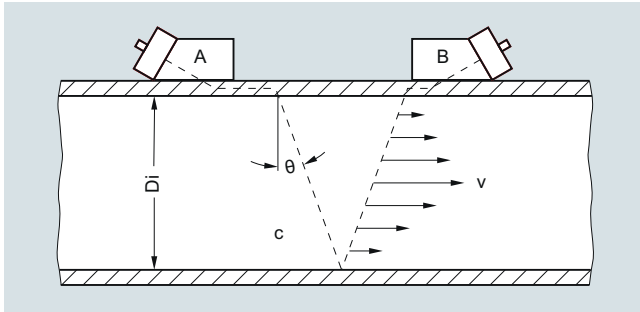

Clamp-on sensor mounted in a reflect configuration

The beam refraction angle is calculated as follows:

$$\sin\theta = c / V_{\phi}$$

c = Velocity of sound in fluid

V_{ϕ} = Phase velocity (a constant in the pipe wall)

The flowmeter automatically compensates for any change in fluid sound velocity (or beam angle) in response to variations in the average transit time between sensors A and B. By subtracting the computed fixed times (within the sensors and pipe wall) from the measured average transit time, the meter can then infer the required transit time in the fluid (T_{Fluid}).

The sound waves traveling in the same direction as the flow ($T_{A,B}$) arrive earlier than sound waves traveling against the direction of flow ($T_{B,A}$). This time difference (Δt) is used to compute the line integrated flow velocity (v) as shown in the equation below:

$$v = V_{\phi} / 2 \cdot \Delta t / T_{\text{Fluid}}$$

Once the raw flow velocity is determined, the fluid Reynolds Number (Re) must be determined to properly correct for fully developed flow profile. This requires the entry of the fluid's kinematic viscosity (visc) as shown in the equations below, where Q represents the final flow profile compensated volumetric flow rate.

$$Re = Di \cdot v / \text{visc} \cdot Q = K(Re) \cdot (\pi / 4 \cdot Di^2) \cdot v$$

v = Flow velocity

$\text{visc} = \mu / \rho$ = (dynamic viscosity / density)

$K(Re)$ = Reynolds flow profile compensation

In wetted type ultrasonic flowmeters the meter constants are configured prior to leaving the factory. As this is not possible with clamp-on meters, the settings must be made by the customer at the time of installation. These settings include pipe diameter, wall thickness, liquid viscosity, etc.

SITRANS clamp-on flowmeters that include temperature sensing can be configured to dynamically infer changes in fluid viscosity for the purpose of computing the most accurate flow profile compensation (K_{Re}).

Ultrasonic sensor types

Two basic types of clamp-on sensors can be selected for use with the SITRANS F S flowmeter. The lower cost "universal" sensor is the most common type in the industry and is suitable for most single liquid applications where the sound velocity does not vary much. This sensor type can be used on any sonically conductive pipe material (including steel) making it well suited for portable survey applications. Universal sensors are selected

based on the pipe diameter range alone, so wall thickness is less important to the selection process.

The second sensor type is the "WideBeam" sensor (called high precision), which utilizes the pipe wall as a kind of waveguide to optimize the signal to noise ratio and provide a wider area of vibration. This makes this kind of sensor less sensitive to any change in the fluid medium.

The WideBeam sensor is designed for steel pipes, but can also be used with aluminum and titanium. It is the preferred sensor for HPI applications. Note that unlike the universal type, this sensor selection is dependent only on the pipe's wall thickness.

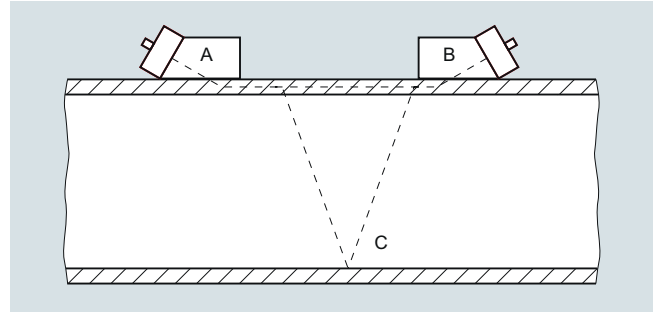

Multi-path flowmeters

For improved flow profile averaging, redundancy or better cost per measurement, clamp-on meters can be supplied with 1 or 2 path measurement systems.

In the standard FS230 systems, these can be installed on a single pipe as shown below (two paths on same pipe).

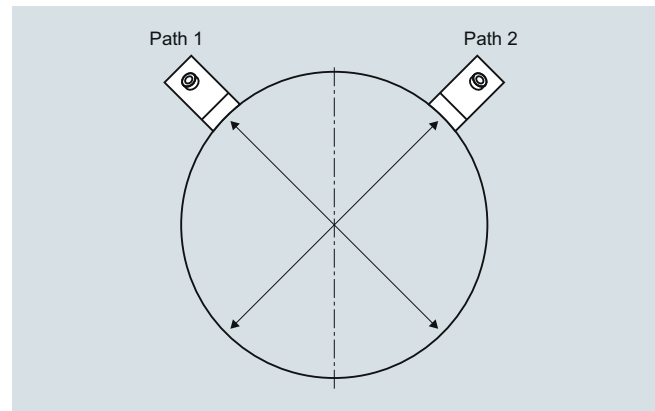

Dual path installation example

Flow Measurement

SITRANS F S Clamp-on

Ultrasonic flow sensor SITRANS FSS200

SITRANS meter family description

SITRANS FS230 clamp-on flowmeters

The FS230 system is a basic function, permanent (or dedicated) Clamp-on meter that is available with a full range of safety approvals and I/Os. This meter can be used in a wide range of applications.

FST030 transmitter standard flow functions

When configured with standard flow functions, the FST030 transmitter is typically programmed with a fixed viscosity and specific gravity entry, which can limit the mass flow and volumetric flow accuracy when highly variable (multi-product) liquid properties flow through the same pipeline.

It will have the ability to accommodate clamp-on RTDs, or analog input from a temperature transmitter.

FST030 hydrocarbon flow functions

When configured with hydrocarbon functions, the FST030 can be used for applications that will flow a wide range of viscosity with a standard volume (mass) and interface detection functions available. All functions rely on a variable referred to as "Liquident (TM)", which is used to infer the liquid's viscosity and density. This variable represents the measured liquid sonic velocity compensated by the operating temperature and pressure, so for a given liquid product the measured Liquident (TM) output will remain constant over a wide range of pressure or temperature.

Standard volume description:

This Liquident (TM) variable can also be used to identify the liquid flowing through the pipe as well as its physical properties (density, viscosity and compressibility) at base conditions. With this information the meter can be configured to output a temperature and pressure compensated (standard) volume flow rate using the API MPMS chapter 11.2.1 methods as shown below.

Correction for temperature:

Compute thermal expansion coefficient (α_b):

$$\alpha_b = KO / \rho_b^2 + K1 / \rho_b$$

where: KO and K1 are constants dependent on type of liquid and ρ_b is the liquid density at base conditions

Compute temperature correction factor (K_T):

$$K_T = \rho_b * \text{EXP}(-\alpha_b \Delta T (1 + 0.8 \alpha_b \Delta T))$$

where: $\Delta T = (T - \text{base temperature})$

Correction for pressure:

Compute compressibility factor (F):

$$F = \text{EXP}(A + B T + (C + D T) / \rho_b^2)$$

where: A, B, C and D are constants, and "T" is liquid temperature

Compute pressure correction factor (K_p):

$$K_p = 1 / (1 - F (P_{\text{act}} - P_{\text{base}}) * 10^{-4})$$

Final volume correction: $Q_{\text{std}} = Q_{\text{act}} * K_t * K_p$

Available outputs from this meter include: API, standard density, mass flowrate, standard volume flowrate and liquid identification.

General installation guidelines for transit time clamp-on sensor

- Minimum measuring range: 0 to ± 0.3 m/s velocity (see meter accuracy graph below for more detail)
- Maximum measuring range: 0 to ± 12 m/s (± 30 m/s for high precision sensors). Final flow range determination requires application review

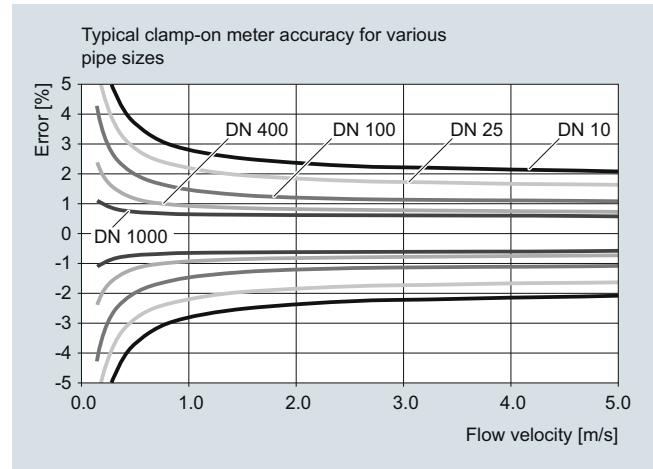

- Pipe must be completely full within the sensor installation volume for accurate flow measurement
- Typical MINIMUM straight pipe requirements are: 10 Diameters upstream/5 Diameters downstream. Additional straight run is required for double out-of-plane elbows and partially open valves.
- Sensors should be installed at least 20° off vertical for horizontal pipes. This reduces the chance of beam interference from gas buildup at the top of the pipe
- Operation inside the Reynolds transition region, between $1000 < Re < 5000$ should be avoided for best accuracy
- Submersible and direct burial installations can be accommodated. Consult sales representative for details
- Ultrasonic coupling compound is provided with all sensor orders. Insure that a permanent coupling compound is used for long term installations
- Refer to the "Sensor type selection guide" to insure proper application of the equipment

Sensor type selection guide



Standard sensor supported in MLFB

Considerations for sensor selection	High precision	Universal	Notes
Media			
General survey (clean liquids) on non-steel pipes		X	
General survey (clean liquids) on a limited range of steel pipes	X		
Moderately aerated liquid or slurry, up to 121 °C (250 °F)	X		
Permanent installation on steel pipe (clean liquids)	X		
Installation in offshore or corrosive environment	X ¹⁾	X ²⁾	Sensor size C/D/E come standard as corrosion resistant. Size A and B optional stainless steel
Liquid temperature greater than 120 °C (248 °F)	O	X	FSS200 high temperature metal block sensors (up to 232 °C (450 °F))
Operation on single pipeline flowing multiple products	X	O	
Pipe material			
Steel	X		
Steel pipe with diameter/wall thickness ratio <10	O	X	
Non-steel pipe material (copper, ductile iron, cast iron, etc.)	O	X	High precision sensors can also be used on plastic and aluminum pipes in special cases
Wall thickness > 31.75 mm (1.25")	O	X	

O = not suitable X = preferred choice

¹⁾ For steel and stainless steel pipes only

²⁾ Not preferred for steel pipes

Definitions

Sensor chart	Description
FSS200	Formerly 1011 clamp-on sensors of the 1010 systems
Standard	Standard system sensor, selectable as part of a configured product
Special	Sensors available for non-standard applications and pipes. Contact tech support for application use
Corrosion resistant	Stainless steel metal parts on all Size C, D and E and all high temperature sensors
Aluminum	Aluminum metal parts on all HP and Universal size A and B (Corrosion resistant on request for size B)
Spare	Not available as part of a configured product, must be ordered separately
CE	Transmitter and sensors certified for sale in the EU
Trackless mount	Sensors fixed only by straps, no other mounting (spacer bar as an option) - not recommended
Tracks	Permanent installation for universal size A/B, high precision size A/B and all sizes of high temperature. Tracks always come as dual-part for either direct or reflect mounting, and always with straps.
Frames	Three sizes, for permanent installation for universal size C/ D/ E, and for high precision size C/D. For universal and high precision size B available for pipes > 125 OD (Spare)
T1	Usable from -40 ... +120 °C (-40 ... +248 °F), but best for Ø temperature below 80 °C (< 176 °F), standard
T2	Usable from -40 ... +120 °C (-40 ... +248 °F), but best for Ø temperature above 80 °C (> 176 °F)
Submersible	Sensors can be used submerged; adding Denso for supplemental protection is recommended

Flow Measurement

SITRANS F S Clamp-on

Ultrasonic flow sensor SITRANS FSS200

Sensor availability guide

Sensor models	Availability											
	Standard	Spare only	ATEX/FM/IECEX	Corrosion resistant	Trackless	Tracks	Frames	High precision mount	T1 best use < 80 °C (176 °F)	T2 best use > 80 °C (176 °F)	Submersible	Catalog
FSS200 Universal Sensor -40 ... 120 °C (-40 ... +248 °F) Polyetherimide - stainless steel housing CE IP68												
A1 Universal for pipe OD – 5.8 ... 50.8 mm (0.23" ... 2")		X	X	X	X ¹⁾	X					X	
A2 Universal for pipe OD – 12.7 ... 50.8 mm (0.5" ... 2")	X		X	X	X ¹⁾	X					X	X
B1 Universal for pipe OD – 12.7 ... 76 mm (0.5" ... 3")		X	X	X	X ¹⁾	X	X				X	
B2 Universal for pipe OD – 12.7 ... 76 mm (0.5" ... 3")		X	X	X	X ¹⁾	X	X				X	
B3 Universal for pipe OD – 19 ... 127 mm (0.75" ... 5")	X		X	X	X ¹⁾	X	X				X	X
C1 Universal for pipe OD – 51 ... 254 mm (2" ... 10")		X	X	X	X		X				X	
C2 Universal for pipe OD – 51 ... 254 mm (2" ... 10")		X	X	X	X		X				X	
C3 Universal for pipe OD – 51 ... 305 mm (2" ... 12")	X		X	X	X		X				X	X
D1 Universal for pipe OD – 102 ... 508 mm (4" ... 20")		X	X	X	X		X				X	
D2 Universal for pipe OD – 152 ... 610 mm (6" ... 24")		X	X	X	X		X				X	
D3 Universal for pipe OD – 203 ... 610 mm (8" ... 24")	X		X	X	X		X				X	X
*E1 Universal for pipe OD – 254 ... 3048 mm (10" ... 120")		X	X	X	X		X				X	
*E2 Universal for pipe OD – 254 ... 6096 mm (10" ... 240")	X		X	X	X		X				X	X
*E3 Universal for pipe OD – 304 ... 10007 mm (12" ... 394")		X	X	X	X		X	X			X	
FSS200 High Precision Sensor -40 ... +120 °C (-40 ... +248 °F) Polyetherimide - stainless steel housing T1/T2 CE IP68												
A1H (High Precision) for pipe WT - 0.64 ... 1.0 mm (0.025" ... 0.04")		X	X	X	X ¹⁾	X			X		X	X
A2H (High Precision) for pipe WT - 1.0 ... 1.5 mm (0.04" ... 0.06")	X		X	X	X ¹⁾	X			X		X	X
A3H (High Precision) for pipe WT - 1.5 ... 2.0 mm (0.06" ... 0.08")	X		X	X	X ¹⁾	X			X		X	X
B1H (High Precision) for pipe WT - 2.0 ... 3.0 mm (0.08" ... 0.12")	X		X	X	X ¹⁾	X	X		X	X	X	X
B2H (High Precision) for pipe WT - 3.0 ... 4.1 mm (0.12" ... 0.16")	X		X	X	X ¹⁾	X	X		X	X	X	X
B3H (High Precision) for pipe WT - 2.7 ... 3.3 mm (0.106" ... 0.128")		X	X	X	X ¹⁾	X	X		X	X	X	X
C1H (High Precision) for pipe WT - 4.1 ... 5.8 mm (0.16" ... 0.23")	X		X	X	X		X	X	X	X	X	X
C2H (High Precision) for pipe WT - 5.8 ... 8.1 mm (0.23" ... 0.32")	X		X	X	X		X	X	X	X	X	X
* D1H (High Precision) for pipe WT - 8.1 ... 11.2 mm (0.32" ... 0.44")	X		X	X	X		X	X	X	X	X	X
* D2H (High Precision) for pipe WT - 11.2 ... 15.7 mm (0.44" ... 0.62")	X		X	X	X		X	X	X	X	X	X
* D3H (High Precision) for pipe WT - 7.4 ... 9.0 mm (0.293" ... 0.354")		X	X	X	X		X	X	X	X	X	X
* D4H (High Precision) for pipe WT - 15.7 ... 31.8 mm (0.62" ... 1.25")	X		X	X	X		X	X	X	X	X	X
FSS200 High Temperature Universal Sensor -40 ... +230 °C (-40 ... +446 °F)												
High Temperature size 1 ... 230 °C (Ø 12.7 ... 100 mm)		X	X	X		X						
High Temperature size 2 ... 230 °C (Ø 30 ... 200 mm)	X		X	X		X						X
High Temperature size 3 ... 230 °C (Ø 150 ... 610 mm)	X		X	X		X						X
High Temperature size 4 ... 230 °C (Ø 400 ... 1200 mm)	X		X	X		X						X
High Temperature size 2A ... 230 °C (Ø 30 ... 200 mm)		X	X	X		X						
High Temperature size 3A ... 230 °C (Ø 150 ... 610 mm)		X	X	X		X						
High Temperature size 4A ... 230 °C (Ø 400 ... 1200 mm)		X	X	X		X						

¹⁾ Usable, but not recommended for selection.

Sensor mounting availability guide

	Sensor		
	FSS200 Dedicated Universal	FSS200 Dedicated High precision	FSS200 High temperature Universal
Mounting			
Trackless ¹⁾	X	X	
Tracks universal dedicated	X		
Tracks HP dedicated		X	
Frames universal dedicated	X		
Frames HP dedicated		X	
Tracks high temperature universal			X
High precision mounting single enclosure		X	
High precision mounting dual enclosure		X	
SpacerBar	X	X	
Straps	X	X	X
Chains EZ-Clamp 1	Size C, D	Size C	
Chains EZ-Clamp 2	Size E	Size D	
Denso	X	X	

¹⁾ Usable but not recommended

Flow Measurement

SITRANS F S Clamp-on

Transmitter SITRANS FST030, wall mount housing

Overview



FST030 is based on the latest developments within Digital Signal Processing (DSP) technology – engineered for high measuring performance, fast response to step changes in flow, high immunity against process noise, easy to install commission and maintain.

The FST030 transmitter delivers true multi-parameter measurements i.e. volume flow, standard volume flow, density, mass flow, fluid sound velocity and temperature.

The multiple outputs and bus communication mean that all primary process information can be read either instantaneously (10 ms update) or periodically as required by plant operations.

Process values

- Volume flow
- Mass flow
- Flow velocity
- Sound velocity
- Standard volume flow (hydrocarbon variant only)
- Density
- Kinematic viscosity
- Pressure
- Medium temperature
- Specific gravity (hydrocarbon variant only)
- Totalizer 1
- Totalizer 2
- Totalizer 3
- Standard density (hydrocarbon variant only)
- Standard specific gravity (hydrocarbon variant only)
- Standardizing factor (hydrocarbon variant only)
- Liquident (hydrocarbon variant only)
- API gravity (hydrocarbon variant only)
- Standard API gravity (hydrocarbon variant only)
- Standard kinematic viscosity (hydrocarbon variant only)
- Liquid identifier (hydrocarbon variant only)

Benefits

Flow calculation and measurement

- Dedicated volume flow calculation with DSP technology
- 100 Hz update rate for all output on all primary process values
- Maximum data age from sensor to output is 20 ms
- Independent low flow cut-off settings for volume and mass flow, standard volume flow and velocity
- Zero-point adjustment on command from discrete input or host system

Operation and display

- User-configurable operation display
 - Full graphical display 240 x 160 pixels with up to 6 programmable views
 - Self-explaining alarm handling/log in clear text
 - Help text for all parameters appears automatically in the configuration menu
- SensorFlash technology stores production specific system documentation and provides removable memory of all flowmeter setups and functions
 - Calibration certificates (with ordered calibration)
 - Non-volatile memory backup of operational data
 - Transfer of user configuration to other flowmeters
 - 4GB SD card for storage and data logging
 - Audit trail of all parameter changes
 - Alarm logging

Alarms and safety

- Advanced diagnosis and service menu enhances troubleshooting and meter validation
- Configurable upper and lower alarm and warning limits for all process values
- Alarm handling can be selected between Siemens and NAMUR standard configurations

Outputs and control

- Monitoring comprising of 3 individually configurable totalizers
- Multi-parameter outputs, configurable outputs assigned individually to any of the following parameters:
 - Volume flow
 - Standard volume flow
 - Mass flow
 - Flow velocity
 - Sound velocity
 - Density
 - Process viscosity
 - Process pressure
 - Process/medium temperature

Up to six I/O channels are configured as follows.

Channel 1

Channel 1 is 4 to 20 mA analog output with HART 7.5. The current signal can be configured for massflow, volumeflow and includes the availability of active or passive function selected by wiring on the non-Ex terminals. Alternative Modbus RTU RS 485 is available.

Channel 2

Channel 2 is a signal output which can be freely configured for any process variable.

- Analog current (0/4 to 20 mA)
- Frequency or pulse
- Operational and alarm status

Channels 3 and 4

Channels 3 and 4 can be ordered with signal (freely configured for any process variable) or relay outputs, or signal input.

Signal output

Signal output can be user configured to:

- Analog current (0/4 to 20 mA)
- Frequency or pulse
- Redundant frequency or pulse (linked to channel 2)
- Operational and alarm status

Signal input

Signal input can be user-configured for:

- Totalizer reset functions
- Force outputs or freeze process values
- Initiate automatic zero point adjustment

Relay

Relay output(s) can be user configured to:

- Alarm status

4-20 mA signal outputs and inputs are ordered as active or passive for Ex versions, active and passive for non-Ex versions - function selected by wiring on the terminals.

During initial commissioning of the flowmeter, all outputs can be forced to a preset value for simulation, verification or calibration purposes.

Channels 5 and 6

- RTD temperature inputs for 1000, 500 or 100 Ω RTD's - 2, 3 or 4 wire RTD's supported

Approvals and certificates

The SITRANS FST030 transmitter was designed to comply with or exceed the requirements of international standards and regulations.

Design

The SITRANS FST030 is designed in an IP67/NEMA 4X aluminum enclosure with corrosion resistant coating. It can be wall or pipe mounted and the enclosure can be locked with a padlock or wired with lead security seals. Includes all flow and DSL functions integrated into one unit.

The FST030 is available as standard with one current, HART 7.5 output and can be ordered with additional input/output functions.

The transmitter has a modular design with discrete, replaceable electronic modules and connection boards to maintain separation between functions and facilitate field service. All modules are fully traceable and their provenance is included in the transmitter setup.

SensorFlash

SensorFlash is a standard, 4 GB micro SD card with the ability to be updated by PC. It is supplied with each transmitter and comes with a complete set of certification documents including report if ordered. Factory conformance certificates are optional at ordering.

The Siemens SensorFlash memory unit offers the following features and benefits:

- Copy site setups to SD card for easy transfer to other similar transmitters
- Permanent database of operational and functional information from the moment that the flowmeter is switched on
- New firmware updates can be downloaded from the Siemens internet portal for Product Support and placed onto SensorFlash (unmounted from the transmitter and inserted into a PC's SD card slot). The firmware is then inserted into the existing flowmeter for system/firmware upgrade.

Function

The following functions are available:

- Up to four configurable outputs and 2 RTD input channels selected at ordering
- Outputs can be individually configured for mass flow, volume flow etc.
- Three built-in totalizers which can count positive, negative or net flows
- Independent low flow cut-offs, adjustable
- Uni/bidirectional flow measurement
- Flow direction adjustable
- Alarm system consisting of alarm-log, alarm pending menu
- Change log, logs all changes made to menu parameters or via communications
- Internal data logger
- Display of operating time with real-time clock
- Flowrate outputs are freely configurable between maximum negative and maximum positive flows according to the sensor capacity
- Limit switches programmable for flow, density and temperature. Limit points can be graded as warning and alarm for values both above and below nominal process conditions
- Zero adjustment menu, with zero point evaluation display
- Full service menu for effective and straight forward application and meter troubleshooting
- Precise temperature measurement ensures optimal accuracy on massflow and density
- Fully compatible with Siemens PDM version 8.2 service pack 1 or higher

Flow Measurement

SITRANS F S Clamp-on

Transmitter SITRANS FST030, wall mount housing

Technical specifications

Process media	<ul style="list-style-type: none"> • Suitable for virtually any sonically conductive fluid, including hazardous liquids • Aggregate state: Light slurry and liquid
Process variables	<ul style="list-style-type: none"> • Volume flow • Mass flow • Flow velocity • Sound velocity • Standard volume flow (hydrocarbon variant only) • Density • Kinematic viscosity • Pressure • Medium temperature • Specific gravity (hydrocarbon variant only) • Totalizer 1 • Totalizer 2 • Totalizer 3 • Standard density (hydrocarbon variant only) • Standard specific gravity (hydrocarbon variant only) • Standardizing factor (hydrocarbon variant only) • Liquident (hydrocarbon variant only) • API gravity (hydrocarbon variant only) • Standard API gravity (hydrocarbon variant only) • Standard kinematic viscosity (hydrocarbon variant only) • Liquid identifier (hydrocarbon variant only)
Current output	
Current	0 ... 20 mA or 4 ... 20 mA (channel 1 only 4 ... 20 mA)
Load	< 500 Ω per channel
Time constant	0 ... 100 s adjustable
Digital output¹⁾	
Pulse	41.6 μs ... 5 s pulse duration
Frequency	0 ... 10 kHz, 50 % duty cycle, 120 % overscale provision
Time constant	0 ... 100 s adjustable
Active	0 ... 22 V DC, 30 mA, short-circuit-protected
Passive	3 ... 30 V DC, max. 110 mA
Relay	
Type	SPDT dry contact relay
Load	30 V AC/100 mA
Functions	Alarm level, alarm number, limit, flow direction
Digital input	
Voltage	15 ... 30 V DC (2 ... 15 mA)
Current	4 ... 20 mA
Functionality	Reset totalizer 1, 2 and 3, force output, freeze process values, zero point adjustment

Galvanic isolation	All inputs and outputs are galvanically isolated, isolation voltage 500 V
Alarm and warning limit	Available for all process values
Totalizer	Three counters for forward, net and reverse flow
Display	<ul style="list-style-type: none"> • Background illumination with alpha-numerical text to indicate flow rate, totalized values, settings and faults • Adjustable damping constant of 0 ... 100 s • Reverse flow indicated by negative sign
SD card functions	<ul style="list-style-type: none"> • Parameter change log • Configurable data logger • FW update log • Diagnostic log • Error and alarm log • Parameter backup
Ambient temperature	
Operation	
• Transmitter	-40 ... +60 °C (-40 ... +140 °F), (humidity max. 95 %)
• Display	-20 ... +60 °C (-4 ... +140 °F)
Storage	
• Transmitter	-40 ... +70 °C (-40 ... +158 °F) (humidity max. 95 %)
Communication	HART 7.5 Modbus RTU RS 485
Enclosure	
Material	Aluminum
Rating	IP66/67, NEMA 4X to IEC 529 and DIN 40050 (1 mH ₂ O for 30 min.)
Mechanical load	18 ... 400 Hz random, 3.17 g RMS, in all directions
Power supply	
Universal	20 ... 27 V DC 100 ... 240 V AC, 47 ... 63 Hz
Fluctuation	No limit
Power consumption	20 W/22 VA
NAMUR	NAMUR requirements fulfilled when using Triax cable. Within the value limits according to "General requirements" with error criteria A in accordance with NE 21. Icons according to NE 107 status.
Environment	
Environmental conditions acc. to IEC/EN/UL 61010-1	<ul style="list-style-type: none"> • Altitude up to 2000 m • Pollution degree 2 • Overvoltage category II
Maintenance	The flowmeter has a built-in error log/pending menu which should be inspected on a regular basis
Cable glands	Cable glands are available in nylon, nickel plated brass or stainless steel (316L/W1.4404)

Transmitter SITRANS FST030, wall mount housing

Approvals

For non-hazardous area	No approval required
For hazardous area (transmitter pending)	
• ATEX	
- Sensor	Zone 0, 1, 2
- Transmitter with integrated DSL	Zone 2
• FM	
- Sensor	Class 1, Div 1, 2
- Transmitter	Class 1, Div 2
• FM Canada	
- Sensor	Class 1, Div 1, 2 (Zone 0, 1, 2)
- Transmitter with integrated DSL	Class 1, Div 2 (Zone 2)
• Combination Approval: ATEX, IECEx, FM, FM Canada	
- Sensor	Zone 0, 1, 2 (Div 1,2)
- Transmitter with integrated DSL	Zone 2 (Div 2)

Certificates

CE conformity marking	<ul style="list-style-type: none"> • Low voltage directive • WEEE • RoHS
-----------------------	---

EMC performance

Emission	CISPR 11:2009/A1:2010 and EN 55011:2009/A1:2010
Immunity	IEC/EN 61326-1:2013

Dimensional drawing

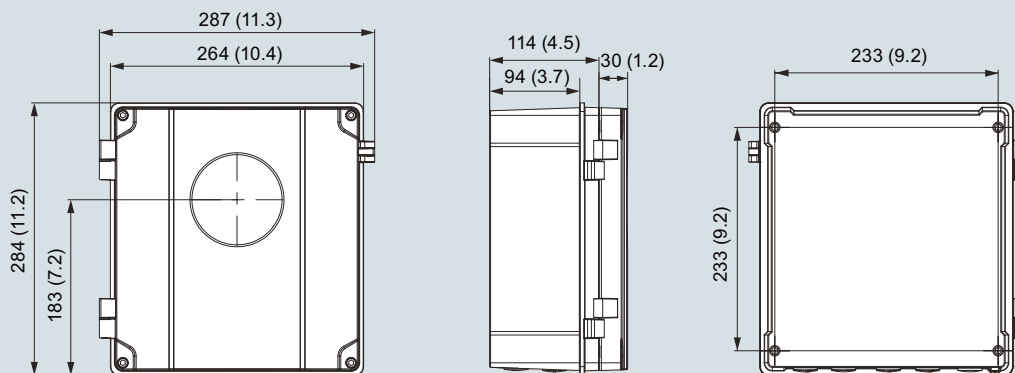

SITRANS FST030, wall mount version, dimensions in mm (inch)

Flow Measurement

SITRANS F S Clamp-on

Ultrasonic flowmeter SITRANS FS230 - Ordering data

Selection and Ordering data	Article No.	Ord. code
SITRANS FS230 clamp-on flowmeter	7ME372	
Click on the Article No. for the online configuration in the PIA Life Cycle Portal.		
Transmitter model		
No transmitter, external DSL only	0	
Transmitter FST030	3	
Pipe material/temperature		
Transmitter only - no sensor	0	
Steel (stainless steel, carbon steel), temperature range: best use < 80 °C (176 °F)	1	
Steel (stainless steel, carbon steel), temperature range: best use > 80 °C (176 °F)	2	
Plastic (PVC) (for liquid applications), temperature: -40 ... +121 °C (-40 ... 250 °F)	6	
Any material, temperature: -40 ... +121 °C (-40 ... 250 °F)	7	
Any material, very high temperature: -40 ... +230 °C (-40 ... 446 °F)	8	
Pipe outer diameter range		
Transmitter only - no sensor	A	
13 ... 19 mm (0.5 ... 0.75")	B	
19.3 ... 30.5 mm (0.76 ... 1.20")	C	
30.7 ... 50.8 mm (1.21 ... 2.00")	D	
51 ... 76 mm (2.01 ... 3.00")	E	
78 ... 127 mm (3.1 ... 5.0")	F	
129 ... 203 mm (5.1 ... 8.0")	G	
206 ... 305 mm (8.1 ... 12.0")	H	
307 ... 508 mm (12.1 ... 20.0")	J	
510 ... 813 mm (20.1 ... 32.0")	K	
815 ... 9144 mm (32.1 ... 360")	L	
Pipe wall thickness range		
Transmitter only - no sensor	A	
0.635 ... 1.016 mm (0.025 ... 0.04")	B	
1.016 ... 1.524 mm (0.04 ... 0.06")	C	
1.524 ... 2.032 mm (0.06 ... 0.08")	D	
2.032 ... 3.048 mm (0.08 ... 0.12")	E	
3.048 ... 4.064 mm (0.12 ... 0.16")	F	
4.064 ... 5.842 mm (0.16 ... 0.23")	G	
5.842 ... 8.128 mm (0.23 ... 0.32")	H	
8.128 ... 11.176 mm (0.32 ... 0.44")	J	
11.176 ... 15.748 mm (0.44 ... 0.62")	K	
15.748 ... 31.75 mm (0.62 ... 1.25")	L	
31.75 ... 50.8 mm (1.25 ... 2.00")	M	
Sensor mounting		
Transmitter only - no sensor	0	
Mounting straps only	1	
Standard frames and tracks	2	
Magnetic - no straps	4	
Magnetic - with straps	6	
High precision mount (single enclosure)	7	
High precision mount (dual enclosure)	8	
Number of paths (sensor pairs)		
Transmitter only - no sensor	0	
One path	1	
Two path	2	
Environment		
Standard	1	

Ultrasonic flowmeter SITRANS FS230 - Ordering data

Selection and Ordering data	Article No.	Ord. code
SITRANS FS230 clamp-on flowmeter	7ME372 - - - - -	
Transmitter/DSL material and mounting style Wallmount transmitter, internal DSL, transmitter: aluminum wallbox, NEMA 4X, DSL: none, direct connected sensor cables, (max 2-path, max. 20 meter sensor cable)		U
Ex approvals Non-Ex ATEX, wallbox enclosure (pending) FM, wallbox enclosure (pending) FMc, wallbox enclosure (pending) ATEX, IECEx, FM, FMc, wallbox (pending)		A B G L P
Local User Interface Blind version transmitter Graphical local user interface, 240 x 160 pixels		1 3

3

Flow Measurement

SITRANS F S Clamp-on

Ultrasonic flowmeter SITRANS FS230 - Ordering data

Selection and Ordering data	Order code	Selection and Ordering data	Order code
Further designs		Ex Passive	
Please add "-Z" to Article No. and specify Order code(s).		• Ch2: current/freq./pulse, Ch3: none, Ch4: none	F21
Cable glands - transmitter, DSL (not for sensor cables)		• Ch2: current/freq./pulse, Ch3: current/freq./pulse Ch4: None	F22
No glands, metric threads on transmitter	A01	• Ch2:current/freq./pulse, Ch3: current/freq./pulse Ch4:current/freq./pulse	F23
No glands, metric thread with NPT thread adapters, stainless steel: quantity based on selection "U" in data place 14	A60	• Ch2: current/freq./pulse, Ch3: current/freq./pulse Ch4: relay	F24
No glands, metric thread with NPT thread adapters, nickel plated brass: quantity based on selection "U" in data place 14	A61	• Ch2: current/freq./pulse, Ch3: relay, Ch4: relay	F25
Nickel plated brass glands: quantity based on selection "U" in data place 14	A62	• Ch2: current/freq./pulse, Ch3: relay, Ch4: none	F26
Plastic glands: quantity based on selection "U" in data place 14	A64	Temperature sensors and pockets	
Stainless steel glands: quantity based on selection "U" in data place 14	A66	1000 Ω platinum standard clamp-on RTD	J61
Software functions and CT approvals		1000 Ω platinum submersible clamp-on RTD	J62
Software: for standard industry applications	B11	Sensor to transmitter cables	
Software including hydrocarbon process values	B39	10 m (32.8 ft) standard/submersible coax sensor cable pair with nylon glands	K24
I/O configuration Ch1		20 m (65.6 ft) standard/submersible coax sensor cable pair with nylon glands	K25
Non-Ex, 4 ... 20 mA HART, menu selected pas- sive/active	E02	10 m (32.8 ft) standard/submersible coax sensor cable pair with nickel plated brass glands	K29
Ex, 4 ... 20 mA HART, active	E06	20 m (65.6 ft) standard/submersible coax sensor cable pair with nickel plated brass glands	K30
Ex, 4 ... 20 mA HART, passive	E07	10 m (32.8 ft) standard/submersible coax sensor cable pair with stainless steel glands	K34
Modbus RTU 485	E14	20 m (65.6 ft) standard/submersible coax sensor cable pair with stainless steel glands	K35
I/O configuration Ch2, Ch3 and Ch4		20 m (65.6 ft) plenum rated coax sensor cable pair with nylon glands	K37
None	F00	20 m (65.6 ft) plenum rated coax sensor cable pair with nickel plated brass glands	K39
Non-Ex		20 m (65.6 ft) plenum rated coax sensor cable pair with stainless steel glands	K41
• Ch2: current/freq./pulse, Ch3: none Ch4: none. Active/passive menu selected	F01	10 m (32.8 ft) armored sensor cable pair with nickel plated brass glands	K53
• Ch2: current/freq./pulse, Ch3: current/freq./pulse Ch4: none. Active/passive menu selected	F02	20 m (65.6 ft) armored sensor cable pair with nickel plated brass glands	K54
• Ch2:current/freq./pulse, Ch3: current/freq./pulse Ch4:current/freq./pulse. Active/passive menu selected	F03		
• Ch2:current/freq./pulse, Ch3: current/freq./pulse Ch4: relay. Active/passive menu selected	F04		
• Ch2: current/freq./pulse, Ch3: relay Ch4: relay. Ac- tive/passive menu selected	F05		
• Ch2: current/freq./pulse, Ch3: relay Ch4: none. Ac- tive/passive menu selected	F06		
Ex Active			
• Ch2: current/freq./pulse, Ch3: none Ch4: none	F11		
• Ch2: current/freq./pulse, Ch3: current/freq./pulse Ch4: none	F12		
• Ch2: current/freq./pulse, Ch3: current/freq./pulse Ch4: current/freq./pulse	F13		
• Ch2: current/freq./pulse, Ch3: current/freq./pulse, Ch4: relay	F14		
• Ch2: current/freq./pulse, Ch3: relay, Ch4: relay	F15		
• Ch2: current/freq./pulse, Ch3: relay, Ch4: none	F16		

Selection and Ordering data	Order code
RTD cable (clamp temperature sensor to transmitter)	
6 m (20 ft) standard RTD cable	R50
15 m (50 ft) standard RTD cable	R51
30 m (100 ft) standard RTD cable	R52
46 m (150 ft) standard RTD cable	R53
61 m (200 ft) standard RTD cable	R54
91 m (300 ft) standard RTD cable	R55
6 m (20 ft) submersible RTD cable	R56
15 m (50 ft) submersible RTD cable	R57
30 m (100 ft) submersible RTD cable	R58
46 m (150 ft) submersible RTD cable	R59
61 m (200 ft) submersible RTD cable	R60
91 m (300 ft) submersible RTD cable	R61
RTD cable (insert temperature sensor to transmitter)	
15 m (50 ft) RTD cable with nickel plated gland	R74
15 m (50 ft) RTD cable with stainless steel gland	R75
30 m (100 ft) RTD cable with nickel plated gland	R76
30 m (100 ft) RTD cable with stainless steel gland	R77
91 m (300 ft) RTD cable with nickel plated gland	R78
91 m (300 ft) RTD cable with stainless steel gland	R79
15 m (50 ft) insert RTD cable with nickel plated gland	R80
15 m (50 ft) insert RTD cable with stainless steel gland	R81
30 m (100 ft) insert RTD cable with nickel plated gland	R82
30 m (100 ft) insert RTD cable with stainless steel gland	R83
91 m (300 ft) insert RTD cable with nickel plated gland	R84
91 m (300 ft) insert RTD cable with stainless steel gland	R85
Tag plate	
Tag plate for transmitter, stainless steel	Y15
Tag name plate, stainless steel	Y17

Flow Measurement

SITRANS F S Clamp-on

Ultrasonic flowmeter SITRANS FS230 - Accessories/Spare parts

Selection and Ordering data	Article No.
System spare parts	
Tool kits and loose parts "F" connector tool kit, 2 per Bag of loose spare parts; for wallmount, including cable strain relief components, mounting tool, seals and gasket, assorted screws and washers, hex cap nut, blind plugs, and O-rings	A5E38145699 A5E38288072
Electronics assemblies and modules	
Wall box <ul style="list-style-type: none"> • Display and keypad assembly • Digital Sensor Link (DSL), internal, for wall box • SensorFlash (4 GB micro SD card) -40 °C ... +85 °C • Power supply, for wall box, (240 V AC, 47 ... 63 Hz), (24 ... 90 V DC) • Foam insert for wall box with connectors 	A5E37697615 A5E38014726 A5E38288507 A5E38263021 A5E38287828
Cassettes, I/O configuration and communication	
Ex <ul style="list-style-type: none"> • Ch1: I/O and comm (active) 4 ... 20 mA output and HART 7.2 • Ch1: I/O and comm (passive) 4 ... 20 mA output and HART 7.2 • Ch1: communication Modbus RTU 485 	A5E38012278 A5E38013025 A5E38013054
Non Ex <ul style="list-style-type: none"> • Ch1: I/O and comm (active/passive) 4 ... 20 mA output and HART 7.2 • Ch1: communication Modbus RTU 485 • Ch2: current/freq./pulse, Ch3: None Ch4: none. Menu select active/passive • Ch2: current/freq./pulse, Ch3: current/freq./pulse Ch4: none. Menu select active/passive • Ch2: current/freq./pulse, Ch3: current/freq./pulse Ch4: current/Freq./Pulse. Menu select active/passive • Ch2: current/freq./pulse, Ch3: current/freq./pulse Ch4: relay. Menu select active/passive • Ch2: current/freq./pulse, Ch3: relay Ch4: relay. Menu select active/passive • Ch2: current/freq./pulse, Ch3: relay Ch4: none. Menu select active/passive 	A5E38013040 A5E38013069 A5E38006256 A5E38006558 A5E38006598 A5E38006896 A5E38006900 A5E38011432
Ex Passive <ul style="list-style-type: none"> • Ch2: current/freq./pulse, Ch3: None Ch4: none • Ch2: current/freq./pulse, Ch3: current/freq./pulse Ch4: none • Ch2: current/freq./pulse, Ch3: current/freq./pulse Ch4: current/freq./pulse • Ch2: current/freq./pulse, Ch3: current/freq./pulse Ch4: relay • Ch2: current/freq./pulse, Ch3: relay Ch4: relay • Ch2: current/freq./pulse, Ch3: relay Ch4: none 	A5E38012039 A5E38012056 A5E38012121 A5E38019235 A5E38019263 A5E38019378
Ex Active <ul style="list-style-type: none"> • Ch2: current/freq./pulse, Ch3: none Ch4: none • Ch2: current/freq./pulse, Ch3: current/freq./pulse Ch4: none • Ch2: current/freq./pulse, Ch3: current/freq./pulse Ch4: current/freq./pulse • Ch2: current/freq./pulse, Ch3: current/freq./pulse Ch4: relay • Ch2: current/freq./pulse, Ch3: relay Ch4: relay • Ch2: current/freq./pulse, Ch3: relay Ch4: none 	A5E38011478 A5E38011509 A5E38011541 A5E38011600 A5E38011618 A5E38011908
Miscellaneous parts	
Wall bracket "pipe mounting" Wall bracket "panel mounting" Metal kit: PSU cover, back plane Power input cover plate Blind plug brass-nickel 10 pcs (Ex version) Blind plug stainless steel 10 pcs (Ex version) F connectors, 4 pcs	A5E38288020 A5E38288032 A5E38415145 A5E38415205 A5E38145685 A5E38145689 A5E38268608

Article No./Sensor Crossreference

Steel (T1)			Steel (T2)			Plastic (liquid)		
Data place 8,9,10 of 7ME372-... combination	Sensor part number	Sensor Size Code	Data place 8,9,10 of 7ME372-... combination	Sensor part number	Sensor Size Code	Data place 8,9,10 of 7ME372-... combination	Sensor part number	Sensor Size Code
1BB	7ME3950-5LG01	A1HT1	2BB	7ME3950-5LB11	A1	6BB	7ME3950-5LB01	A2
1BC	7ME3950-5LH01	A2HT1	2BC	7ME3950-5LB01	A2	6BC	7ME3950-5LB01	A2
1BD	7ME3950-5LB11	A1	2BD	7ME3950-5LB11	A1	6BD	7ME3950-5LB01	A2
1BE	7ME3950-5LB01	A2	2BE	7ME3950-5LB01	A2	6BE	7ME3950-5LB01	A2
1BF	7ME3950-5LB11	A1	2BF	7ME3950-5LB11	A1	6BF	7ME3950-5LB01	A2
1CB	7ME3950-5LG01	A1HT1	2CB	7ME3950-5LB11	A1	6CB	7ME3950-5LB01	A2
1CC	7ME3950-5LH01	A2HT1	2CC	7ME3950-5LB01	A2	6CC	7ME3950-5LB01	A2
1CD	7ME3950-5LJ01	A3HT1	2CD	7ME3950-5LB11	A1	6CD	7ME3950-5LB01	A2
1CE	7ME3950-5GK01	B1HT1	2CE	7ME3950-5GK21	B1HT2	6CE	7ME3950-5LB01	A2
1CF	7ME3950-5LB11	A1	2CF	7ME3950-5LB11	A1	6CF	7ME3950-5LB01	A2
1CG	7ME3950-5LB11	A1	2CG	7ME3950-5LB11	A1	6CG	7ME3950-5LB01	A2
1DB	7ME3950-5LG01	A1HT1	2DB	7ME3950-5LC11	B1	6DC	7ME3950-5LC01	B3
1DC	7ME3950-5LH01	A2HT1	2DC	7ME3950-5LC21	B2	6DD	7ME3950-5LC01	B3
1DD	7ME3950-5LJ01	A3HT1	2DD	7ME3950-5LC11	B1	6DE	7ME3950-5LC01	B3
1DE	7ME3950-5GK01	B1HT1	2DE	7ME3950-5GK21	B1HT2	6DF	7ME3950-5LC01	B3
1DF	7ME3950-5GL01	B2HT1	2DF	7ME3950-5GL21	B2HT2	6DG	7ME3950-5LC01	B3
1DG	7ME3950-5LC01	B3	2DG	7ME3950-5LC01	B3	6DH	7ME3950-5LC01	B3
1DH	7ME3950-5LC21	B2	2DH	7ME3950-5LC21	B2	6EC	7ME3950-5LC01	B3
1EB	7ME3950-5LG01	A1HT1	2EB	7ME3950-5LC11	B1	6ED	7ME3950-5LC01	B3
1EC	7ME3950-5LH01	A2HT1	2EC	7ME3950-5LC21	B2	6EE	7ME3950-5LC01	B3
1ED	7ME3950-5LJ01	A3HT1	2ED	7ME3950-5LC11	B1	6EF	7ME3950-5LC01	B3
1EE	7ME3950-5GK01	B1HT1	2EE	7ME3950-5GK21	B1HT2	6EG	7ME3950-5LC01	B3
1EF	7ME3950-5GL01	B2HT1	2EF	7ME3950-5GL21	B2HT2	6EH	7ME3950-5LC01	B3
1EG	7ME3950-5GM00	C1HT1	2EG	7ME3950-5GM20	C1HT2	6EJ	7ME3950-5LC01	B3
1EH	7ME3950-5GN00	C2HT1	2EH	7ME3950-5GN20	C2HT2	6EK	7ME3950-5LC01	B3
1EJ	7ME3950-5LC01	B3	2EJ	7ME3950-5LC01	B3	6FE	7ME3950-5LD00	C3
1EK	7ME3950-5LC01	B3	2EK	7ME3950-5LC01	B3	6FF	7ME3950-5LD00	C3
1FC	7ME3950-5LH01	A2HT1	2FC	7ME3950-5LD10	C1	6FG	7ME3950-5LD00	C3
1FD	7ME3950-5LJ01	A3HT1	2FD	7ME3950-5LD10	C1	6FH	7ME3950-5LD00	C3
1FE	7ME3950-5GK01	B1HT1	2FE	7ME3950-5GK21	B1HT2	6FJ	7ME3950-5LD00	C3
1FF	7ME3950-5GL01	B2HT1	2FF	7ME3950-5GL21	B2HT2	6FK	7ME3950-5LD00	C3
1FG	7ME3950-5GM00	C1HT1	2FG	7ME3950-5GM20	C1HT2	6GF	7ME3950-5LD00	C3
1FH	7ME3950-5GN00	C2HT1	2FH	7ME3950-5GN20	C2HT2	6GG	7ME3950-5LD00	C3
1FJ	7ME3950-5GP00	D1HT1	2FJ	7ME3950-5GP20	D1HT2	6GH	7ME3950-5LD00	C3
1FK	7ME3950-5LD10	C1	2FK	7ME3950-5LD10	C1	6GJ	7ME3950-5LD00	C3
1GD	7ME3950-5LJ01	A3HT1	2GD	7ME3950-5LD10	C1	6GK	7ME3950-5LD00	C3
1GE	7ME3950-5GK01	B1HT1	2GE	7ME3950-5GK21	B1HT2	6GL	7ME3950-5LD00	C3
1GF	7ME3950-5GL01	B2HT1	2GF	7ME3950-5GL21	B2HT2	6HG	7ME3950-5LE00	D3
1GG	7ME3950-5GM00	C1HT1	2GG	7ME3950-5GM20	C1HT2	6HH	7ME3950-5LE00	D3
1GH	7ME3950-5GN00	C2HT1	2GH	7ME3950-5GN20	C2HT2	6HJ	7ME3950-5LE00	D3
1GJ	7ME3950-5GP00	D1HT1	2GJ	7ME3950-5GP20	D1HT2	6HK	7ME3950-5LE00	D3
1GK	7ME3950-5GQ00	D2HT1	2GK	7ME3950-5GQ20	D2HT2	6HL	7ME3950-5LE00	D3
1GL	7ME3950-5LD00	C3	2GL	7ME3950-5LD00	C3	6HM	7ME3950-5LE00	D3
1HE	7ME3950-5GK01	B1HT1	2HE	7ME3950-5GK21	B1HT2	6JJ	7ME3950-5LE00	D3
1HF	7ME3950-5GL01	B2HT1	2HF	7ME3950-5GL21	B2HT2	6JK	7ME3950-5LE00	D3
1HG	7ME3950-5GM00	C1HT1	2HG	7ME3950-5GM20	C1HT2	6JL	7ME3950-5LE00	D3
1HH	7ME3950-5GN00	C2HT1	2HH	7ME3950-5GN20	C2HT2	6JM	7ME3950-5LE00	D3
1HJ	7ME3950-5GP00	D1HT1	2HJ	7ME3950-5GP20	D1HT2	6KK	7ME3950-5LF00	E2
1HK	7ME3950-5GQ00	D2HT1	2HK	7ME3950-5GQ20	D2HT2	6KL	7ME3950-5LF00	E2
1HL	7ME3950-5GR00	D4HT1	2HL	7ME3950-5GR20	D4HT2	6KM	7ME3950-5LF00	E2
1JG	7ME3950-5GM00	C1HT1	2JG	7ME3950-5GM20	C1HT2	6LM	7ME3950-5LF00	E2
1JH	7ME3950-5GN00	C2HT1	2JH	7ME3950-5GN20	C2HT2			
1JJ	7ME3950-5GP00	D1HT1	2JJ	7ME3950-5GP20	D1HT2			
1JK	7ME3950-5GQ00	D2HT1	2JK	7ME3950-5GQ20	D2HT2			
1JL	7ME3950-5GR00	D4HT1	2JL	7ME3950-5GR20	D4HT2			
1KH	7ME3950-5GN00	C2HT1	2KH	7ME3950-5GN20	C2HT2			
1KJ	7ME3950-5GP00	D1HT1	2KJ	7ME3950-5GP20	D1HT2			
1KK	7ME3950-5GQ00	D2HT1	2KK	7ME3950-5GQ20	D2HT2			
1KL	7ME3950-5GR00	D4HT1	2KL	7ME3950-5GR20	D4HT2			
1LJ	7ME3950-5GP00	D1HT1	2LJ	7ME3950-5GP20	D1HT2			
1LK	7ME3950-5GQ00	D2HT1	2LK	7ME3950-5GQ20	D2HT2			
1LL	7ME3950-5GR00	D4HT1	2LL	7ME3950-5GR20	D4HT2			



Flow Measurement

SITRANS F S Clamp-on

Ultrasonic flowmeter SITRANS FS230 - Accessories/Spare parts

Other (Univ)			Other (VH)			
Data place 8,9,10 of 7ME372-... combination	Sensor part number	Sensor Size Code	Data place 8,9,10 of 7ME372-... combination	Sensor part number	Sensor Size Code	
	7BB	7ME3950-5LB01	A2	8BB	7ME3950-5LA13	1
	7BC	7ME3950-5LB01	A2	8BC	7ME3950-5LA13	1
	7BD	7ME3950-5LB01	A2	8BD	7ME3950-5LA13	1
	7BE	7ME3950-5LB01	A2	8BE	7ME3950-5LA13	1
	7BF	7ME3950-5LB01	A2	8BF	7ME3950-5LA13	1
	7CB	7ME3950-5LB01	A2	8CB	7ME3950-5LA13	1
	7CC	7ME3950-5LB01	A2	8CC	7ME3950-5LA13	1
	7CD	7ME3950-5LB01	A2	8CD	7ME3950-5LA13	1
	7CE	7ME3950-5LB01	A2	8CE	7ME3950-5LA13	1
	7CF	7ME3950-5LB01	A2	8CF	7ME3950-5LA13	1
	7CG	7ME3950-5LB01	A2	8CG	7ME3950-5LA13	1
	7DB	7ME3950-5LC01	B3	8DB	7ME3950-5LA13	1
	7DC	7ME3950-5LC01	B3	8DC	7ME3950-5LA13	1
	7DD	7ME3950-5LC01	B3	8DD	7ME3950-5LA13	1
	7DE	7ME3950-5LC01	B3	8DE	7ME3950-5LA13	1
	7DF	7ME3950-5LC01	B3	8DF	7ME3950-5LA13	1
	7DG	7ME3950-5LC01	B3	8DG	7ME3950-5LA13	1
	7DH	7ME3950-5LC01	B3	8DH	7ME3950-5LA13	1
	7EB	7ME3950-5LC01	B3	8EB	7ME3950-5LA13	1
	7EC	7ME3950-5LC01	B3	8EC	7ME3950-5LA13	1
	7ED	7ME3950-5LC01	B3	8ED	7ME3950-5LA13	1
	7EE	7ME3950-5LC01	B3	8EE	7ME3950-5LA13	1
	7EF	7ME3950-5LC01	B3	8EF	7ME3950-5LA13	1
	7EG	7ME3950-5LC01	B3	8EG	7ME3950-5LA13	1
	7EH	7ME3950-5LC01	B3	8EH	7ME3950-5LA13	1
	7EJ	7ME3950-5LC01	B3	8EJ	7ME3950-5LA13	1
	7EK	7ME3950-5LC01	B3	8EK	7ME3950-5LA13	1
	7FC	7ME3950-5LD00	C3	8FC	7ME3950-5LA23	2
	7FD	7ME3950-5LD00	C3	8FD	7ME3950-5LA23	2
	7FE	7ME3950-5LD00	C3	8FE	7ME3950-5LA23	2
	7FF	7ME3950-5LD00	C3	8FF	7ME3950-5LA23	2
	7FG	7ME3950-5LD00	C3	8FG	7ME3950-5LA23	2
	7FH	7ME3950-5LD00	C3	8FH	7ME3950-5LA23	2
	7FJ	7ME3950-5LD00	C3	8FJ	7ME3950-5LA23	2
	7FK	7ME3950-5LD00	C3	8FK	7ME3950-5LA23	2
	7GD	7ME3950-5LD00	C3	8GD	7ME3950-5LA23	2
	7GE	7ME3950-5LD00	C3	8GE	7ME3950-5LA23	2
	7GF	7ME3950-5LD00	C3	8GF	7ME3950-5LA23	2
	7GG	7ME3950-5LD00	C3	8GG	7ME3950-5LA23	2
	7GH	7ME3950-5LD00	C3	8GH	7ME3950-5LA23	2
	7GJ	7ME3950-5LD00	C3	8GJ	7ME3950-5LA23	2
	7GK	7ME3950-5LD00	C3	8GK	7ME3950-5LA23	2
	7GL	7ME3950-5LD00	C3	8GL	7ME3950-5LA23	2
	7HE	7ME3950-5LE00	D3	8HE	7ME3950-5LA43	3
	7HF	7ME3950-5LE00	D3	8HF	7ME3950-5LA43	3
	7HG	7ME3950-5LE00	D3	8HG	7ME3950-5LA43	3
	7HH	7ME3950-5LE00	D3	8HH	7ME3950-5LA43	3
	7HJ	7ME3950-5LE00	D3	8HJ	7ME3950-5LA43	3
	7HK	7ME3950-5LE00	D3	8HK	7ME3950-5LA43	3
	7HL	7ME3950-5LE00	D3	8HL	7ME3950-5LA43	3
	7HM	7ME3950-5LE00	D3	8HM	7ME3950-5LA43	3
	7JG	7ME3950-5LE00	D3	8JG	7ME3950-5LA43	3
	7JH	7ME3950-5LE00	D3	8JH	7ME3950-5LA43	3
	7JJ	7ME3950-5LE00	D3	8JJ	7ME3950-5LA43	3
	7JK	7ME3950-5LE00	D3	8JK	7ME3950-5LA43	3
	7JL	7ME3950-5LE00	D3	8JL	7ME3950-5LA43	3
	7JM	7ME3950-5LE00	D3	8JM	7ME3950-5LA43	3
	7KH	7ME3950-5LF00	E2	8KH	7ME3950-5LA73	4
	7KJ	7ME3950-5LF00	E2	8KJ	7ME3950-5LA73	4
	7KK	7ME3950-5LF00	E2	8KK	7ME3950-5LA73	4
	7KL	7ME3950-5LF00	E2	8KL	7ME3950-5LA73	4
	7KM	7ME3950-5LF00	E2	8KM	7ME3950-5LA73	4
	7LJ	7ME3950-5LF00	E2	8LJ	7ME3950-5LA73	4
	7LK	7ME3950-5LF00	E2	8LK	7ME3950-5LA73	4
	7LL	7ME3950-5LF00	E2	8LL	7ME3950-5LA73	4
	7LM	7ME3950-5LF00	E2	8LM	7ME3950-5LA73	4





Ultrasonic flowmeter SITRANS FS230 - Accessories/Spare parts

Selection and Ordering data	Article No.	Selection and Ordering data	Article No.
<i>Spare parts (system)</i>		<i>Spare parts (system)</i>	
SITRANS FS230 IP65/IP66 (NEMA 4X)	7ME 3 9 5 0 - 	SITRANS FS230 IP65/IP66 (NEMA 4X)	7ME 3 9 5 0 - 
Approvals		High temperature universal liquid sensors	
All, FM/FMc, ATEX, IECEX - Flow sensors	5	Very high temperature up to 230 °C (446 °F)	
All, FM/FMc, ATEX, IECEX - Temperature sensors	1	• Size 1 (Ø 12.7 ... 100 mm (0.47 ... 3.94"))	5 LA 1 3
Spare sensor code		• Size 2 (Ø 30 ... 200 mm (1.18 ... 7.87"))	5 LA 2 3
For liquid flow sensors pipe ranges please refer to catalog sensor selection chart in the FSS200 section		• Size 2A (Ø 30 ... 200 mm (1.18 ... 7.87"))	5 LA 3 3
Flow sensors for use with mounting frames or tracks		• Size 3 (Ø 150 ... 610 mm (5.9 ... 24.0"))	5 LA 4 3
Suitable for pipes other than steel or stainless steel.		• Size 3A (Ø 150 ... 610 mm (5.9 ... 24.0"))	5 LA 6 3
Temperature -40 ... +121 °C (-40 ... +250 °F)		• Size 4 (Ø 400 ... 1200 mm (16.75 ... 47.24"))	5 LA 7 3
• A1 Universal	5 LB 1 1	• Size 4A (Ø 400 ... 1200 mm (16.75 ... 47.24"))	5 LA 8 3
• A2 Universal	5 LB 0 1	Standard RTD temperature sensors	
• B1 Universal	5 LC 1 1	Standard clamp-on RTD	1 TA 0 0
• B2 Universal	5 LC 2 1	Submersible clamp-on RTD	1 TB 0 0
• B3 Universal	5 LC 0 1	Insertion style RTD (size 1), 140 mm (5.5")	1 TJ 0 0
• C1 Universal	5 LD 1 0	Insertion style RTD (size 2), 216 mm (8.5")	1 TJ 0 1
• C2 Universal	5 LD 2 0	Insertion style RTD (size 3), 292 mm (11.5")	1 TJ 0 2
• C3 Universal	5 LD 0 0	Insertion style RTD (size 4), 368 mm (14.5")	1 TJ 0 3
• D1 Universal	5 LE 1 0		
• D2 Universal	5 LE 2 0		
• D3 Universal	5 LE 0 0		
• E1 Universal	5 LF 1 0		
• E2 Universal	5 LF 0 0		
• E3 Universal	5 LF 2 0		
Gas and liquid sensors for use with mounting frames or tracks			
Suitable for steel or stainless steel pipes			
Temperature T1			
• A1H high precision	5 LG 0 1		
• A2H high precision	5 LH 0 1		
• A3H high precision	5 LJ 0 1		
• B1H high precision	5 GK 0 1		
• B2H high precision	5 GL 0 1		
• B3H high precision	5 GT 0 1		
• C1H high precision	5 GM 0 0		
• C2H high precision	5 GN 0 0		
• D1H high precision	5 GP 0 0		
• D2H high precision	5 GQ 0 0		
• D3H high precision	5 GU 0 0		
• D4H high precision	5 GR 0 0		
Temperature T2			
• A1H high precision	5 LG 2 1		
• A2H high precision	5 LH 2 1		
• A3H high precision	5 LJ 2 1		
• B1H high precision	5 GK 2 1		
• B2H high precision	5 GL 2 1		
• B3H high precision	5 GT 2 1		
• C1H high precision	5 GM 2 0		
• C2H high precision	5 GN 2 0		
• D1H high precision	5 GP 2 0		
• D2H high precision	5 GQ 2 0		
• D3H high precision	5 GU 2 0		
• D4H high precision	5 GR 2 0		

Flow Measurement

SITRANS F S Clamp-on

Ultrasonic flowmeter SITRANS FS230 - Accessories/Spare parts

Selection and Ordering data	Article No.	Selection and Ordering data	Article No.
<i>Spare parts (Miscellaneous)</i>		<i>Spare parts (Miscellaneous)</i>	
SITRANS F S Clamp-on 	7ME3960 - 	SITRANS F S Clamp-on	7ME3960 - 
 Click on the Article No. for the online configuration in the PIA Life Cycle Portal.		Universal sensor size A or B	0MA00
		High precision sensor size A or B	0MB00
FS230 dedicated sensor mounting hardware		Stainless mounting tracks for high temperature 991 sensors	
Sensor mounting frames for		Size 1 high temperature sensor pair	CQO:992MTNHMSH-1
• Universal sensor size B (for pipes > 125 mm (5 inch))	CQO:1012FN-PB	Size 2 high temperature sensor pair	CQO:992MTNHMSH-2
• Universal sensor size C	0MC00	Size 3 high temperature sensor pair	CQO:992MTNHMSH-3
• Universal sensor size D	0MC01	Size 4 high temperature sensor pair	CQO:992MTNHMSH-4
• Universal sensor size E	0MC01		
• High precision sensor size B (For pipes > 125 mm (5 inch))	CQO:1012FNH-PB		
• High precision sensor size C	3MD00	Clamp-on RTD mounting hardware for dedicated systems	
• High precision sensor size D	3MD01	RTD mounting hardware for dedicated system	
• Magnetic mounting frames for size C, D, E, universal and high precision sensors	3MD02	• 1152 ... 610 mm (6 ... 24")	0MR00
		• 12.7 ... 50.8 mm (0.5 ... 2")	0MR01
Spacer bars (for indexing sensors on pipe)		• 31.8 ... 203.2 mm (1.25 ... 8")	0MR02
Spacer bar for pipes to 200 mm/8 inch (liquid), 600 mm/24 inch (gas)	3MS10	• 508 ... 1219 mm (20 ... 48")	0MR04
Spacer bar for pipes to 500 mm/20 inch (liquid), DN 1200/48 inch (gas)	3MS20	Junction box for clamp on RTD's	CQO:992ECJ
Spacer bar for pipes to 800 mm/32 inch (liquid)	3MS30	Insert RTD thermowells	
Spacer bar for pipes to 1200 mm/48 inch (liquid). Must be used with 7ME39600SM30	3MS40	Thermowell standard duty	
Mounting straps (slotted stainless steel)		• Uninsulated pipe 140 mm (5.5")	CQO:1012TW-1
For pipes		• Uninsulated pipe 216 mm (8.5")	CQO:1012TW-2
DN 50 ... DN 150	0SM00	• Uninsulated pipe: 292 mm (11.5")	CQO:1012TW-3
DN 50 ... DN 300	0SM10	• With lagging 140 mm (5.5")	CQO:1012TW-1L
DN 300 ... DN 600	0SM20	• With lagging 216 mm (8.5")	CQO:1012TW-2L
DN 600 ... DN 1200	0SM30	• With lagging 292 mm (11.5")	CQO:1012TW-3L
DN 1200 ... DN 1500	0SM40	Sensor cables	
DN 1500 ... DN 2100	0SM50	Coax (CE mark)	
DN 2100 ... DN 3000	0SM60	• 10 m (32.8 ft) armored sensor cable pair with nickel plated brass glands	A5E38028474004
High precision mounting enclosures for sensors		• 20 m (65.6 ft) armored sensor cable pair with nickel plated brass glands	A5E38028474005
Stainless steel mounts for high precision size "C" sensors, single enclosure	0WS50	• 10 m (32.8 ft) standard/submersible Coax sensor cable pair with Nylon glands	A5E39669934004
Stainless steel mounts for high precision size "D/E" sensors, single enclosure	0WS60	• 20 m (65.6 ft) standard/submersible Coax sensor cable pair with Nylon glands	A5E39669934005
Stainless steel mounts for high precision size "C" sensors, dual enclosure	0WD50	• 10 m (32.8 ft) standard/submersible Coax sensor cable pair with nickel plated brass glands	A5E39669934009
Stainless steel mounts for high precision size "D/E" sensors, dual enclosure	0WD60	• 20 m (65.6 ft) standard/submersible Coax sensor cable pair with nickel plated brass glands	A5E39669934010
Stainless steel bands for high precision mounting enclosures		• 10 m (32.8 ft) standard/submersible Coax sensor cable pair with stainless steel glands	A5E39669934014
Mounting strap for pipe diameter to		• 20 m (65.6 ft) standard/submersible Coax sensor cable pair with stainless steel glands	A5E39669934015
• 300 mm (13")	0SM01	• 20 m (65.6 ft) plenum rated Coax sensor cable pair with Nylon glands	A5E39669934020
• 600 mm (24")	0SM11	• 20 m (65.6 ft) plenum rated Coax sensor cable pair with nickel plated brass glands	A5E39669934025
• 1200 mm (48")	0SM21	• 20 m (65.6 ft) plenum rated Coax sensor cable pair with stainless steel glands	A5E39669934030
• 1500 mm (60")	0SM31		
• 2130 mm (84")	0SM41		
• 3050 mm (120")	0SM51		
• 5486 mm (216")	0SM61		
ADAPTER, MTG STRAP, TEMP COMP	CQO-1012WSM-A2		
Sensor mounting tracks (aluminum with mounting straps) for pipes < 125 mm (5 inch)			

Ultrasonic flowmeter SITRANS FS230 - Accessories/Spare parts

Selection and Ordering data	Article No.	Selection and Ordering data	Article No.
<i>Spare parts (Miscellaneous)</i>		<i>Spare parts (Miscellaneous)</i>	
SITRANS F S Clamp-on	7ME 3 9 6 0 -	SITRANS F S Clamp-on	7ME 3 9 6 0 -
Cable glands and adapters		Universal sensor test blocks	
Cable gland set M20, nylon	A5E38145321	Test block for size A and B universal sensors	0 TB 1 0
Cable gland set M20, nickel/brass	A5E38145323	Test block for size C and D universal sensors	0 TB 2 0
Cable gland set M20, stainless steel	A5E38145327	Thickness gauge	
Iris glands, set of 2, nickel plated brass	A5E38635890	Stand alone thickness gauge	7ME39510TG20
Iris glands, set of 2, stainless steel	A5E38635986		
M20xNPT adapters, set of 8, brass/nickel	A5E38145635		
M20xNPT adapters, set of 8, brass/nickel, Ex	A5E38309159		
M20xNPT adapters, set of 8, stainless steel	A5E38145643		
RTD temperature sensor cables			
6 m (20 ft) standard RTD cable	0 CR 5 0		
15 m (50 ft) standard RTD cable	0 CR 5 1		
30 m (100 ft) standard RTD cable	0 CR 5 2		
46 m (150 ft) standard RTD cable	0 CR 5 3		
61 m (200 ft) standard RTD cable	0 CR 5 4		
91 m (300 ft) standard RTD cable	0 CR 5 5		
6 m (20 ft) submersible RTD cable	0 CR 5 6		
15 m (50 ft) submersible RTD cable	0 CR 5 7		
30 m (100 ft) submersible RTD cable	0 CR 5 8		
46 m (150 ft) submersible RTD cable	0 CR 5 9		
61 m (200 ft) submersible RTD cable	0 CR 6 0		
91 m (300 ft) submersible RTD cable	0 CR 6 1		
Dedicated cable termination kits for:			
Standard, plenum sensor cable (NEMA 4X and NEMA 7 wall)	0 CT 0 1		
Submersible sensor cable (NEMA 4X and NEMA 7 wall)	0 CT 1 1		
Clamp-on RTD cable termination kit for standard RTD	0 CT 2 1		
Clamp-on RTD cable termination kit for submersible RTD	0 CT 3 1		
Insert RTD cable termination kit	0 CT 4 1		
Termination kit for armored cable	CQO:1012CNFX-TK		
Ultrasonic couplants			
Temporary water based for portable systems: 350 ml (12 oz): -34 ... +38 °C (-30 ... +100 °F)	0 UC 1 0		
Permanent synthetic polymer based: 90 ml (3 oz) -40 ... +190 °C (-40 ... +375 °F)	0 UC 1 0		
Dry coupling pad kit (10 pieces)	0 UC 1 0		
Permanent high temperature fluoroether: 163 ml (5.5 oz): -40 ... +230 °C (-40 ... +450 °F)	0 UC 1 0		
Permanent vulcanizing silicone rubber cou- plant: 90 ml (3 oz): -40...+120C (-40...+250F)	CQO:CC112		
Permanent high temperature silicone grease: 12 ml (0.4 oz): -40 ... +230 °C (-40 ... +450 °F)	CQO:CC117B		
Permanent high temperature silicone grease: 150 ml (5 oz): -40 ... +230 °C (-40 ... +450 °F)	CQO:CC117A		
Couplant for submersible sensor applications	CQO:CC120		
Pipe damping films			
B1, B2, B3, C1 and C2 sensors	0 DM 1 0		
D1 and D3 sensors	0 DM 2 0		
D2 sensor	0 DM 3 0		
D4 sensor	0 DM 4 0		

Flow Measurement

SITRANS F S Clamp-on

Ultrasonic flowmeter SITRANS FS220

Overview



The SITRANS FS220 is a clamp-on ultrasonic flow system consisting of an FST020 transmitter and FSS200 clamp-on sensors.

The transmitter classification FST020 describes a basic clamp-on ultrasonic flowmeter for basic application requirements. Based on the same digitalized platform as the FST030 this system provides the same accuracy and similar functions on a lower cost level. This system is ideal for water measurement and any application not requiring temperature or viscosity compensation.

Benefits

- Easy installation at any time; no production stop, no need to cut pipe or stop flow
- Minimal maintenance; external sensors do not require periodic cleaning
- No moving parts to foul or wear. No contact with media
- No pressure drop or energy loss
- Wide turn-down ratio, bidirectional and high stability at zero flow conditions
- Anomaly compensation tool for correction of non-ideal straight pipe runs. Automatic compensation during backflow
- Optional WideBeam technology ensures highest performance and accuracy
- Compatible with all previously installed transit time sensors

Applications

The SITRANS FS220 can be used for the following application conditions:

- Pipe sizes from 10 mm to 10 m
- Pipe materials: ideal for all metals, glass, FRP and most PVC variants; NOT for concrete pipes and special compound pipes
- Pipe wall thickness from 1 to 35 mm; specials on request up to 65 mm
- Media temperatures from -40 to 121 °C; universal high temperature sensors for up to 230 °C max.
- Underground/submerged locations, non-ideal environments, strong pipe vibrations

SITRANS FS220 flowmeters are suitable for most clean liquid applications, including the following:

- Water and wastewater industry
 - Potable water
 - Water and aqueous solutions
 - Wastewater, influent & effluent
 - Processed sewage, sludge
- Chemical feed industry
 - Sodium hypochlorite
 - Sodium hydroxide
- HVAC and power industries
 - Coolant flow
 - Fuel flow
 - Utility district heating, cooling
 - Refrigeration liquids
- Process control
 - Chemicals
 - Pharmaceuticals
 - Food products
 - Very low flow sensitivity (< 0.1 m/s)
 - High temperature liquids > 120 °C (248 °F).

Function

Operating Principle

The SITRANS F S system is a transit-time ultrasonic meter that provides exceptional performance using a non-intrusive clamp-on approach. Ultrasonic sensors transmit and receive acoustic signals directly through the existing pipe wall, where the fluid refraction angle is governed by Snell's law of refraction.

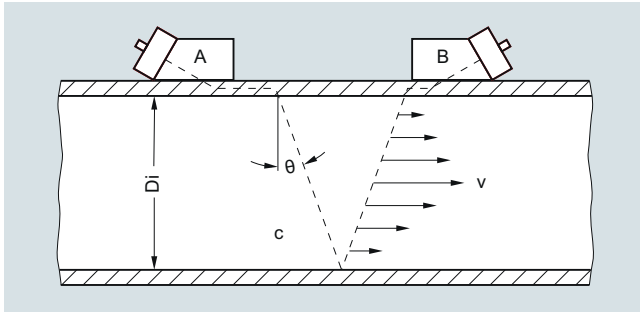

Clamp-on sensor mounted in a reflect configuration

The beam refraction angle is calculated as follows:

$$\sin\theta = c / V_{\phi}$$

c = Velocity of sound in fluid

V_{ϕ} = Phase velocity (a constant in the pipe wall)

The flowmeter automatically compensates for any change in fluid sound velocity (or beam angle) in response to variations in the average transit time between sensors A and B. By subtracting the computed fixed times (within the sensors and pipe wall) from the measured average transit time, the meter can then infer the required transit time in the fluid (T_{Fluid}).

The sound waves traveling in the same direction as the flow ($T_{A,B}$) arrive earlier than sound waves traveling against the direction of flow ($T_{B,A}$). This time difference (Δt) is used to compute the line integrated flow velocity (v) as shown in the equation below:

$$v = V_{\phi} / 2 \cdot \Delta t / T_{\text{Fluid}}$$

Once the raw flow velocity is determined, the fluid Reynolds Number (Re) must be determined to properly correct for fully developed flow profile. This requires the entry of the fluid's kinematic viscosity ($visc$) as shown in the equations below, where Q represents the final flow profile compensated volumetric flow rate.

$$Re = D_i \cdot v / visc \cdot Q = K(Re) \cdot (\pi / 4 \cdot D_i^2) \cdot v$$

v = Flow velocity

$visc = \mu / \rho$ = (dynamic viscosity / density)

$K(Re)$ = Reynolds flow profile compensation

In wetted type ultrasonic flowmeters the meter constants are configured prior to leaving the factory. As this is not possible with clamp-on meters, the settings must be made by the customer at the time of installation. These settings include pipe diameter, wall thickness, liquid viscosity, etc.

SITRANS clamp-on flowmeters that include temperature sensing can be configured to dynamically infer changes in fluid viscosity for the purpose of computing the most accurate flow profile compensation (K_{Re}).

Ultrasonic sensor types

Two basic types of clamp-on sensors can be selected for use with the SITRANS F S flowmeter. The lower cost "universal" sensor is the most common type in the industry and is suitable for most single liquid applications where the sound velocity does not vary much. This sensor type can be used on any sonically conductive pipe material (including steel) making it well suited for temporary survey applications. Universal sensors are selected based on the pipe diameter range alone, so wall thickness is less important to the selection process.

The second sensor type is the "WideBeam" sensor (called high precision), which utilizes the pipe wall as a kind of waveguide to optimize the signal to noise ratio and provide a wider area of vibration. This makes this kind of sensor less sensitive to any change in the fluid medium.

The WideBeam sensor is designed for steel pipes, but can also be used with aluminum, titanium and plastic pipe. It is the preferred sensor for HPI and gas applications. Note that unlike the universal type, this sensor selection is dependent only on the pipe's wall thickness.

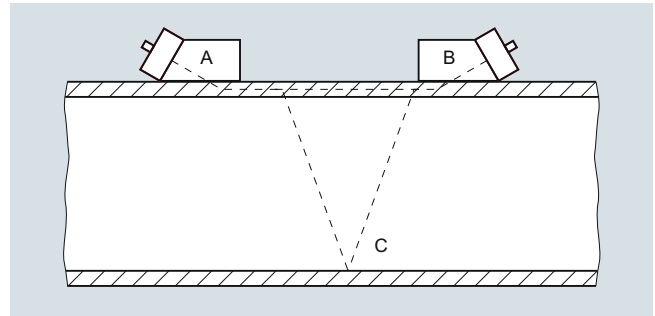

General installation guidelines for SITRANS FSS200 clamp-on sensors

- Minimum measuring range: 0 to ± 0.3 m/s velocity (see meter accuracy graph on next page for more detail)
- Maximum measuring range: 0 to ± 12 m/s (± 30 m/s for high precision sensors). Final flow range determination requires application review

Flow Measurement

SITRANS F S Clamp-on

Ultrasonic flow sensor SITRANS FSS200

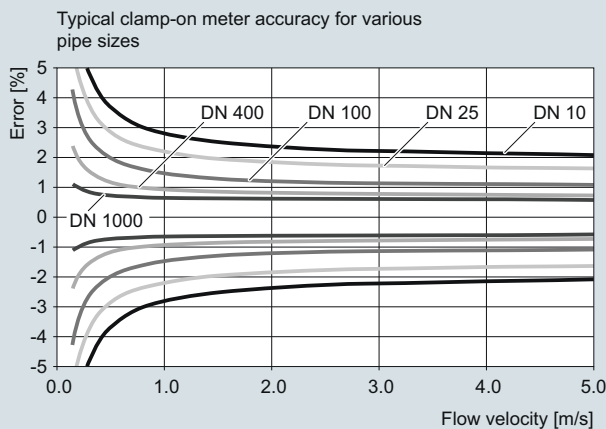

- Pipe must be completely full within the sensor installation volume for accurate flow measurement
- Typical MINIMUM straight pipe requirements are: 10 Diameters upstream/5 Diameters downstream. Additional straight run is required for double out-of-plane elbows and partially open valves.
- Sensors should be installed at least 20° off vertical for horizontal pipes. This reduces the chance of beam interference from gas buildup at the top of the pipe
- Operation inside the Reynolds transition region, between $1000 < Re < 5000$ should be avoided for best accuracy
- Submersible and direct burial installations can be accommodated. Consult sales representative for details
- Ultrasonic coupling compound is provided with all sensor orders. Insure that a permanent coupling compound is used for long term installations
- Refer to the "Sensor type selection guide" to insure proper application of the equipment

Sensor type selection guide



Standard sensor supported in MLFB

Application condition	High precision	Universal	Notes
Note all that apply before making selection.			
Media			
General survey (clean liquids) on non-steel pipes		X	
General survey (clean liquids) on a limited range of steel pipes	X		
Moderately aerated liquid or slurry, up to 121 °C (250 °F)	X		
Permanent installation on steel pipe (clean liquids)	X		
Installation in offshore or corrosive environment	X		With optional stainless steel mounting
Liquid temperature greater than 120 °C (248 °F)	O	X	High temperature metal block sensors available to 230 °C (446 °F)
Operation on single pipeline flowing multiple products	X	O	
Pipe material			
Steel	X		
Steel pipe with diameter/wall thickness ratio <10	O	X	
Non-steel pipe material (copper, ductile iron, cast iron, etc.)	O	X	High precision sensors can also be used on plastic and aluminum pipes in special cases

O = not suitable X = preferred choice

Definitions

Sensor chart	Description
FSS200	Formerly 1011 clamp-on sensors of the 1010 systems
Standard	Standard system sensor, selectable as part of a configured product
Special	Sensors available for non-standard applications and pipes. Contact tech support for application use
Corrosion resistant	Stainless steel metal parts on all Size C, D and E and all high temperature sensors
Aluminum	Aluminum metal parts on all HP and Universal size A and B (Corrosion resistant on request for size B)
Spare	Not available as part of a configured product, must be ordered separately
CE	Transmitter and sensors certified for sale in the EU
Trackless mount	Sensors fixed only by straps, no other mounting (spacer bar as an option) - not recommended
Tracks	Permanent installation for universal size A/B, high precision size A/B and all sizes of high temperature. Tracks always come as dual-part for either direct or reflect mounting, and always with straps.
Frames	Three sizes, for permanent installation for universal size C/ D/ E, and for high precision size C/D. For universal and high precision size B available for pipes > 125 OD (Spare)
T1	Usable from -40 ... +120 °C (-40 ... +248 °F), but best for Ø temperature below 80 °C (< 176 °F), standard
T2	Usable from -40 ... +120 °C (-40 ... +248 °F), but best for Ø temperature above 80 °C (> 176 °F)
Submersible	Sensors can be used submerged; adding Denso for supplemental protection is recommended

Flow Measurement

SITRANS F S Clamp-on

Ultrasonic flow sensor SITRANS FSS200

Sensor availability guide

Sensor models	Availability									
	Standard	Spare only	Corrosion resistant	Trackless	Tracks	Frames	T1 best use below 80 °C (176 °F)	T2 best use 80 ... 120 °C (176 ... 248 °F)	Submersible	Catalog
Universal Sensor -40 ... 120 °C (-40 ... +248 °F) housing CE IP68										
A1 Universal for pipe OD – 5.8 ... 50.8 mm (0.23" ... 2")		X			X				X	
A2 Universal for pipe OD – 12.7 ... 50.8 mm (0.5" ... 2")	X				X				X	X
B1 Universal for pipe OD – 12.7 ... 76 mm (0.5" ... 3")		X			X	X			X	
B2 Universal for pipe OD – 12.7 ... 76 mm (0.5" ... 3")		X			X	X			X	
B3 Universal for pipe OD – 19 ... 127 mm (0.75" ... 5")	X				X	X			X	X
C1 Universal for pipe OD – 51 ... 254 mm (2" ... 10")		X	X	X		X			X	
C2 Universal for pipe OD – 51 ... 254 mm (2" ... 10")		X	X	X		X			X	
C3 Universal for pipe OD – 51 ... 305 mm (2" ... 12")	X		X	X		X			X	X
D1 Universal for pipe OD – 102 ... 508 mm (4" ... 20")		X	X	X		X			X	
D2 Universal for pipe OD – 152 ... 610 mm (6" ... 24")		X	X	X		X			X	
D3 Universal for pipe OD – 203 ... 610 mm (8" ... 24")	X		X	X		X			X	X
E1 Universal for pipe OD – 254 ... 3048 mm (10" ... 120")		X	X	X		X			X	
E2 Universal for pipe OD – 254 ... 6096 mm (10" ... 240")	X		X	X		X			X	X
E3 Universal for pipe OD – 304 ... 9144 mm (12" ... 360")		X	X	X		X			X	
High Precision Sensor -40 ... +120 °C (-40 ... +248 °F) T1 (T2) CE IP68										
A1H (High Precision) for pipe WT - 0.64 ... 1.0 mm (0.025" ... 0.04")		X				X	X		X	X
A2H (High Precision) for pipe WT - 1.0 ... 1.5 mm (0.04" ... 0.06")	X					X	X		X	X
A3H (High Precision) for pipe WT - 1.5 ... 2.0 mm (0.06" ... 0.08")	X					X	X		X	X
B1H (High Precision) for pipe WT - 2.0 ... 3.0 mm (0.08" ... 0.12")	X					X	X	X	X	X
B2H (High Precision) for pipe WT - 3.0 ... 4.1 mm (0.12" ... 0.16")	X					X	X	X	X	X
B3H (High Precision) for pipe WT - 2.7 ... 3.3 mm (0.106" ... 0.128")		X				X	X	X	X	X
C1H (High Precision) for pipe WT - 4.1 ... 5.8 mm (0.16" ... 0.23")	X		X	X		X	X	X	X	X
C2H (High Precision) for pipe WT - 5.8 ... 8.1 mm (0.23" ... 0.32")	X		X	X		X	X	X	X	X
D1H (High Precision) for pipe WT - 8.1 ... 11.2 mm (0.32" ... 0.44")	X		X	X		X	X	X	X	X
D2H (High Precision) for pipe WT - 11.2 ... 15.7 mm (0.44" ... 0.62")	X		X	X		X	X	X	X	X
D3H (High Precision) for pipe WT - 7.4 ... 9.0 mm (0.293" ... 0.354")		X	X	X		X	X	X	X	X
D4H (High Precision) for pipe WT - 15.7 ... 31.8 mm (0.62" ... 1.25")	X		X	X		X	X	X	X	X
High Temperature Universal Sensor -40 ... +230 °C (-40 ... +446 °F)										
High Temperature size 1 ... 230 °C (Ø 12.7 ... 100 mm)		X	X		X					X
High Temperature size 2 ... 230 °C (Ø 30 ... 200 mm)	X		X		X					X
High Temperature size 3 ... 230 °C (Ø 150 ... 610 mm)	X		X		X					X
High Temperature size 4 ... 230 °C (Ø 400 ... 1200 mm)	X		X		X					X
High Temperature size 2A ... 230 °C (Ø 30 ... 200 mm)		X	X		X					
High Temperature size 3A ... 230 °C (Ø 150 ... 610 mm)		X	X		X					
High Temperature size 4A ... 230 °C (Ø 400 ... 1200 mm)		X	X		X					

Sensor mounting availability guide

	Sensor (Dedicated)		
	Universal	High Precision	High Temperature universal
Mounting			
Trackless (straps only)	X	X	
Tracks universal dedicated	X		
Tracks HP dedicated		X	
Frames universal dedicated	X		
Frames HP dedicated		X	
Tracks high temperature universal			X
High precision mount single enclosure for one pair sensors		X	
High precision mount dual enclosure for one pair sensors		X	
Spacer Bar	X	X	
Straps	X	X	X
Denso	X	X	

Flow Measurement

SITRANS F S Clamp-on

Ultrasonic flow transmitter SITRANS FST020

Overview



The SITRANS FST020 is the basic device for simple and cost-effective clamp-on applications. As a single-path device, it is suitable for flow measurement on liquids that do not require temperature or viscosity consideration and where highest accuracies are not required.

Historically, the FST020 comes from the clamp-on family of analog FUS1010 transmitters. Since the revision in 2017, the updated transmitter is now part of a digital platform based on the latest developments within Digital Signal Processing (DSP) technology - engineered for high measuring performance, fast response to step changes in flow, high immunity against process noise and simplicity in installation, commissioning and maintenance.

The FST020 transmitter delivers standard parameter measurements i.e. volume flow, flow speed or sound velocity by analog outputs and Modbus communication.

Process values

- Volume flow
- Flow velocity
- Sound velocity
- Totalizer 1, 2 and 3

Benefits

Flow calculation and measurement

- Dedicated volume flow calculation with DSP technology
- 100 Hz update rate for all primary process values
- Maximum data age from sensor to output is 20 ms
- Independent low flow cut-off settings for volume flow and velocity
- Zero-point adjustment on command from discrete input or host system

Operation and display

- User-configurable operation display
 - Fully graphical display 240 x 160 pixel display with up to 6 programmable views
 - Self-explaining alarm handling/log in clear text
 - Help text for all parameters appears automatically in the configuration menu
- SensorFlash technology stores production specific system documentation and provides removable memory of all flowmeter setups and functions
 - Calibration certificates (with ordered calibration)
 - Non-volatile memory backup of operational data
 - Transfer of user configuration to other flowmeters
 - 4GB SD card for storage and data logging
 - Audit trail of all parameter changes
 - Alarm logging

Alarms and safety

- Advanced diagnosis and service menu enhances troubleshooting and meter validation
- Configurable upper and lower alarm and warning limits for all process values

Outputs and control

- Monitoring comprised of 3 individually configurable totalizers
- Single parameter outputs that can be assigned individually to any of the following parameters:
 - Volume flow
 - Flow velocity
 - Sound velocity
 - Flow direction

Channel 1 is 4 to 20 mA analog output. The current signal can be configured for passive volume flow.

Relay output(s) can be user configured to Alarm status or warning.

Modbus RTU RS 485 comes as standard.

Signal input

The signal input can be user-configured for:

- Totalizer reset functions
- Forcing outputs or freezing process values
- Initiating automatic zero point adjustment

Approvals and certificates

The SITRANS FST020 transmitter was designed to comply with or exceed the requirements of international standards and regulations.

Design

- Field clamp-on (non-intrusive)
- Single path, for only one pair of sensors on one pipe
- IP65 (NEMA 4X) wall mount housing, constructed of polycarbonate
- Available AC or DC power, 100 to 240 V AC, 11.5 to 28.5 V DC

Function

- 240 x 160 pixel graphical display with 4 key navigation and backlight
- 6 user programmable views for individual process and diagnostic information
- Modbus RTU communication
- 100 Hz update rate for all primary process values
- Independent low flow cut-off settings for volume and flow velocity
- Fully compatible with Siemens PDM version 8.2 service pack 1 or higher
- Bidirectional flow operation
- Menus available in English and German

Technical specifications

Rangeability		Accuracy	
Flow range	±12 m/s (±40 ft/s), depending on pipe size higher or lower	For velocities above 0.3 m/s (1 ft/s), ±1.0 % of flow	
Flow direction	bi-directional	Repeatability	± 0.25 % (according to ISO 11631)
Flow sensitivity	0.001 m/s (0.003 ft/s) flow rate independent	Zero Drift	0.1 % of rate; < ±0.001 m/s (±0.003 ft/s)
Digital inputs		Data refresh rate	100 Hz
Totalizer Hold	Optically isolated diode Activated On: Input voltage: 2 ... 10 V DC	Transmitter conditions	
Totalizer Reset	Optically isolated diode Activated On: Input voltage: 2 ... 10 V DC	Operating temperature	-10 ... +50 °C (14 ... 122 °F)
Output Channel 1		Storage temperature	-20 ... +60 °C (-4 ... +140 °F)
Current	4 ... 20 mA (isolated) Externally powered 10 ... 30 V DC	Degree of protection	IP65, NEMA 4X
Relay	30 V DC, 3 V AC max.	Design	
Pulse rate	Optically isolated transistor 10 mA, 30 V DC max. Pulse: 41.6 ms ... 5 s pulse duration Frequency: 0 ... 12.5 kHz (50 % duty cycle)	Weight	1.4 kg (3.0 lb)
		Dimensions (W x H x D)	176 x 240 x 87 mm (6.9 x 9.5 x 3.4 inch)
		Enclosure material	Polycarbonate
		Power supply	
		100 ... 240 V AC @ 20 VA or 11.5 ... 28.5 V DC @ 10 W	
		Certificates and approvals	
		Unclassified locations	
		• General Safety	UL, ULc, CE

Dimensional drawings

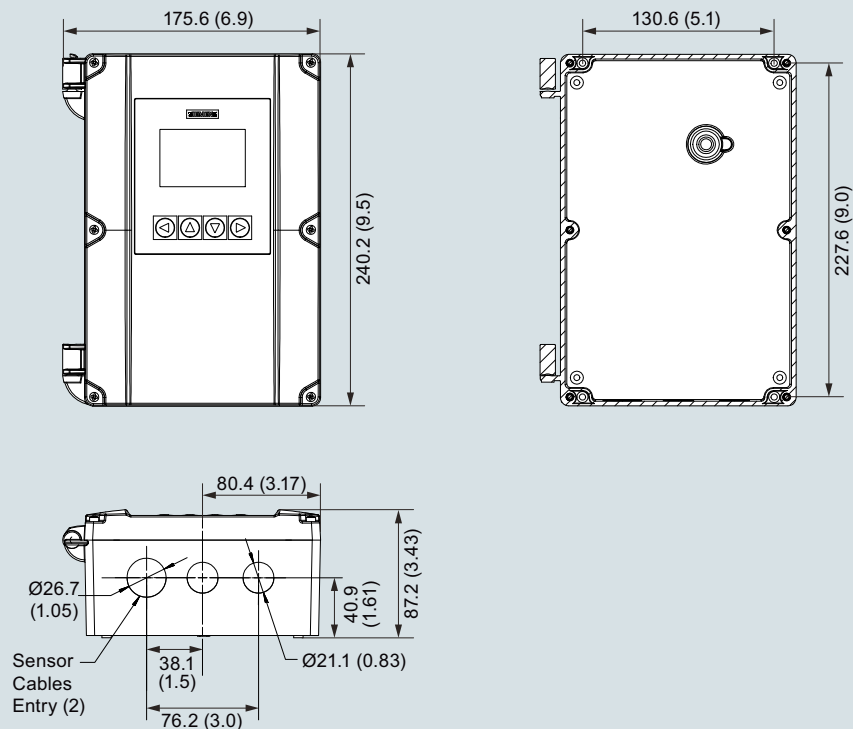

SITRANS FST020 IP65 (NEMA 4X), wall mount enclosure, dimensions in mm (inch)

Flow Measurement

SITRANS F S Clamp-on

Ultrasonic flow transmitter SITRANS FST020, wall mount housing - Ordering data

Selection and Ordering data				Article No.	Ord. code
Transmitter SITRANS FST020 (Basic), IP65 (NEMA 4X)				7ME3570-	40-0
Click on the Article No. for the online configuration in the PIA Life Cycle Portal.					
Number of ultrasonic paths					
Single path				1	
Flowmeter functions and I/O configurations					
With display, keypad, 1x 4 ... 20 mA, 1x relay, 1x pulse/frequency, 2x digital input, Modbus RTU				J	
Power supply					
100 ... 240 V AC				A	
11.5 ... 28.5 V DC				B	
Sensor FSS200¹⁾					
When ordering a flow system, sensors always come automatically with suitable mounting equipment. Smaller sensor sizes A & B come with mounting tracks, while sensor sizes C, D & E are supplied with frames and spacer bars. Straps provided are for the indicated maximum OD listed below. Strap kits are available to accommodate larger pipes (refer to spare part list). Refer to "Sensor Selection Charts" to find the most suitable sensors for specific pipe sizes and wall thicknesses.					
No sensor					A
For the following Universal sensors, temperature range is -40 ... +121 °C (-40 ... +250 °F), FSS200 Universal: select according to outer pipe diameter					
FSS 200 Universal	A2	12.7 ... 50 mm (0.5 ... 2")	Track mount and straps provided up to 75 mm (3")		B
FSS 200 Universal	B3	19 ... 127 mm (0.75 ... 5")	Track mount and straps provided up to 125 mm (5")		C
FSS 200 Universal	C3	51 ... 305 mm (2 ... 12")	Mounting frame, straps and spacer bar provided up to 330 mm (13")		D
FSS 200 Universal	D3	203 ... 610 mm (8 ... 24")	Mounting frame and straps and spacer bar provided up to 600 mm (24")		E
FSS 200 Universal	E2	304 ... 9144 mm (12 ... 360")	Mounting frame and straps and spacer bar provided up to 1200 mm (48")		F
For the following High Precision sensors T1, temperature range is -40 ... +120 °C (-40 ... +248 °F), FSS200 High Precision: select according to pipe wall thickness					
FSS200 HP	A1H	0.6 ... 1.0 mm (0.025 ... 0.4")	Track mount and straps provided up to 75 mm (3")		G
FSS200 HP	A2H	1.0 ... 1.5 mm (0.04 ... 0.06")	Track mount and straps provided up to 75 mm (3")		H
FSS200 HP	A3H	1.5 ... 2.0 mm (0.06 ... 0.08")	Track mount and straps provided up to 75 mm (3")		J
FSS200 HP	B1H	2.0 ... 3.0 mm (0.08 ... 0.12")	Track mount and straps provided up to 125 mm (5")		K
FSS200 HP	B2H	3.0 ... 4.1 mm (0.12 ... 0.16")	Track mount and straps provided up to 125 mm (5")		L
FSS200 HP	C1H	4.1 ... 5.8 mm (0.16 ... 0.23")	Mounting frame, straps and spacer bar provided up to 600 mm (24")		M
FSS200 HP	C2H	5.8 ... 8.1 mm (0.23 ... 0.32")	Mounting frame, straps and spacer bar provided up to 600 mm (24")		N
FSS200 HP	D1H	8.1 ... 11.2 mm (0.32 ... 0.44")	Mounting frame, straps and spacer bar provided up to 1200 mm (48") ¹⁾		P
FSS200 HP	D2H	11.2 ... 15.7 mm (0.44 ... 0.62")	Mounting frame, straps and spacer bar provided up to 1200 mm (48") ¹⁾		Q
FSS200 HP	D4H	15.7 ... 31.8 mm (0.62 ... 1.25")	Mounting frame, straps and spacer bar provided up to 1200 mm (48") ¹⁾		R
For the following High Temperature sensors, temperature range is -40 ... +230 °C (-40 ... +446 °F), FSS200 High Temperature: select according to outer diameter					
FSS200 HT	Size 2	30 ... 200 mm (1 ... 8")	Mounting track and straps provided up to 250 mm (10")	Z	P 1 A
FSS200 HT	Size 3	150 ... 610 mm (6 ... 24")	Mounting track and straps provided up to 650 mm (26")	Z	P 2 A
FSS200 HT	Size 4	400 ... 1200 mm (16 ... 48")	Mounting track and straps provided bar provided up to 1250 mm (50")	Z	P 3 A

Ultrasonic flow transmitter SITRANS FST020, wall mount housing - Ordering data

Selection and Ordering data	Article No.	Ord. code
Transmitter SITRANS FST020 (Basic), IP65 (NEMA 4X)	7ME3570 - 40 - 0	
Sensor cable (pair - terminated)		
No sensor cable		A
Sensor cable, HDPE jacket, submersible, length		P
• 5 m (16.4 ft)		Q
• 10 m (32.8 ft)		R
• 20 m (65.6 ft)		
Approvals		
UL, ULc, CE		1
1) Supplied spacer bar supports pipes up to 1050 mm (42"). For pipes larger than 1050 mm (42") purchase also, spare part 7ME3960-OMS40 (1012BN-4)		
2) Made of stainless steel construction.		

Selection and Ordering data	Order code
Further designs	
Please add "-Z" to Article No. and specify Order code(s).	
Cable termination kit for customer supplied sensor cable pair	
Sensor cable termination for standard and plenum cable	T01
Tag and name plates	
Tag plate, transmitter and sensor	Y19

MLFB example

Application example

A basic clamp-on meter is required for a DN 150 - 168.3 x 4.5 mm (6" schedule 40) carbon steel wastewater line. Meter electronics are to be located in an instrumentation shed with available AC power. 10 m (32 ft) of sensor cable is needed to reach pipe location.

MLFB Article No.: **7ME3570-1JA40-0MQ1**







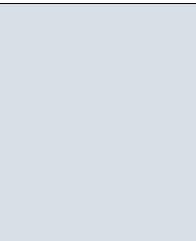
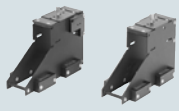

Selection and Ordering data	Article No.	Ord. code
SITRANS FST020 (Basic) IP65 (NEMA 4X)	7ME3570 - 40 - 0	
Single channel		1
Standard I/O option		J
100 ... 240 V AC power option		A
Sensor FSS200 HP C1H		M
Sensor cable: HDPE jacket, submersible, length 10 m (32 ft)		Q
UL, ULc, CE		1

Flow Measurement



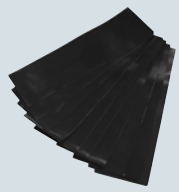

SITRANS F S Clamp-on

Ultrasonic flowmeter SITRANS FS220 - Accessories/Spare parts

Accessories/Spare parts for clamp-on ultrasonic flowmeters

Description	Article No.		Description	Article No.	
FSS200 Universal Sensors Selected for general purpose measurement. Since they are selected based on diameter only, a wide range of pipe sizes and materials can be covered with a minimum number of sensors. These can also be selected for cost savings on applications where standard accuracy is sufficient.	7ME3950-...		Magnetic mounting frames Magnetic mounting frames are designed to simplify clamp-on sensor installation on pipelines 8 inches (DN 200) and larger by eliminating the need for straps to secure them. They feature powerful magnets to ensure quick and accurate setup. Compatible with all C, D and E universal and high-precision sensors belonging to the SITRANS FSS200 clamp-on family. Magnetic mounting frames are constructed in aluminum for a high level of durability. Ideal use on temporary installations.	7ME3960-0MD02	
FSS200 High Precision Sensors Selected for increased performance on steel pipes. They provide the highest accuracy achievable by the meters and therefore should be selected whenever higher accuracy / repeatability is required primarily based on pipe wall thickness.	7ME3950-...		Test Block Used for checking operation of a meter and sensors prior to a field installation, or as a troubleshooting tool. Selected by sensor size, each block accommodates 2 sensor sizes. Available only for universal sensors.	7ME3960-...	
FSS200 High Temperature Sensors Selected whenever pipe temperature will exceed 250 °F (120 °C) up to a maximum of 450 °F (232 °C). They are universal type and can therefore be used on any pipe material and are selected by pipe diameter. Constructed in stainless steel. Connection junction box included.	7ME3950-...		Straps Used to fasten sensors or mounting frames to pipe for dedicated meter installations. Stainless steel construction for corrosion resistance.	7ME3960-...	
Mounting tracks Typically used on smaller pipes for easier and more stable mounting of dedicated universal style sensor size A or B; also available for dedicated high precision sensor size A or B.	7ME3960-...		Cable Gland Kit Cable gland kit for use with SITRANS FST020 transmitters housed in IP65 NEMA 4X wall mount enclosures. Kit contains two single port glands for power and one dual port gland for sensor cables.	A5E41693895	
Mounting Frames These items are useful in simplifying sensor installation. They are strapped to the pipe first and then the sensors are installed, making the installation less cumbersome and more precise. They also enable easy repeated mounting of the sensors assuring alignment to the original sensor positioning. They may be left in place at each measurement location where periodic flow surveys are conducted to simplify subsequent installations and ensure repeatable results.	7ME3960-...		Ultrasonic Couplant Fills any voids between sensor emitting surface and pipe wall to allow maximum energy transfer between sensor and pipe. Several different types of couplants are employed as determined by the application conditions and type of installation (Temporary or permanent).	7ME3960-...	
			Dry Couplant The dry coupling pad is intended for use in any liquid, clamp-on transit time or Doppler applications that require a more durable coupling material. Installation is easy by simply placing one strip of material between sensor and pipe. Not intended for clamp-on gas where damping material is used. The temperature range is -34 to +200 °C (-30 to +392 °F).	7ME3960-...	

Ultrasonic flowmeter SITRANS FS220 - Ordering data

Description	Article No.	
Termination Kit (Flow Sensors) Termination kit for one pair of sensor cables. These can be provided in cases where users will be purchasing bulk cable directly and cutting to length at site, or when existing cable length is to be altered. Selected by cable type.	7ME3960-...	
FST020 Transmitter module Main transmitter module for FST020 including SD-card and firmware load	A5E41693884	
FST020 Transmitter module cover AC Cover for FST020 Main transmitter module for AC powered units; includes label and screws	A5E41693888	
FST020 Transmitter module cover DC Cover for FST020 Main transmitter module for DC powered units; includes label and screws	A5E41693889	
FST020 Enclosure cover Enclosure lid for FST020; includes display module, connection label and screws	A5E38846901	
FST020 Power Supply AC Power supply module for FST020, AC power	7ML1830-1MD	
FST020 Power Supply DC Power supply module for FST020, DC power	7ML1830-1ME	
SensorFlash SD-card 4 GB micro SD card -40 °C ... +85 °C for FST020 or FST030 for data storage, firmware and back-up	A5E38288507	
Hardware kit Various nuts, screws, and grounding strap for FST020 transmitter	A5E41944763	
Sensor cable pair, 5 m Sensor cable for connection between FSS200 sensors and FST020 transmitter, 5 meters in length	A5E39669934 031	
Sensor cable pair, 10 m Sensor cable for connection between FSS200 sensors and FST020 transmitter, 10 meters in length	A5E39669934 032	

Description	Article No.	
Sensor cable pair, 20 m Sensor cable for connection between FSS200 sensors and FST020 transmitter, 20 meters in length	A5E39669934 033	
Enclosure mounting kit Mounting kit to fix enclosure on a 2" stanchion pipe	QCB: 1012NMB-1	

Flow Measurement

SITRANS F S Clamp-on

Ultrasonic flowmeter SITRANS FS220 - Ordering data

Selection and Ordering data	Article No.	Selection and Ordering data	Article No.
<i>Spare parts (FSS200 sensors)</i>		<i>Spare parts (Miscellaneous)</i>	
SITRANS F US clamp-on	7ME3950-5	SITRANS F US clamp-on	7ME3960-
Temperature range for all sensors is unless otherwise noted -40 °C ... +120 °C (-40 °F ... +248 °F)		↗ Click on the Article No. for the online configuration in the PIA Life Cycle Portal.	
Ideal operating temperatures as follows:		Dedicated sensor mounting hardware	
T1: -40 ... +80 °C (-40 ... +176 °F)	0	Sensor mounting tracks (dual part aluminum with mounting straps) for pipes < 125 mm (5 inch)	
T2: 80 ... 121 °C (176 ... 250 °F)	2	<ul style="list-style-type: none"> Tracks for Universal sensor pair size A or B 	0MA00
Spare sensor code (Stainless steel construction)		<ul style="list-style-type: none"> Tracks for High precision sensor pair size A or B 	0MB00
<u>Liquid flow sensors for use with mounting frames or tracks</u>		Sensor mounting frames pair with mounting straps	
FSS200 A2 universal	LB01	<ul style="list-style-type: none"> Frames for Universal sensor size B (for pipes > 125 mm (5 inch)) 	CQO:1012FN-PB
FSS200 B3 universal	LC01	<ul style="list-style-type: none"> Frames for Universal sensor size C 	0MC00
FSS200 C3 universal	LD00	<ul style="list-style-type: none"> Frames for Universal sensor size D 	0MC01
FSS200 D3 universal	LE00	<ul style="list-style-type: none"> Frames for Universal sensor size E 	0MC02
FSS200 E2 universal	LF00	<ul style="list-style-type: none"> Frames for High precision sensor size B (for pipes > 125 mm (5 inch)) 	CQO:1012FNH-PB
FSS200 A1H (high precision)	LG01	<ul style="list-style-type: none"> Frames for High precision sensor size C 	0MD00
FSS200 A2H (high precision)	LH01	<ul style="list-style-type: none"> Frames for High precision sensor size D 	0MD01
FSS200 A3H (high precision)	LJ01	Mounting straps for mounting frames (slotted stainless steel)	
FSS200 B1H (high precision)	GK1	<ul style="list-style-type: none"> Straps for pipes from DN 50 to DN 150 	0SM00
FSS200 B2H (high precision)	GL1	<ul style="list-style-type: none"> Straps for pipes from DN 50 to DN 300 	0SM10
FSS200 B3H (high precision)	GT1	<ul style="list-style-type: none"> Straps for pipes from DN 300 to DN 600 	0SM20
FSS200 C1H (high precision)	GM0	<ul style="list-style-type: none"> Straps for pipes from DN 600 to DN 1200 	0SM30
FSS200 C2H (high precision)	GN0	<ul style="list-style-type: none"> Straps for pipes from DN 1200 to DN 1500 	0SM40
FSS200 D1H (high precision)	GP0	<ul style="list-style-type: none"> Straps for pipes from DN 1500 to DN 2100 	0SM50
FSS200 D2H (high precision)	GQ0	<ul style="list-style-type: none"> Straps for pipes from DN 2100 to DN 3000 	0SM60
FSS200 D3H (high precision)	GU0	Spacer bars (for indexing sensors on pipe)	
FSS200 D4H (high precision)	GR0	<ul style="list-style-type: none"> Spacer bar for pipes to 200 mm/8 inch (liquid), 600 mm/24 inch (gas) 	0MS10
<u>High temperature universal liquid sensors up to 230 °C (446 °F)</u>		<ul style="list-style-type: none"> Spacer bar for pipes to 500 mm/20 inch (liquid), DN 1200/48 inch (gas) 	0MS20
FSS200 High temp. sensor size 1 for 12.7 to 100 mm diam.	LA13	<ul style="list-style-type: none"> Spacer bar for pipes to 800 mm/32 inch (liquid) 	0MS30
FSS200 High temp. sensor size 2 for 30 to 200 mm diam.	LA23	<ul style="list-style-type: none"> Spacer bar-extension for pipes to 1200 mm/ 48 inch (liquid) Only use in conjunction with 7ME3960-0MS30 	0MS40
FSS200 High temp. sensor size 3 for 150 to 600 mm diam.	LA43	High precision mounting enclosures. Spacer bar is included; straps should be ordered separately	
FSS200 High temp. sensor size 4 for 400 to 1200 mm diam.	LA73	<ul style="list-style-type: none"> Stainless steel mounts for high precision size "C" sensor pair, single enclosure (each) 	0WS50
		<ul style="list-style-type: none"> Stainless steel mounts for high precision size "D/E" sensor pair, single enclosure (each) 	0WS60
		<ul style="list-style-type: none"> Stainless steel mounts for high precision size "C" sensor pair, dual enclosure (pair) 	0WD50
		<ul style="list-style-type: none"> Stainless steel mounts for high precision size "D/E" sensor pair, dual enclosure (pair) 	0WD60

Selection and Ordering data	Article No.
<i>Spare parts (Miscellaneous)</i>	
SITRANS F US clamp-on	7ME3960 -
Stainless steel straps for weld seal enclosure mounting (2 x required for dual enclosures)	
Mounting strap for pipe diameter to 300 mm (13 inch)	0 SM 0 1
Mounting strap for pipe diameter to 600 mm (24 inch)	0 SM 1 1
Mounting strap for pipe diameter to 1200 mm (48 inch)	0 SM 2 1
Mounting strap for pipe diameter to 1500 mm (60 inch)	0 SM 3 1
Mounting strap for pipe diameter to 2130 mm (84 inch)	0 SM 4 1
Mounting strap for pipe diameter to 3050 mm (120 inch)	0 SM 5 1
Stainless mounting tracks for High temp. 991 sensors, with straps, dual part for direct and reflect mount, incl. straps	
Size 1 high temp sensor pair	CQO:992MTNHMSH-1
Size 2 high temp sensor pair	CQO:992MTNHMSH-2
Size 3 high temp sensor pair	CQO:992MTNHMSH-3
Size 4 high temp sensor pair	CQO:992MTNHMSH-4
Sensor cables FSS220 (IP65 NEMA 4X) wall mount	
Sensor cable pair, terminated, 5 m	A5E39669934031
Sensor cable pair, terminated, 10 m	A5E39669934032
Sensor cable pair, terminated, 20 m	A5E39669934033
Dedicated cable termination kits	
For externally supplied sensor cables, standard and plenum	0 CT 0 1
Cable gland kit (normally supplied with transmitter) for IP65 NEMA 4X enclosures	
	A5E41693895
Ultrasonic couplant	
Temporary water based for portable systems: 350 ml (12 oz): -34 ... +38 °C (-30 ... +100 °F)	0 UC 1 0
Permanent synthetic polymer based: 90 ml (3 oz) -40 ... +190 °C (-40 ... +375 °F)	0 UC 2 0
Permanent high temp fluoroether: -40 ... +230 °C (-40 ... +450 °F)	0 UC 3 0
Permanent vulcanizing silicone rubber couplant: 90 ml (3 oz): -40 ... +120 °C (-40 ... +250 °F)	CQO:CC112
Permanent high temp silicone grease: 12 ml (0.4 oz): -40 ... +230 °C (-40 ... +450 °F)	CQO:CC117
Permanent high temp silicone grease: 150 ml (5 oz): -40 ... +230 °C (-40 ... +450 °F)	CQO:CC117A
Couplant for submersible sensor applications	CQO:CC120
Dry coupling pads (qty of 10): -34 to +200 °C (-30 to +392 °F)	0 UC 4 0
Universal Sensor Test Blocks	
Test block for size A and B universal sensors	0 TB 1 0
Test block for size C and D universal sensors	0 TB 2 0

Flow Measurement

SITRANS F US Clamp-on

Thickness gauge

Overview



The thickness gauge is used to measure the wall thickness of the pipe that a clamp-on ultrasonic flowmeter is installed on. The wall thickness value is a vital factor in the flow computation model and a prerequisite for precise clamp-on ultrasonic flow measurement. When measuring any pipe wall thickness the thickness gauge can also be used as a stand-alone tool used to measure the wall thickness of any metallic or non-metallic pipe materials capable of acting as an ultrasonic wave conductor.

Benefits

The thickness gauge is an indispensable tool in accurate clamp-on ultrasonic flow measurement. For a flowmeter to measure correctly it needs to know the exact wall thickness of the pipe it is measuring on. Since even the smallest miscalculation can have a major effect on the flow reading, the pipe thickness gauge has to be extremely precise. This is why the standard probe operates at a 5 MHz frequency making it capable of measuring pipe thickness ranging from 0.1 to 200 mm (0.03" to 7.9") with a very high resolution of up to 0.1 mm (0.004").

Application

The thickness gauge can be used in any field application where there is a need for flow measurement.

Design

The hand-held micro-processor controlled gauge is designed to measure the thickness of various metallic or non-metallic pipe. Such materials include steel, aluminum, titanium, plastics and ceramics. Measurement results are shown in either inches or millimeter; only a simple pre-calibration to a known thickness or sound velocity is required. The simple-to-read 4-digit LCD display featuring a basic user friendly menu is easily navigable with only three conveniently located push buttons. The lightweight computing unit weighs a mere 150 g (5.3 oz) making it ideal for quick and easy on-site pipe wall thickness measurement and with two AAA alkaline batteries trouble-free operation is ensured for 250 hours.

Function

The thickness gauge measurement is based on the transit time ultrasonic wave propagation principle: a high frequency ultrasonic beam is transmitted into the pipe being measured through a probe acting as a sender and receiver. When the probe subsequently retrieves that same signal, an internal counter calculates the time taken for the signals to be sent and received through the pipe. This value is used to evaluate the speed of sound through the pipe and consequently, the thickness of the pipe wall.

Technical specifications

Display type	4-digit LCD
Display resolution	0.1 mm (0.004")
Measurement units	Metric and imperial
Sound velocity range	1 000 ... 9 999 m/s (3 280 ... 32 805 ft/s)
Operating temperature	-10 ... +50 °C (14 ... 122 °F)
Probe/pipe temperature	70 °C (158 °F)
Update rate	4 Hz
Frequency	5 MHz
Power source	2 x 1.5 V AAA dry cells
Power consumption	Working current is less than 3 mA
Battery life	Approx. 250 h on a set of batteries
Dimensions (W x H x D)	61 x 108 x 28 mm (2.4 x 4.3 x 1.1")
Weight	150 g (5.3 oz)

Selection and Ordering data

Article No.

Thickness gauge

7ME3951-0TG20